

A-Series

1 to 10 volts/1000 rpm



B-Series

11 to 24 volts/1000 rpm



A-Series

Instrument Type:

- 0.120 inch shaft diameter
- Small in size
- Ideally suited to instrumentation applications

Industrial Type:

- 0.187 inch shaft diameter
- Special front-end bearings for radial loads
- Ideal for pulley and belt drive applications

B-Series

As is the case with the A-Series generators, the B-Series also comes in instrument and industrial configurations. The output voltage ranges between 11 and 24 v/1000 rpm, depending on the unit. Electrical characteristics, ripple, linearity and temperature effects, etc., are the same as the A-Series.

Other shaft sizes and mounting configurations are available.

A-Series and B-Series Specifications

| Model Number | Mounting | Weight (Approx) | Inertia (Approx) oz-in-sec ² | V/1000 rpm | RPM (max) | Arm Resistance (ohms dynamic) | Armature Inductance (henrys) | Outline Dimensions | Mounting Dimensions | Shaft Size (inches) |
|--------------|----------|-----------------|---|------------|-----------|-------------------------------|------------------------------|--------------------|---------------------|---------------------|
| SA-740A-7 | Face | 3.0 oz | 1.32 x 10 ⁻⁴ | 2.6v | 12,000 | 40Ω | 0.024h | Fig. 10 | Fig. 1 | .120 |
| SB-740A-7 | Flange | 3.0 oz | 1.32 x 10 ⁻⁴ | 2.6v | 12,000 | 40Ω | 0.024h | Fig. 10 | Fig. 2 | .120 |
| SA-740A-2 | Face | 3.0 oz | 1.32 x 10 ⁻⁴ | 7.0v | 12,000 | 350Ω | 0.18h | Fig. 10 | Fig. 1 | .120 |
| SB-740A-2 | Flange | 3.0 oz | 1.32 x 10 ⁻⁴ | 7.0v | 12,000 | 350Ω | 0.18h | Fig. 10 | Fig. 2 | .120 |
| SA-757A-2 | Face | 3.0 oz | 1.32 x 10 ⁻⁴ | 7.0v | 12,000 | 350Ω | 0.18h | Fig. 11 | Fig. 1 | .187 |
| SB-757A-2 | Flange | 3.0 oz | 1.32 x 10 ⁻⁴ | 7.0v | 12,000 | 350Ω | 0.18h | Fig. 11 | Fig. 2 | .187 |
| SA-740B-1 | Face | 4.0 oz | 2.27 x 10 ⁻⁴ | 20.8v | 8,000 | 1000Ω | 0.56h | Fig. 10 | Fig. 1 | .120 |
| SB-740B-1 | Flange | 4.0 oz | 2.27 x 10 ⁻⁴ | 20.8v | 8,000 | 1000Ω | 0.56h | Fig. 10 | Fig. 2 | .120 |
| SA-757B-1 | Face | 4.0 oz | 2.27 x 10 ⁻⁴ | 20.8v | 8,000 | 1000Ω | 0.56h | Fig. 11 | Fig. 1 | .187 |
| SB-757B-1 | Flange | 4.0 oz | 2.27 x 10 ⁻⁴ | 20.8v | 8,000 | 1000Ω | 0.56h | Fig. 11 | Fig. 2 | .187 |

Maximum Driving Torque for A and B series is 0.25 oz-in

Most units listed above are normally in stock

Mounting and Outline Dimensions

Figure 1 SA Face Mount

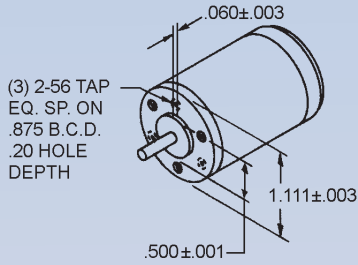

Figure 2 SB Flange Mount

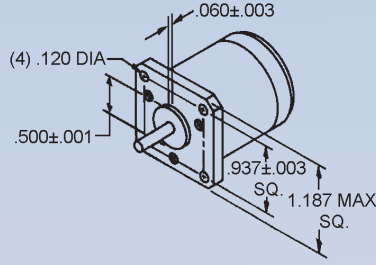

Figure 3 SD Modified Synchro

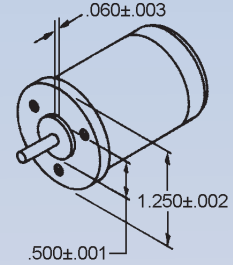

Figure 4 SM Aircraft Mount

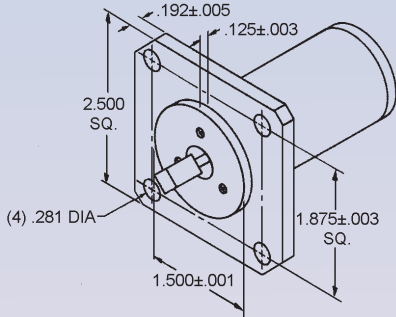

Figure 5 SU Large Flange Mount

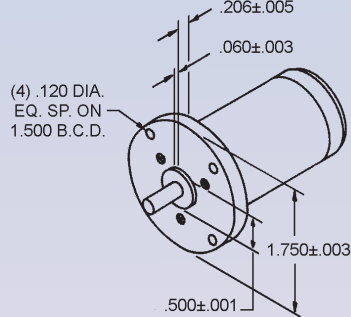

Figure 6 SS Synchro Mount

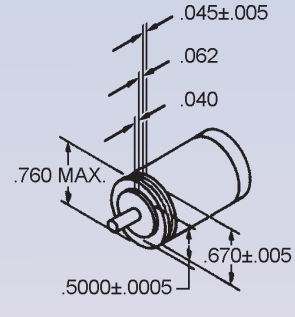
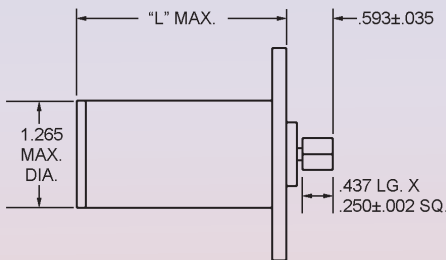
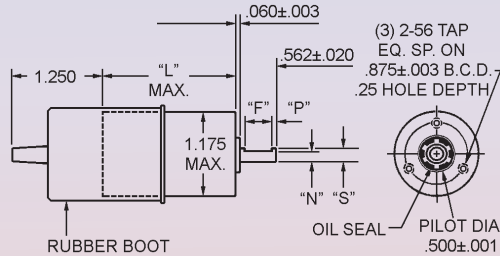

Figure 7 Aircraft Configuration



| Model # | "L" |
|---------|-------|
| SM-762A | 2.520 |
| SM-762B | 2.957 |

Figure 8 Sealed Configuration



| Model | "L" | "F" | "P" | "N" | "S" |
|----------|-------|-------|-------|-------|--------------|
| ST-7336A | 1.867 | OMIT | OMIT | OMIT | 0.120 ± .001 |
| ST-7336B | 2.304 | OMIT | OMIT | OMIT | 0.120 ± .001 |
| ST-7337A | 1.875 | 0.375 | 0.062 | 0.157 | 0.187 ± .001 |
| ST-7337B | 2.312 | 0.375 | 0.062 | 0.157 | 0.187 ± .001 |

Figure 9 Flat Shaft Configuration

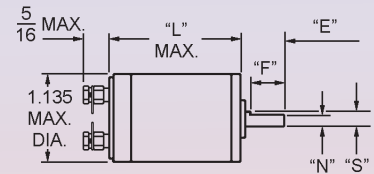

| Model | "L" | "E" | "F" | "N" | "S" |
|----------|-------|-------|-------|-------|--------------|
| XX-7114B | 2.193 | 0.562 | 0.437 | 0.157 | 0.187 ± .001 |
| XX-7114D | 3.253 | 0.562 | 0.437 | 0.157 | 0.187 ± .001 |
| XX-7146A | 1.701 | 0.562 | 0.437 | 0.110 | 0.120 ± .001 |

Figure 10 Instrument/Industrial Configuration

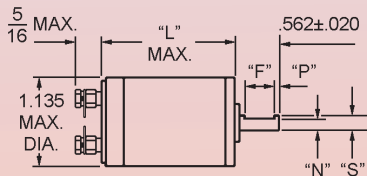

| Model # | "L" | "F" | "P" | "N" | "S" |
|----------|-------|-------|-------|-------|--------------|
| XX-740A | 1.701 | OMIT | OMIT | OMIT | 0.120 ± .001 |
| XX-740B | 2.138 | OMIT | OMIT | OMIT | 0.120 ± .001 |
| XX-780B | 2.193 | 0.375 | 0.062 | 0.157 | 0.187 ± .001 |
| XX-780D | 3.253 | 0.375 | 0.062 | 0.157 | 0.187 ± .001 |
| XX-797A | 1.701 | 0.187 | 0.187 | 0.110 | 0.120 ± .001 |
| XX-7103A | 1.756 | 0.375 | 0.062 | 0.157 | 0.187 ± .001 |
| XX-7107D | 3.253 | OMIT | OMIT | OMIT | 0.187 ± .001 |
| XX-7123A | 1.756 | OMIT | OMIT | OMIT | 0.187 ± .001 |
| XX-7123B | 2.193 | OMIT | OMIT | OMIT | 0.187 ± .001 |
| XX-7356F | 1.701 | OMIT | OMIT | OMIT | 0.120 ± .001 |
| XX-7360F | 1.756 | 0.375 | 0.062 | 0.157 | 0.187 ± .001 |

Figure 11 Industrial Configuration

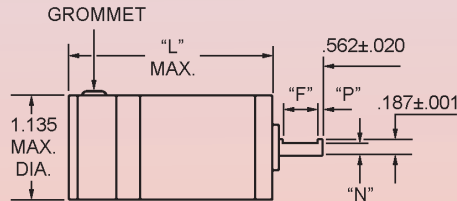

| Model # | "L" | "F" | "P" | "N" |
|----------|-------|-------|-------|-------|
| XX-757A | 2.240 | 0.375 | 0.062 | 0.157 |
| XX-757B | 2.677 | 0.375 | 0.062 | 0.157 |
| XX-796B | 2.677 | OMIT | OMIT | OMIT |
| XX-7483H | 2.677 | 0.375 | 0.062 | 0.157 |

Figure 12 E-Series Tachometers

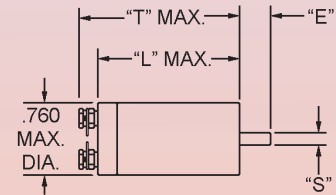

| Model # | "T" | "L" | "E" | "S" |
|----------|-------|-------|--------------|---------------|
| SS-779E | 1.687 | 1.479 | 0.375 ± .015 | 0.120 ± .0005 |
| SS-7251E | 1.687 | 1.479 | 0.562 ± .015 | 0.187 ± .0002 |

Technical Data

An Industry Standard for over fifty years.

Servo-Tek DC tachometer generators provide a convenient and economical means of converting rotational speed into an isolated analog voltage signal suitable for remote indication and control. While this catalog contains information on our most popular models, we also manufacture countless specials.

Construction

Most of our DC generators are housed in aluminum casings protected in accordance with Mil-C-5541 or Mil-A-8625 or high performance plastics. Alnico permanent magnets are used. Armature shafts are stainless-steel, and rotate on fully-shielded stainless-steel ball bearings. Commutators are manufactured from an alloy containing at least 90% silver. Armature laminations are wound with Isomid insulated wire, over Teflon slot insulation. The entire armature is then baked, resulting in a NEMA Class H insulation system.



Ripple

The ripple rms value will not exceed 3% of the DC value at any speed in excess of 40 rpm on standard units. On the low ripple units, the ripple rms value will not exceed 1.5% of the DC value. A peak to peak ripple of 1.5% is available on some models.

Brush Life

Brushes and commutators are matched for long life and stability.

Linearity

Linearity at any speed is better than 0.1% of the output at that rpm.

Bidirectional Operation

All Servo-Tek DC tachometer generators operate in either rotational direction. That direction can be determined by output voltage polarity. Output (in either direction) is held to a tolerance of 0.25% of the average output.



Stability

Optimum brush and commutator combination gives 0.1% stability. Highly stable output gives no evidence of long-term drift.

Breakdown Voltage

Servo-Tek DC tachometer generators are factory tested with an ac potential of 1250 volts rms applied for one second between (either) terminal and shaft. E-Series units are tested with 500 volts.

Temperature Range

Most of our units are designed for continuous operation in ambient temperatures ranging from -55°C to +100°C. Voltage output at 25°C will not deviate by more than 0.01% per degree of change within the range of -20°C to +75°C. All units are temperature compensated, with the exception of D-Series and E-Series units.