

Sold & Serviced By:



Toll Free Phone (877) SERV098

Toll Free Fax (877) SERV099

www.electromate.com

sales@electromate.com

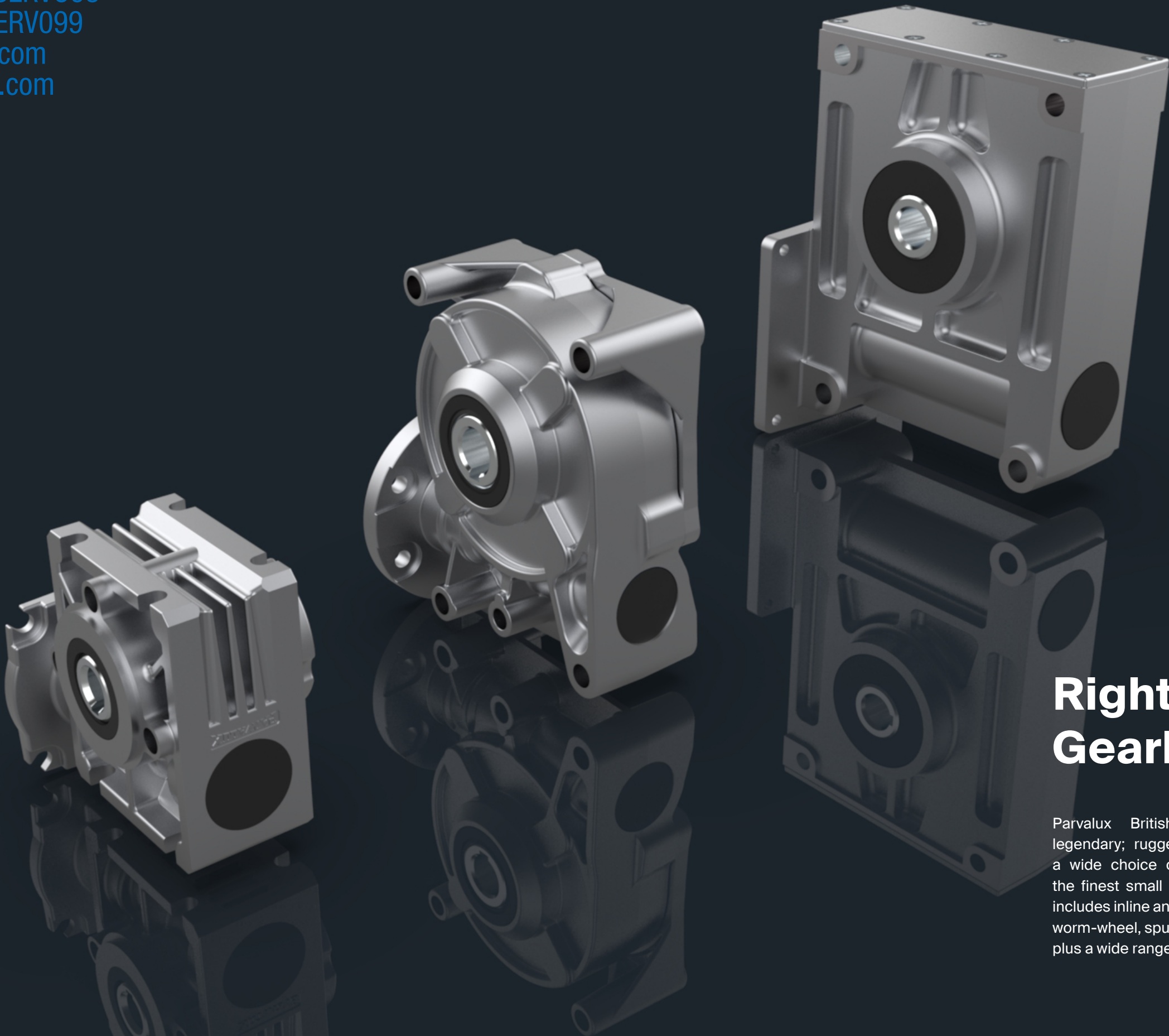

Right-angle Gearboxes

Parvalux British-made gearboxes are simply legendary; rugged, reliable, and designed to suit a wide choice of applications, they are some of the finest small gearboxes in the world. Our range includes inline and right-angle output, with options for worm-wheel, spur and planetary gearboxes available, plus a wide range of customisation options.

S Box

Right-angle gearbox // Composite gears

4:1-70:1 ratio // 4.8 Nm

all dimensions in mm

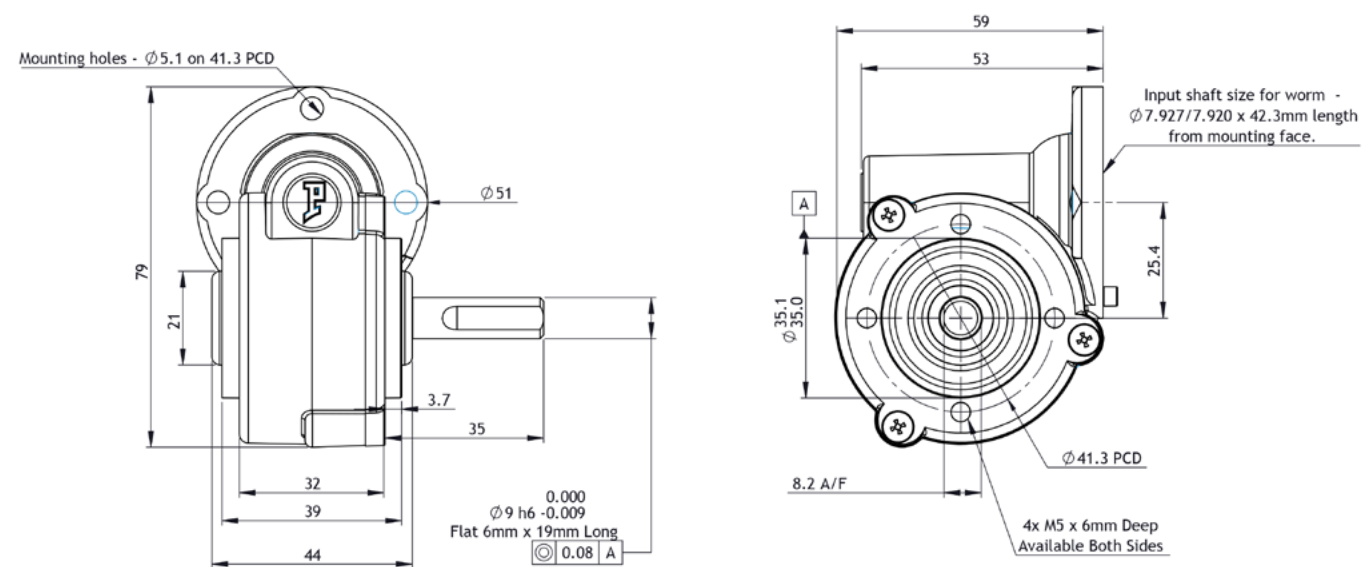

Part number key	
Modular	#####
Standard	#####
Calculated data	#####

*Other ratios available on request (†): 6, 7, 8, 9, 11, 12, 13, 14, 16, 18, 22, 25, 27, 33, 36, 44, 54, 66

Technical data												
1 Part number		-	-	-	-	-	-	-	-	-	-	-
2 Gear ratio ¹	:1	4	5	10	15	20	30	40	48	60	70	
3 Stages		1	1	1	1	1	1	1	1	1	1	
4 Max. continuous torque (S1) ²	Nm	3.0	3.0	3.0	3.0	3.0	3.0	3.0	2.5	2.2	2.0	
5 Max. intermittent torque	Nm	4.8	4.8	4.8	4.8	4.8	4.8	4.8	4.0	3.5	3.2	
6 Efficiency	%	80	80	80	75	70	65	60	55	48	40	
7 Backlash	arc.min	10-25	10-25	10-25	10-25	10-25	10-25	10-25	10-25	10-25	10-25	
8 Max. axial load (dynamic)	N	150	150	150	150	150	150	150	150	150	150	
9 Max. radial load, 12 mm from flange	N	250	250	250	250	250	250	250	250	250	250	
10 Weight	Kg	0.3	0.3	0.3	0.3	0.3	0.3	0.3	0.3	0.3	0.3	
11 Gear material		Composite	Composite	Composite	Composite	Composite	Composite	Composite	Composite	Composite	Composite	

² S1 duty cycle based on 3000 RPM input speed

Modular system

BLDC motor	+L mm	PMDC motor	+L mm
PBL42-15	47	PM7	84
PBL42-30	67	PM8	97
		PM9	110
		PM10	107
		PM11	126

AC motor	+L mm	AC motor	+L mm
SD8	125	SD29	147
SD21	95	SD38	128
SD28	144	SD41	107

+L mm = approximate added length*

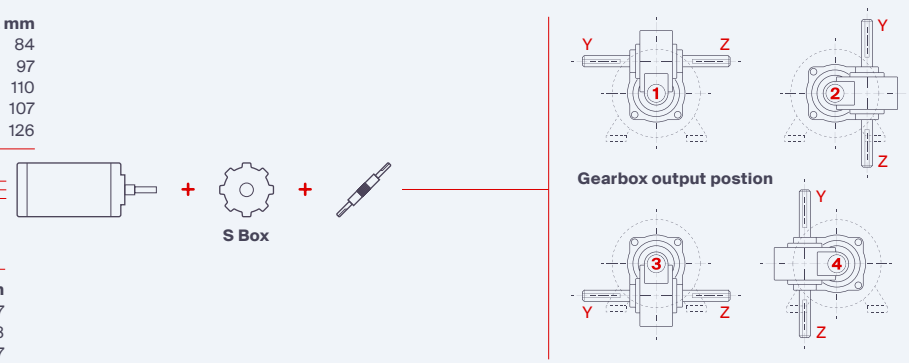

*additional length may also be required for mounting flange between components

S Box

Right-angle gearbox // Bronze gears

4:1-70:1 ratio // 7.2 Nm

all dimensions in mm

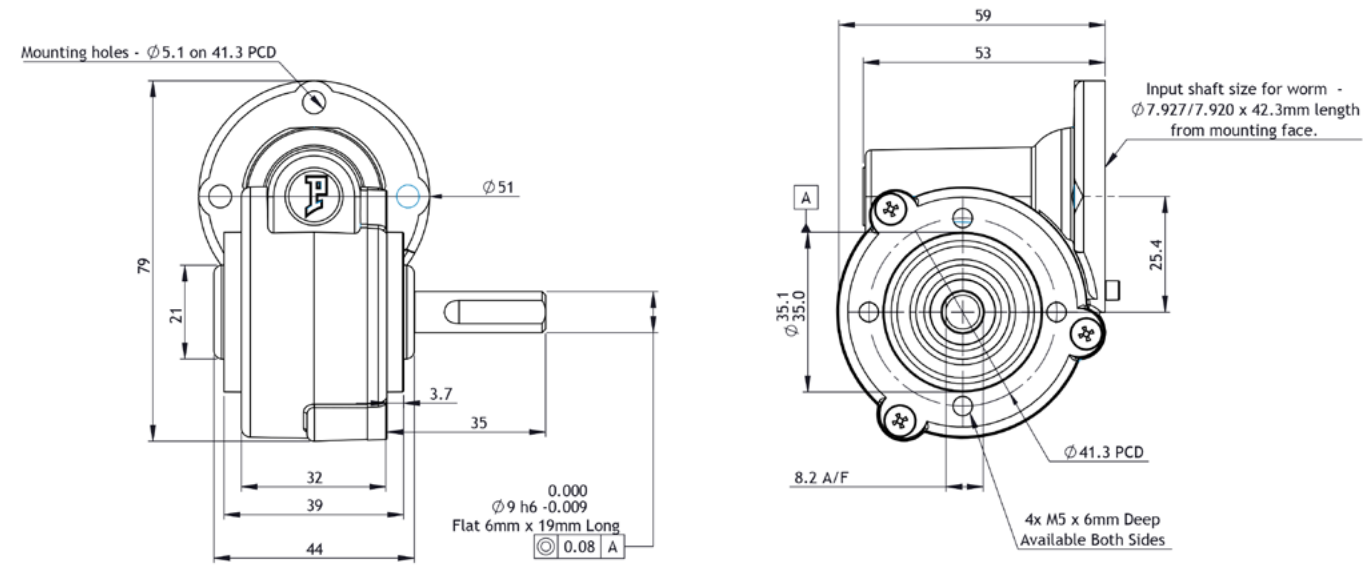

Part number key	
Modular	#####
Standard	#####
Calculated data	#####

*Other ratios available on request (†): 6, 7, 8, 9, 11, 12, 13, 14, 16, 18, 22, 25, 27, 33, 36, 44, 54, 66

Technical data												
1 Part number		-	-	-	-	-	-	-	-	-	-	
2 Gear ratio ¹	:1	4	5	10	15	20	30	40	48	60	70	
3 Stages		1	1	1	1	1	1	1	1	1	1	
4 Max. continuous torque (S1) ²	Nm	4.5	4.5	4.5	4.5	4.5	4.5	4.5	3.8	3.3	3.0	
5 Max. intermittent torque	Nm	7.2	7.2	7.2	7.2	7.2	7.2	7.2	6.0	5.3	4.8	
6 Efficiency	%	70	70	70	65	61	57	52	48	42	35	
7 Backlash	arc.min	10-25	10-25	10-25	10-25	10-25	10-25	10-25	10-25	10-25	10-25	
8 Max. axial load (dynamic)	N	150	150	150	150	150	150	150	150	150	150	
9 Max. radial load, 12 mm from flange	N	250	250	250	250	250	250	250	250	250	250	
10 Weight	Kg	0.4	0.4	0.4	0.4	0.4	0.4	0.4	0.4	0.4	0.4	
11 Gear material		Bronze	Bronze	Bronze	Bronze	Bronze	Bronze	Bronze	Bronze	Bronze	Bronze	

² S1 duty cycle based on 3000 RPM input speed

Modular system

BLDC motor	+L mm	PMDC motor	+L mm
PBL42-15	47	PM7	84
PBL42-30	67	PM8	97
		PM9	110
		PM10	107
		PM11	126

AC motor	+L mm	AC motor	+L mm
SD8	125	SD29	147
SD21	95	SD38	128
SD28	144	SD41	107

+L mm = approximate added length*

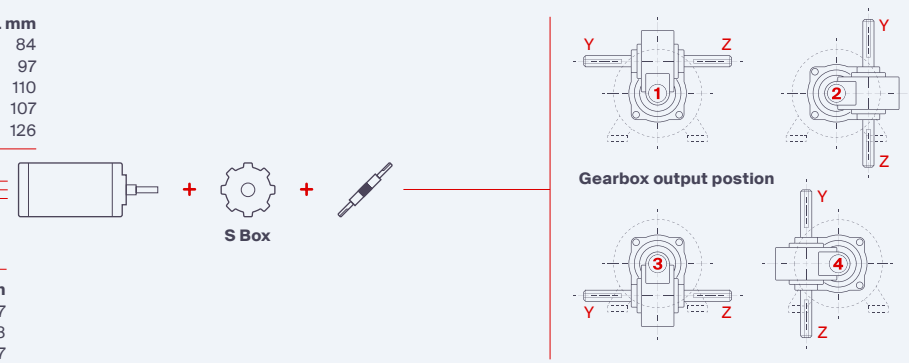

*additional length may also be required for mounting flange between components

GB28 Right-angle gearbox // Bronze gears

15:1 - 60:1 ratio // 8.0 Nm

all dimensions in mm

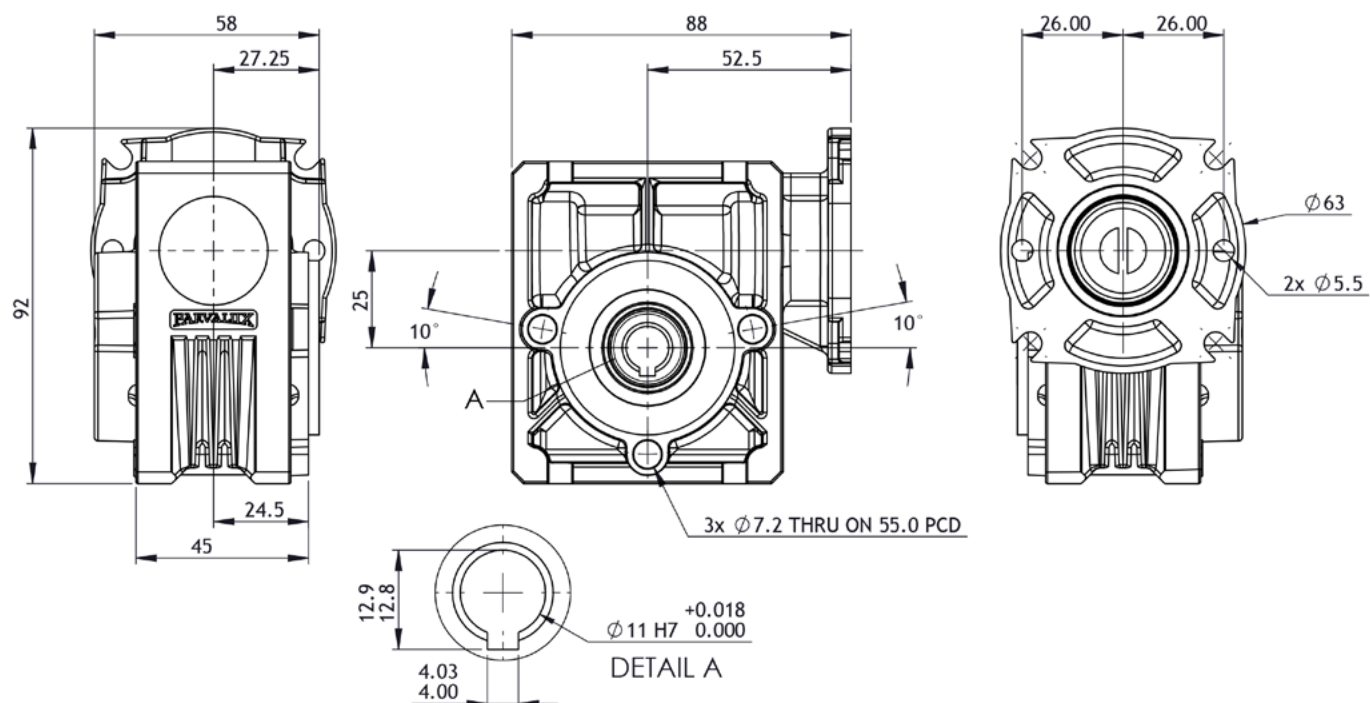

Part number key						
Modular	#####					
Standard	#####					
Calculated data	#####					
Technical data						
1 Part number		735904	-	735906	-	735907
2 Gear ratio	:1	15	25	30	50	60
3 Stages		1	1	1	1	1
4 Max. continuous torque (S1) ¹	Nm	5.0	5.0	5.0	5.0	5.0
5 Max. intermittent torque	Nm	8.0	8.0	8.0	8.0	8.0
6 Efficiency	%	75	70	65	50	45
7 Backlash	arc.min	10-25	10-25	10-25	10-25	10-25
8 Max. axial load (dynamic)	N	300	300	300	300	300
9 Max. radial load, 12 mm from flange	N	400	400	400	400	400
10 Weight	Kg	0.83	0.83	0.83	0.83	0.83
11 Gear material		Bronze	Bronze	Bronze	Bronze	Bronze

¹ S1 duty cycle based on 3000 RPM input speed

Modular system

BLDC motor	+L mm
BLx60-40	85
PBL60-50	90
PBL60-70	110

+L mm = approximate added length*

PMDc motor	+L mm
BRx52-30	95
BRx52-58	125
BRx63-40	95
BRx63-55	125

+L mm = approximate added length*

Shaft extension kit 735908

Gearbox output position 1, 2, 3, 4

*additional length may also be required for mounting flange between components

GB58 Right-angle gearbox // Composite gears

4:1 - 25:1 ratio // 8.0 Nm

all dimensions in mm

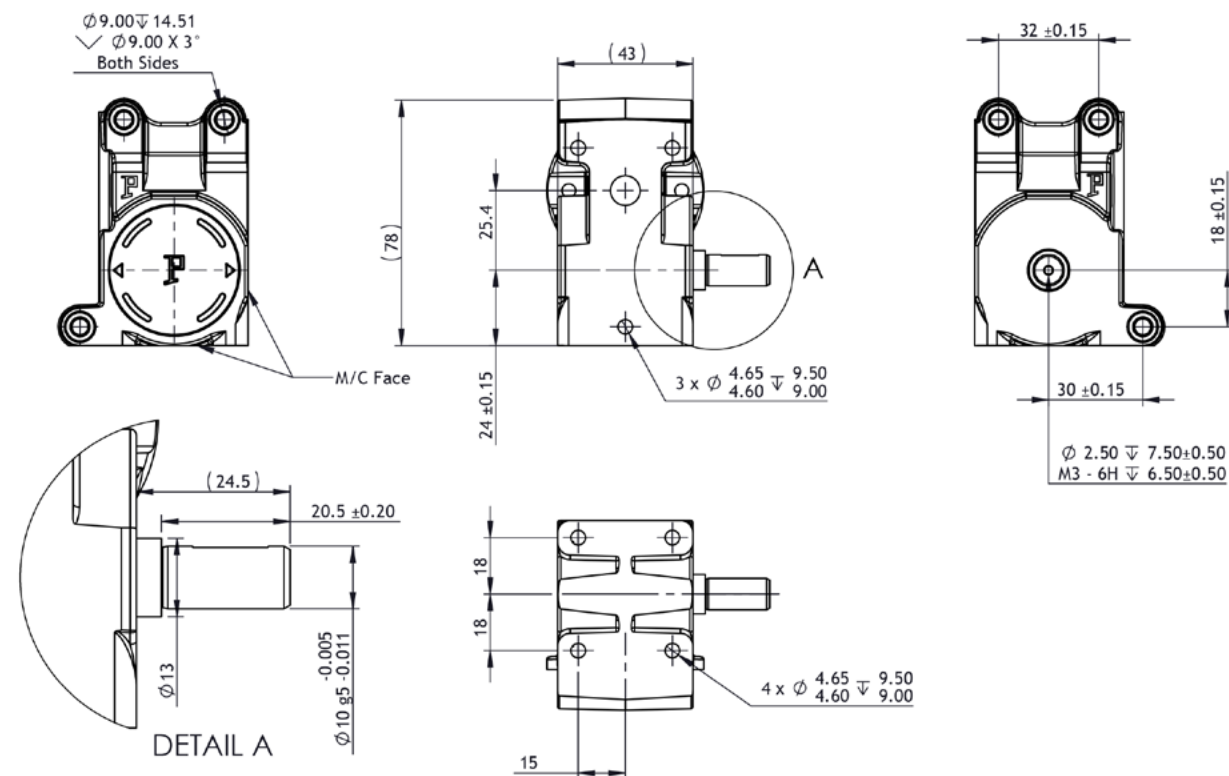

Part number key												
Modular	#####											
Standard	#####											
Calculated data	#####											
Technical data												
1 Part number		-	-	-	-	-	-	-	-	-	-	-
2 Gear ratio ¹	:1	4	5	7	9	10	14	15	18	20	25	
3 Stages		1	1	1	1	1	1	1	1	1	1	
4 Max. continuous torque (S1) ²	Nm	4.0	4.0	4.0	4.0	4.0	4.0	4.0	4.0	4.0	4.0	
5 Max. intermittent torque	Nm	8.0	8.0	8.0	8.0	8.0	8.0	8.0	8.0	8.0	8.0	
6 Efficiency	%	85	84	82	80	80	76	75	73	72	68	
7 Backlash	arc.min	10-25	10-25	10-25	10-25	10-25	10-25	10-25	10-25	10-25	10-25	
8 Max. axial load (dynamic)	N	300	300	300	300	300	300	300	300	300	300	
9 Max. radial load, 12 mm from flange	N	400	400	400	400	400	400	400	400	400	400	
10 Weight	Kg	0.4	0.4	0.4	0.4	0.4	0.4	0.4	0.4	0.4	0.4	
11 Gear material		Composite	Composite	Composite	Composite	Composite	Composite	Composite	Composite	Composite	Composite	

Notes: Custom shaft available on request, max diameter 20mm. Double exit and hollow shaft (11mm bore) available. Casting finish - shot blast with m/c features (powder coating on request)

¹ Other ratios available on request (1): 6, 8, 11, 12, 13, 16, 22

² S1 duty cycle based on 2000 RPM input speed

Modular system

PMDc motor	+L mm
BRx52-30	95
BRx52-58	125
BRx63-40	110
BRx63-55	125

+L mm = approximate added length*

BLDC motor	+L mm
PBL42-15	47
PBL42-30	67
PBL60-50	90
PBL60-70	110

+L mm = approximate added length*

Gearbox output position 1, 2, 3, 4

*additional length may also be required for mounting flange between components

M Box

Right-angle gearbox // Composite gears

4:1 - 72:1 ratio // 13.0 Nm

all dimensions in mm

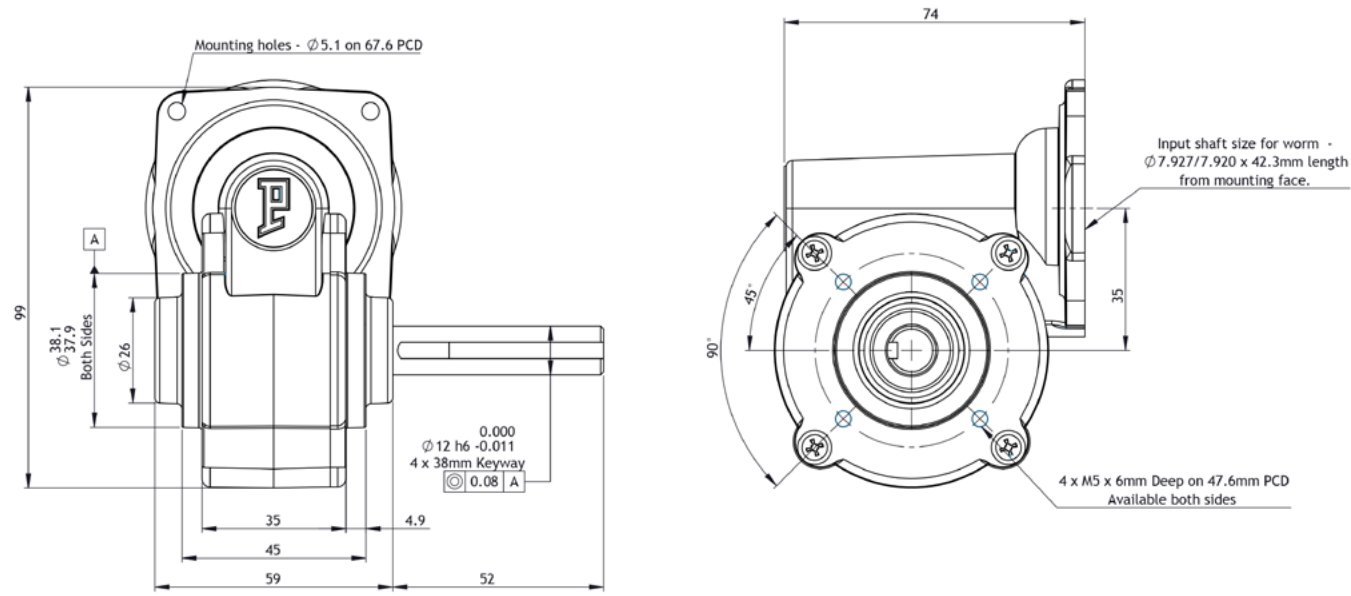

Part number key											
Modular	#####										
Standard	#####										
Calculated data	#####										
*Other ratios available on request (!): 6, 8, 9, 12, 13, 14, 18, 25, 33, 44, 54, 66											
Technical data											
1 Part number	-	-	-	-	-	-	-	-	-	-	-
2 Gear ratio ¹	:1	4	5	10	16	20	30	40	48	60	72
3 Stages	1	1	1	11	1	1	1	1	1	1	1
4 Max. continuous torque (S1) ²	Nm	8.0	8.0	8.0	8.0	8.0	8.0	8.0	8.0	6.0	5.0
5 Max. intermittent torque	Nm	13.0	13.0	13.0	13.0	13.0	13.0	13.0	13.0	10.0	8.0
6 Efficiency	%	85	85	82	77	74	70	65	58	54	46
7 Backlash	arc.min	10-25	10-25	10-25	10-25	10-25	10-25	10-25	10-25	10-25	10-25
8 Max. axial load (dynamic)	N	300	300	300	300	300	300	300	300	300	300
9 Max. radial load, 12 mm from flange	N	350	350	350	350	350	350	350	350	350	350
10 Weight	Kg	0.7	0.7	0.7	0.7	0.7	0.7	0.7	0.7	0.7	0.7
11 Gear material		Composite	Composite	Composite	Composite	Composite	Composite	Composite	Composite	Composite	Composite

² S1 duty cycles based on 3000 RPM input speed

Compatible products

BLDC motor	+L mm	AC motor	+L mm	AC motor	+L mm
PBL60-50	90	SD8	125	SD28	144
PBL60-70	110	SD13	152	SD29	147
		SD18	158	SD38	128
		SD21	95	SD41	107

PMDC motor	+L mm	PMDC motor	+L mm
PM1	149	PM6	175
PM2	162	PM10	107
PM3	137	PM11	126
PM4	149	PM50	180
PM5	162	PM60	193

+L mm = approximate added length*

*additional length may also be required for mounting flange between components

M Box

Right-angle gearbox // Bronze gears

4:1 - 72:1 ratio // 19.0 Nm

all dimensions in mm

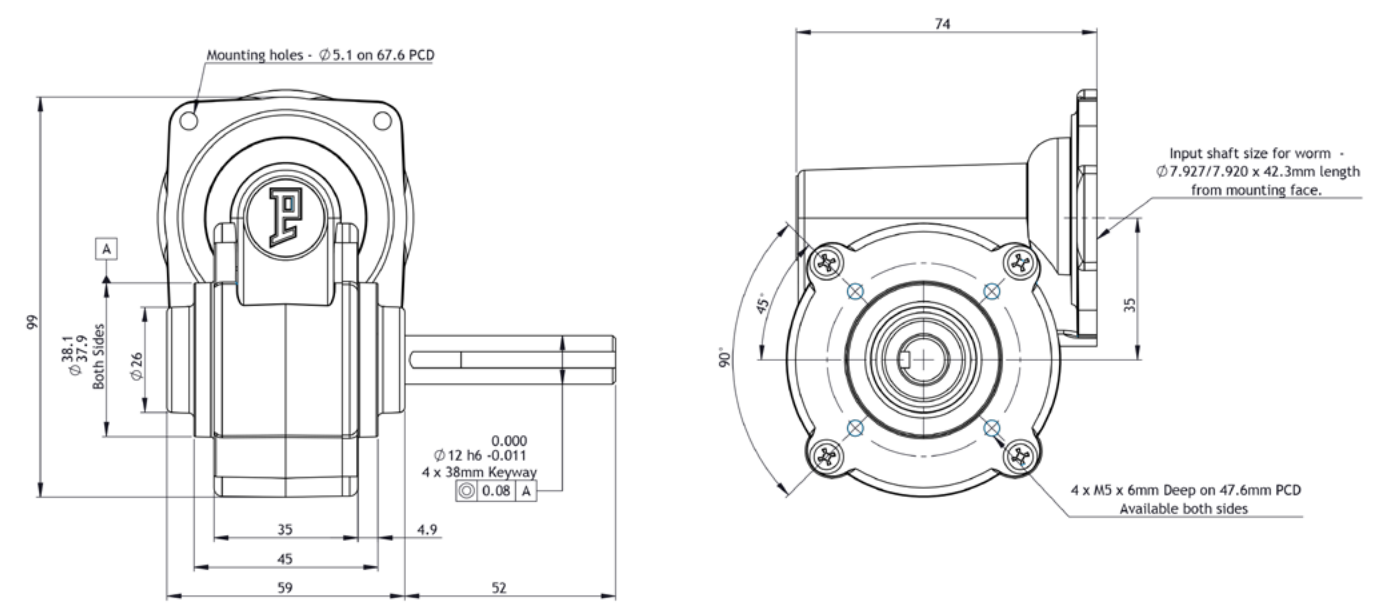

Part number key											
Modular	#####										
Standard	#####										
Calculated data	#####										
*Other ratios available on request (!): 6, 8, 9, 12, 13, 14, 18, 25, 33, 44, 54, 66											
Technical data											
1 Part number	-	-	-	-	-	-	-	-	-	-	-
2 Gear ratio ¹	:1	4	5	10	16	20	30	40	48	60	72
3 Stages	1	1	1	11	1	1	1	1	1	1	1
4 Max. continuous torque (S1) ²	Nm	12.0	12.0	12.0	12.0	12.0	12.0	12.0	12.0	9.0	8.0
5 Max. intermittent torque	Nm	19.0	19.0	19.0	19.0	19.0	19.0	19.0	19.0	14.0	12.0
6 Efficiency	%	74	74	71	67	64	61	57	50	47	40
7 Backlash	arc.min	10-25	10-25	10-25	10-25	10-25	10-25	10-25	10-25	10-25	10-25
8 Max. axial load (dynamic)	N	300	300	300	300	300	300	300	300	300	300
9 Max. radial load, 12 mm from flange	N	350	350	350	350	350	350	350	350	350	350
10 Weight	Kg	0.9	0.9	0.9	0.9	0.9	0.9	0.9	0.9	0.9	0.9
11 Gear material		Bronze	Bronze	Bronze	Bronze	Bronze	Bronze	Bronze	Bronze	Bronze	Bronze

² S1 duty cycle based on 3000 RPM input speed

Modular system

BLDC motor	+L mm	AC motor	+L mm	AC motor	+L mm
PBL60-50	90	SD8	125	SD28	144
PBL60-70	110	SD13	152	SD29	147
		SD18	158	SD38	128
		SD21	95	SD41	107

PMDC motor	+L mm	PMDC motor	+L mm
PM1	149	PM6	175
PM2	162	PM10	107
PM3	137	PM11	126
PM4	149	PM50	180
PM5	162	PM60	193

+L mm = approximate added length*

*additional length may also be required for mounting flange between components

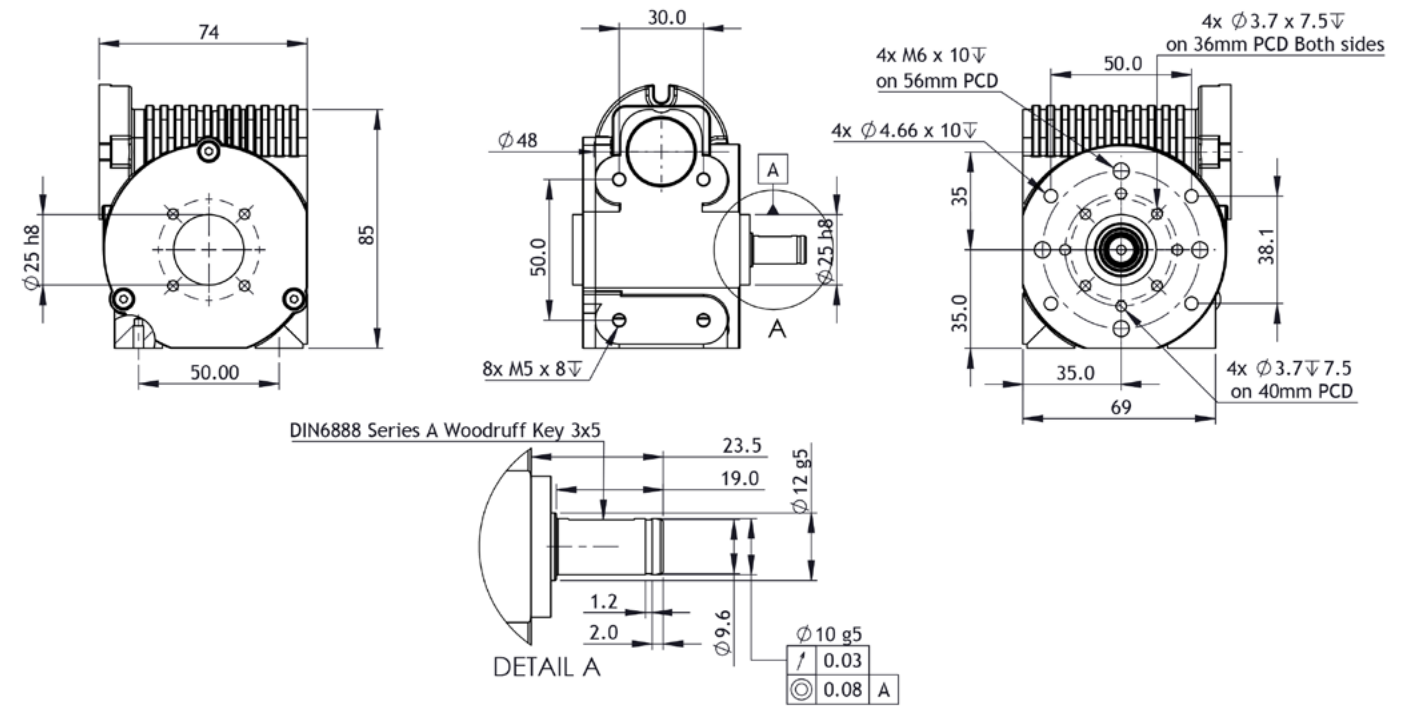
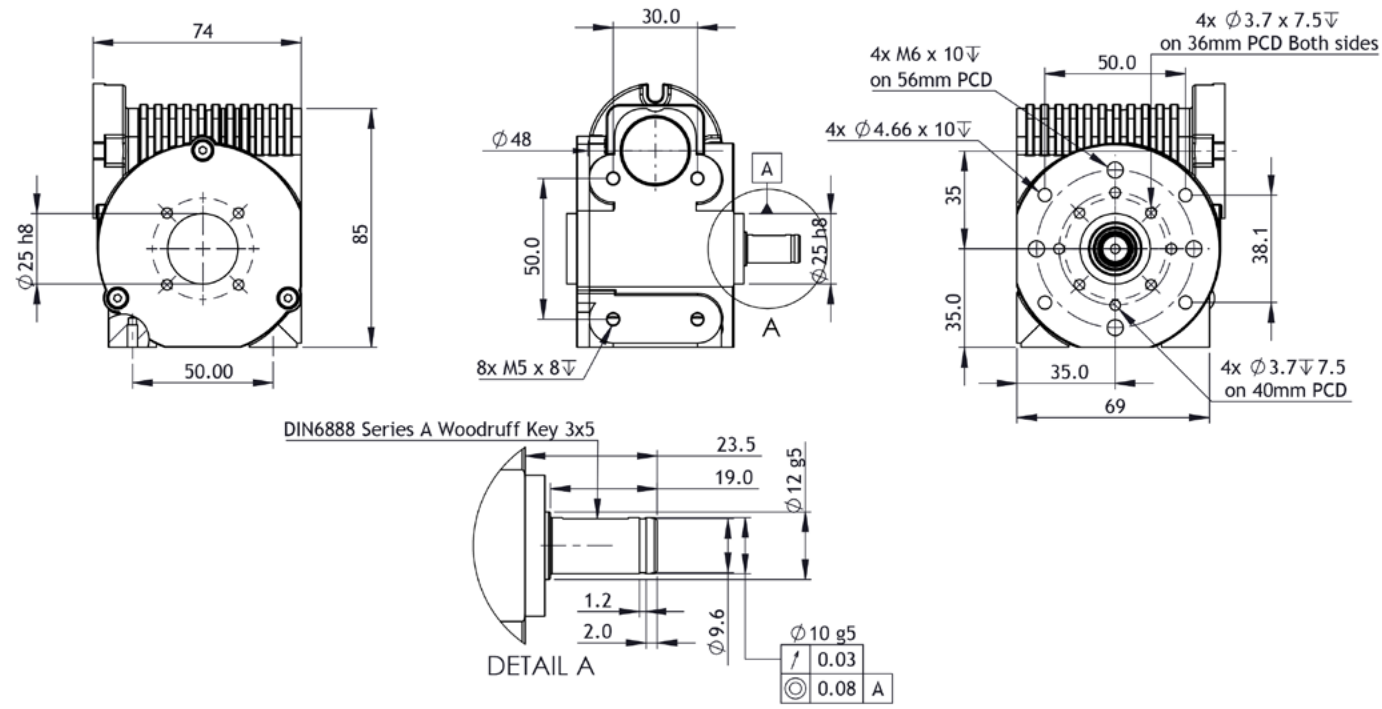

Part number key											
Modular	#####	Notes: Custom shaft available on request.									
Standard	#####	Other ratios available on request (1): 5, 8, 9, 12, 13, 14, 18, 25, 33, 44, 48, 66									
Calculated data	#####										
Technical data											
1 Part number	-	-	-	-	-	-	-	-	-	-	-
2 Gear ratio ¹	:1	4	6	10	16	20	30	40	54	60	72
3 Stages	1	1	1	1	1	1	1	1	1	1	1
4 Max. continuous torque (S1) ²	Nm	8.0	8.0	8.0	8.0	8.0	8.0	8.0	7.0	6.0	5.0
5 Max. intermittent torque	Nm	13.0	13.0	13.0	13.0	13.0	13.0	13.0	11.0	10.0	8.0
6 Efficiency	%	85	85	82	77	74	70	65	56	54	46
7 Backlash	arc.min	10-25	10-25	10-25	10-25	10-25	10-25	10-25	10-25	10-25	10-25
8 Max. axial load (dynamic)	N	300	300	300	300	300	300	300	300	300	300
9 Max. radial load, 12 mm from flange	N	350	350	350	350	350	350	350	350	350	350
10 Weight	Kg	0.7	0.7	0.7	0.7	0.7	0.7	0.7	0.7	0.7	0.7
11 Gear material		Composite	Composite	Composite	Composite	Composite	Composite	Composite	Composite	Composite	Composite

² S1 duty cycle based on 2000 RPM input speed

Modular system

Motor	+L mm
PMDC motor	
BRx63-40	110
BRx63-55	125
BRx70-40	125
BRx70-60	146
BLDC motor	
BLx60-40	85
PBL60-50	90
PBL60-70	110

+L mm = approximate added length*

*additional length may also be required for mounting flange between components

Part number key											
Modular	#####	Notes: Custom shaft available on request, max diameter 20mm. Double exit and hollow shaft (11mm bore) available. Casting finish - shot blast with m/c features (powder coating on request)									
Standard	#####	Other ratios available on request (1): 6, 8, 11, 12, 13, 16, 22									
Calculated data	#####										
Technical data											
1 Part number	-	-	-	-	-	-	-	-	-	-	-
2 Gear ratio ¹	:1	4	6	10	16	20	30	40	54	60	72
3 Stages	1	1	1	1	1	1	1	1	1	1	1
4 Max. continuous torque (S1) ²	Nm	12.0	12.0	12.0	12.0	12.0	12.0	12.0	11.0	9.0	8.0
5 Max. intermittent torque	Nm	19.0	19.0	19.0	19.0	19.0	19.0	19.0	17.0	14.0	12.0
6 Efficiency	%	74	74	71	67	64	61	57	49	47	40
7 Backlash	arc.min	10-25	10-25	10-25	10-25	10-25	10-25	10-25	10-25	10-25	10-25
8 Max. axial load (dynamic)	N	300	300	300	300	300	300	300	300	300	300
9 Max. radial load, 12 mm from flange	N	350	350	350	350	350	350	350	350	350	350
10 Weight	Kg	0.9	0.9	0.9	0.9	0.9	0.9	0.9	0.9	0.9	0.9
11 Gear material		Bronze	Bronze	Bronze	Bronze	Bronze	Bronze	Bronze	Bronze	Bronze	Bronze

² S1 duty cycle based on 2000 RPM input speed

Modular system

Motor	+L mm
PMDC motor	
BRx63-40	110
BRx63-55	125
BRx70-40	125
BRx70-60	146
BLDC motor	
BLx60-40	85
PBL60-50	90
PBL60-70	110

+L mm = approximate added length*

*additional length may also be required for mounting flange between components

GB12 Right-angle gearbox // Composite gears

12.5:1 - 75:1 ratio // 32.0 Nm

all dimensions in mm

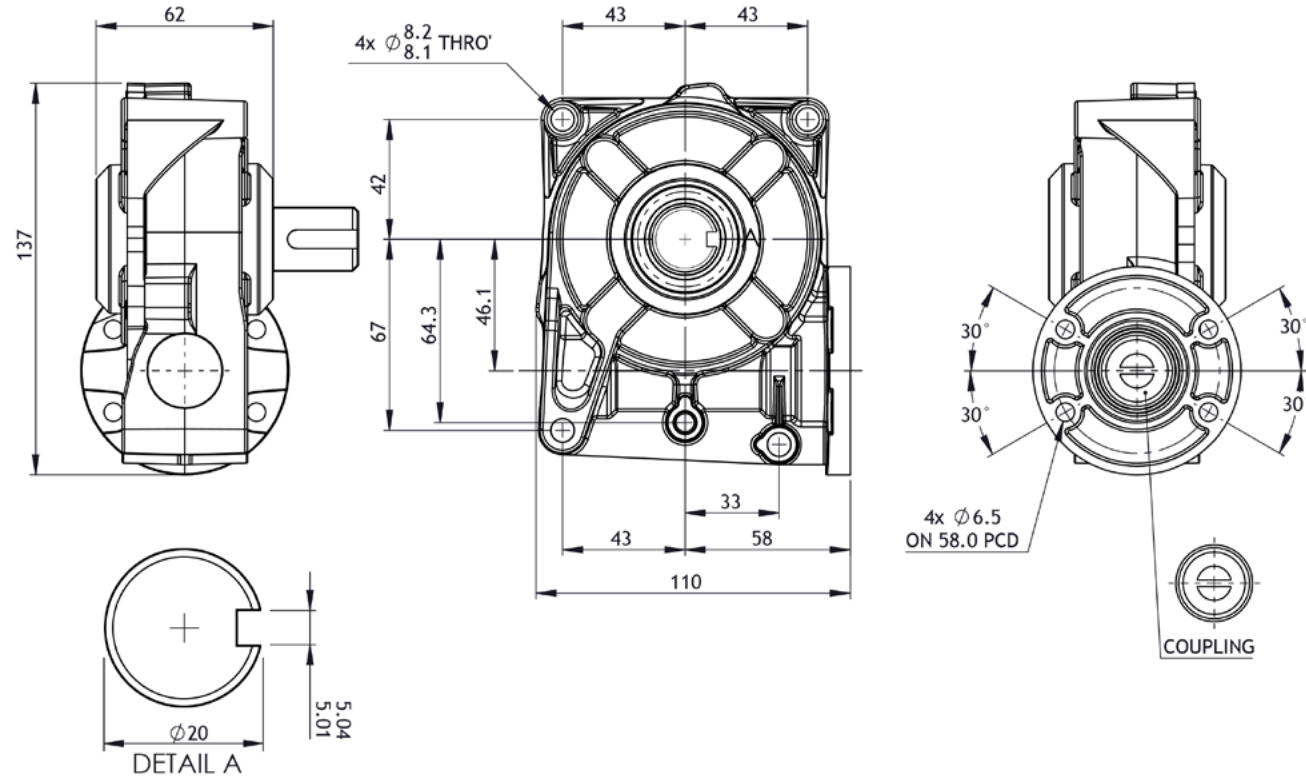

Part number key											
Modular	#####										
Standard	#####										
Calculated data	#####										
Technical data											
1 Part number	-	-	-	-	-	-	-	-	-	-	-
2 Gear ratio	:1	12.5	14	15	19	21	25	30	50	60	75
3 Stages	1	1	1	1	1	1	1	1	1	1	1
4 Max. continuous torque (S1) ¹	Nm	20.0	20.0	20.0	20.0	20.0	20.0	20.0	20.0	20.0	18.0
5 Max. intermittent torque	Nm	32.0	32.0	32.0	32.0	32.0	32.0	32.0	32.0	32.0	29.0
6 Efficiency	%	85	83	83	80	78	75	72	60	55	50
7 Backlash	arc.min	10-25	10-25	10-25	10-25	10-25	10-25	10-25	10-25	10-25	10-25
8 Max. axial load (dynamic)	N	300	300	300	300	300	300	300	300	300	300
9 Max. radial load, 12 mm from flange	N	500	500	500	500	500	500	500	500	500	500
10 Weight	Kg	1.1	1.1	1.1	1.1	1.1	1.1	1.1	1.1	1.1	1.1
11 Gear material		Composite	Composite	Composite	Composite	Composite	Composite	Composite	Composite	Composite	Composite

¹ S1 duty cycle based on 3000 RPM input speed

Modular system

BLDC motor	+L mm	BLDC motor	+L mm
BLx60-40	85	PBL70-70	114
PBL60-50	90	PBL70-80	124
PBL60-70	110	PBL86-55	111
		PBL86-80	136

PMDC motor	+L mm
BRx70-40	125
BRx70-60	146
BRx90-50	153
BRx90-75	183

Shaft extension kit 735903

*additional length may also be required for mounting flange between components

GB12 Right-angle gearbox // Bronze gears

12.5:1 - 75:1 ratio // 48.0 Nm

all dimensions in mm

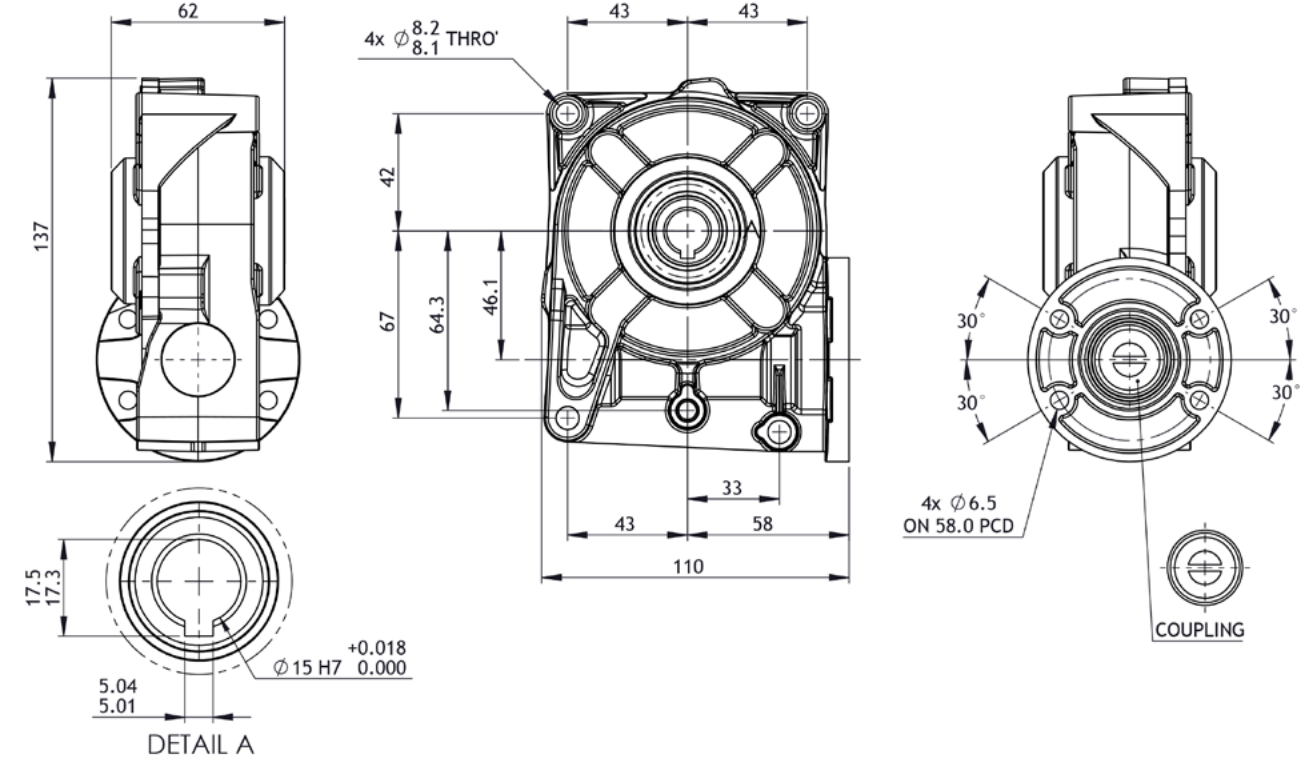

Part number key											
Modular	#####										
Standard	#####										
Calculated data	#####										
Technical data											
1 Part number	-	-	-	735900	-	-	-	735901	-	735902	-
2 Gear ratio	:1	12.5	14	15	19	21	25	30	50	60	75
3 Stages	1	1	1	1	1	1	1	1	1	1	1
4 Max. continuous torque (S1) ¹	Nm	30.0	30.0	30.0	30.0	30.0	30.0	30.0	30.0	30.0	27.0
5 Max. intermittent torque	Nm	48.0	48.0	48.0	48.0	48.0	48.0	48.0	48.0	48.0	43.0
6 Efficiency	%	80	75	75	73	73	72	65	55	50	45
7 Backlash	arc.min	10-25	10-25	10-25	10-25	10-25	10-25	10-25	10-25	10-25	10-25
8 Max. axial load (dynamic)	N	600	600	600	600	600	600	600	600	600	600
9 Max. radial load, 12 mm from flange	N	800	800	800	800	800	800	800	800	800	800
10 Weight	Kg	1.5	1.5	1.5	1.5	1.5	1.5	1.5	1.5	1.5	1.5
11 Gear material		Bronze	Bronze	Bronze	Bronze	Bronze	Bronze	Bronze	Bronze	Bronze	Bronze

¹ S1 duty cycle based on 3000 RPM input speed

Modular system

BLDC motor	+L mm	BLDC motor	+L mm
BLx60-40	85	PBL70-70	114
PBL60-50	90	PBL70-80	124
PBL60-70	110	PBL86-55	111
		PBL86-80	136

PMDC motor	+L mm
BRx70-40	125
BRx70-60	146
BRx90-50	153
BRx90-75	183

Shaft extension kit 735903

*additional length may also be required for mounting flange between components

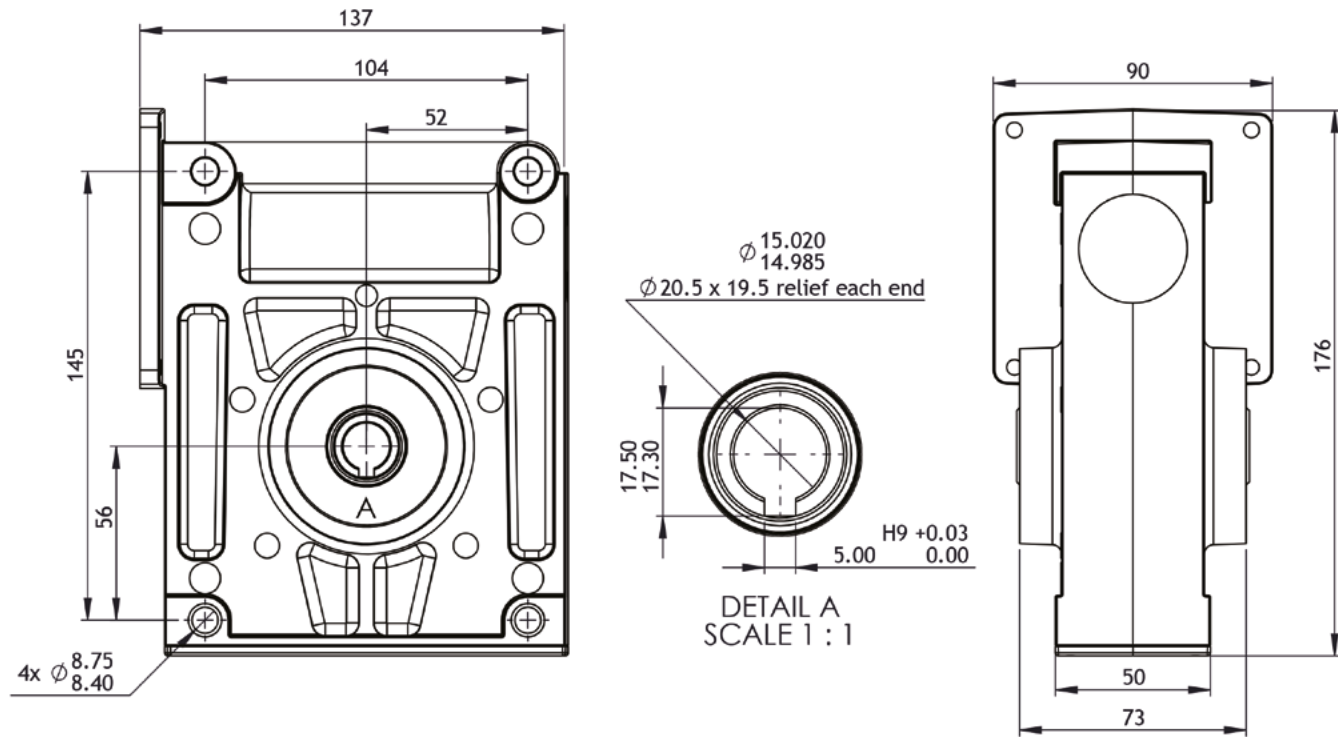

Part number key									
Modular	#####								
Standard	#####								
Calculated data	#####								
Technical data									
1 Part number	-	735894	-	735895	-	735896	-	-	-
2 Gear ratio	:1	12.5	15	25	30	40	60	75	
3 Stages		1	1	1	1	1	1	1	1
4 Max. continuous torque (S1) ¹	Nm	50.0	50.0	50.0	50.0	50.0	50.0	40.0	
5 Max. intermittent torque	Nm	80.0	80.0	80.0	80.0	80.0	80.0	70.0	
6 Efficiency	%	90	85	80	75	70	65	50	
7 Backlash	arc.min	10-25	10-25	10-25	10-25	10-25	10-25	10-25	
8 Max. axial load (dynamic)	N	600	600	600	600	600	600	600	
9 Max. radial load, 12 mm from flange	N	800	800	800	800	800	800	800	
10 Weight	Kg	2.3	2.3	2.3	2.3	2.3	2.3	2.3	
11 Gear material		Composite	Composite	Composite	Composite	Composite	Composite	Composite	

¹S1 duty cycle based on 3000 RPM input speed

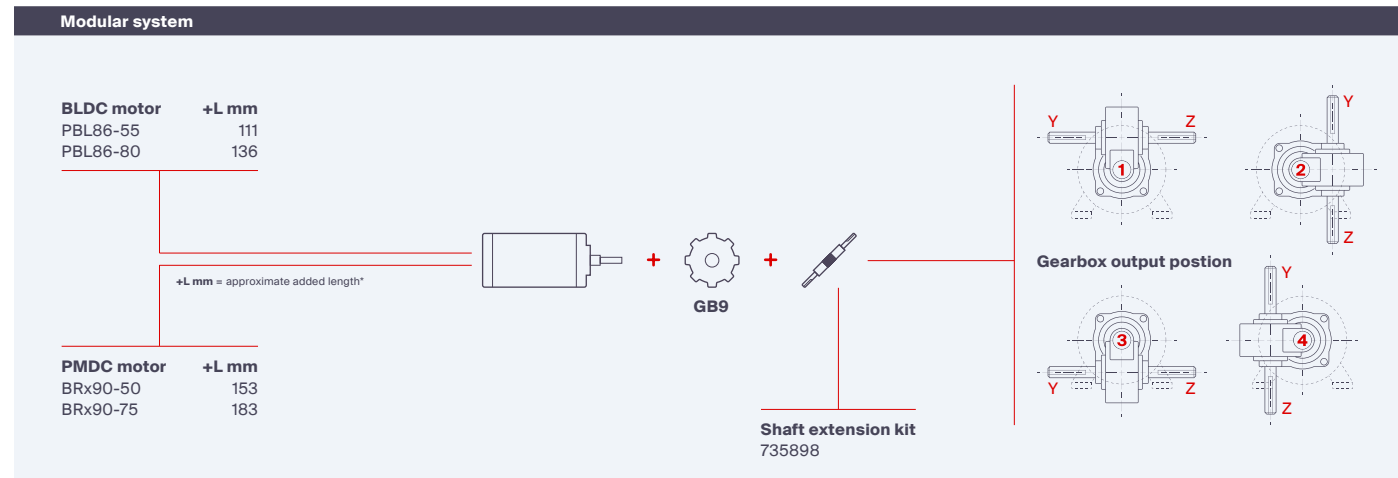

*additional length may also be required for mounting flange between components

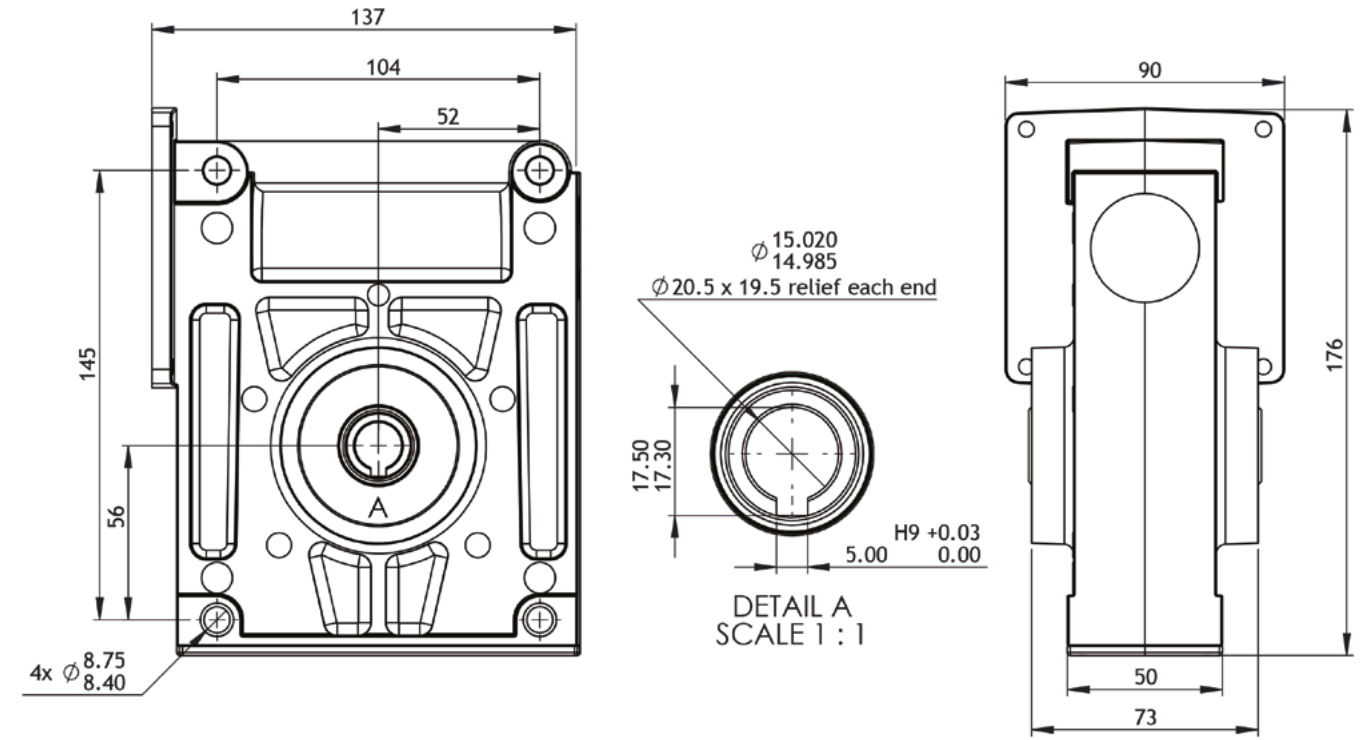

Part number key									
Modular	#####								
Standard	#####								
Calculated data	#####								
Technical data									
1 Part number	-	-	-	-	-	-	-	-	-
2 Gear ratio	:1	12.5	15	25	30	40	60	75	
3 Stages		1	1	1	1	1	1	1	1
4 Max. continuous torque (S1) ¹	Nm	75.0	75.0	75.0	75.0	75.0	75.0	60.0	
5 Max. intermittent torque	Nm	120.0	120.0	120.0	120.0	120.0	120.0	96.0	
6 Efficiency	%	85	80	75	70	65	55	45	
7 Backlash	arc.min	10-25	10-25	10-25	10-25	10-25	10-25	10-25	
8 Max. axial load (dynamic)	N	600	600	600	600	600	600	600	
9 Max. radial load, 12 mm from flange	N	800	800	800	800	800	800	800	
10 Weight	Kg	3.4	3.4	3.4	3.4	3.4	3.4	3.4	
11 Gear material		Bronze	Bronze	Bronze	Bronze	Bronze	Bronze	Bronze	

¹S1 duty cycle based on 3000 RPM input speed

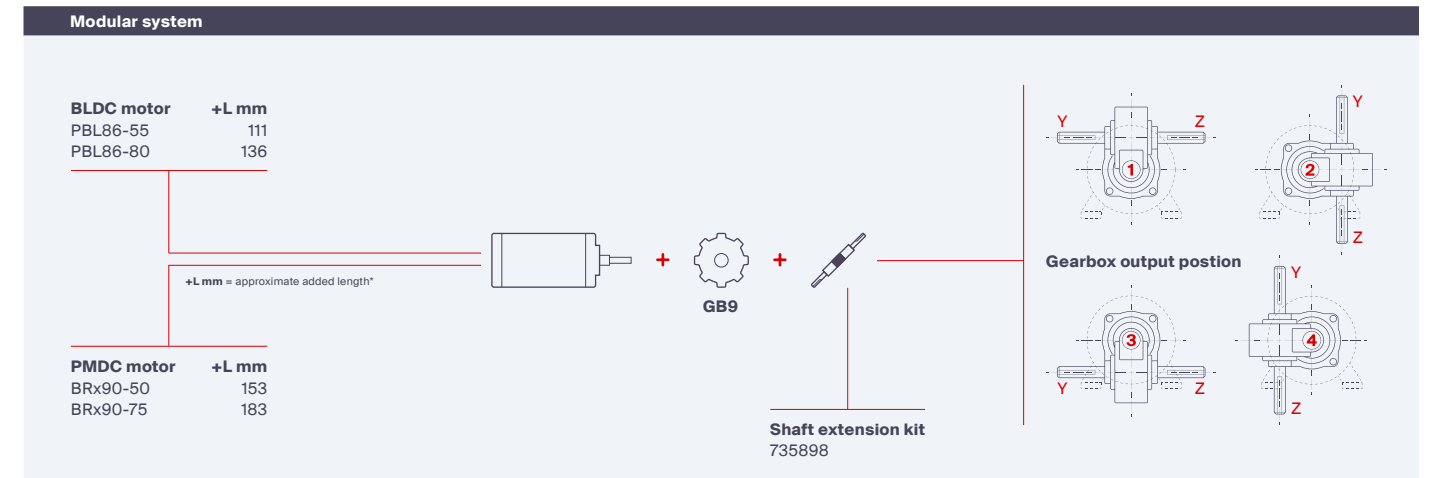

*additional length may also be required for mounting flange between components

