

# Gearhead Ordering Information

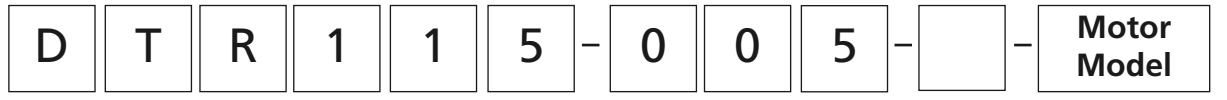

**Designates Gearhead Type**

- NT = NemaTRUE\*
- NTP = NemaTRUE PLUS\*
- NTR = NemaTRUE 90\*
- DT = DuraTRUE\*
- DTR = DuraTRUE 90\*
- UT = UltraTRUE\*
- UTR = UltraTRUE 90\*
- ET = EverTRUE
- EQ = EQ Series

**Gearhead Ratio**  
See Ratio Availability in corresponding gearhead section

**Custom Options**  
Special = S  
None = 0

Motor Model Number

**GEARHEAD SIZE**

**NemaTRUE  
NemaTRUE PLUS  
NemaTRUE 90**

- 17 = Size 17
- 23 = Size 23
- 34 = Size 34
- 42 = Size 42
- 60 = Size 60
- 90 = Size 90
- 115 = Size 115

**DuraTRUE  
DuraTRUE 90  
DuraTRUE Hollow Shaft  
DuraTRUE Dual Shaft**

- 60 = Size 60
- 90 = Size 90
- 115 = Size 115
- 142 = Size 142

**UltraTRUE  
UltraTRUE 90**

- 006 = Size 60
- 075 = Size 75
- 090 = Size 90
- 010 = Size 10
- 115 = Size 115
- 014 - Size 14
- 018 - Size 18
- 018t - Size 18t
- 022 = Size 22  
(UltraTRUE ONLY)

**EverTRUE**

- 10 = Size 10
- 14 = Size 14
- 18 = Size 18

**EQ**

- 23 / 60 = Size 23 / 60mm

Sold & Serviced By:  
  
 Toll Free Phone (877) SERV098  
 Toll Free Fax (877) SERV099  
[www.electromate.com](http://www.electromate.com)  
[sales@electromate.com](mailto:sales@electromate.com)



©2003 Danaher Motion. Printed in the U.S.A. The specifications in this publication are believed to be accurate and reliable. However, it is the responsibility of the product user to determine the suitability of Micron products for a specific application. While defective products will be replaced without charge if promptly returned, no liability is assumed beyond such replacement.

\* Trademark of Danaher Motion. DANAHER MOTION is registered in the U.S. Patent and Trademark Office and in other countries.

# NemaTRUE 90\*

## Right Angle Gearheads

*Ready for Immediate Delivery*

**Precision:** 13 arc-minutes  
**Frame Sizes:** 23, 34, and 42  
**Torque Capacity:** up to 2255 in-lb

**Ratio Availability:** 1:1 thru 500:1  
**Radial load capacity:** up to 650 lb  
**Mounting system:** RediMount\*

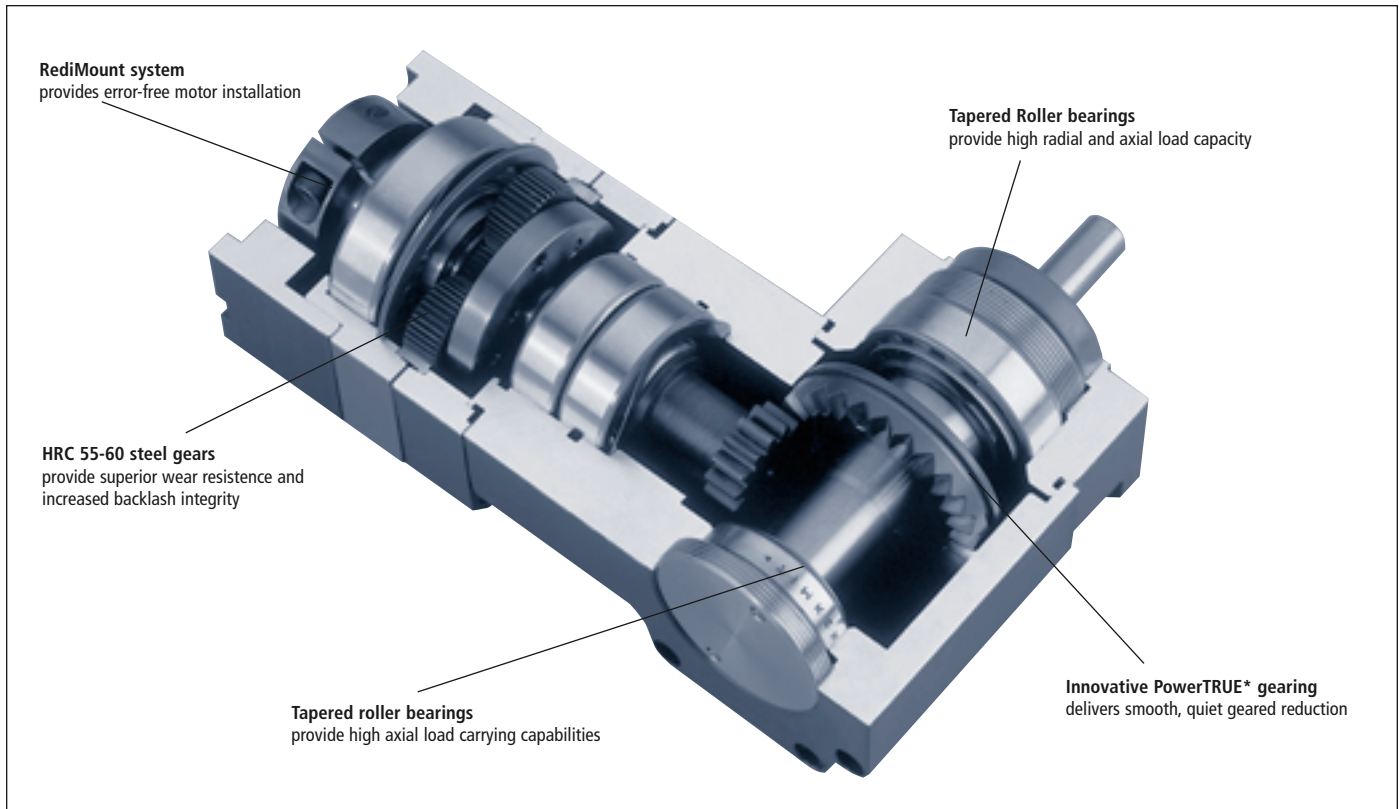

Index	Page
NemaTRUE 90 Size 23 Planetary Gearhead	.18
NemaTRUE 90 Size 34 Planetary Gearhead	.19
NemaTRUE 90 Size 42 Planetary Gearhead	.20
Selection	.10
Mounting Tools	.84

Sold & Serviced By:  
  
 Toll Free Phone (877) SERV098  
 Toll Free Fax (877) SERV099  
[www.electromate.com](http://www.electromate.com)  
[sales@electromate.com](mailto:sales@electromate.com)

**MICRON**

©2003 Danaher Motion. Printed in the U.S.A. The specifications in this publication are believed to be accurate and reliable. However, it is the responsibility of the product user to determine the suitability of Micron products for a specific application. While defective products will be replaced without charge if promptly returned, no liability is assumed beyond such replacement.

\* Trademark of Danaher Motion. DANAHER MOTION is registered in the U.S. Patent and Trademark Office and in other countries.

# NemaTRUE 90\* Size 23

## Right Angle Gearhead

English

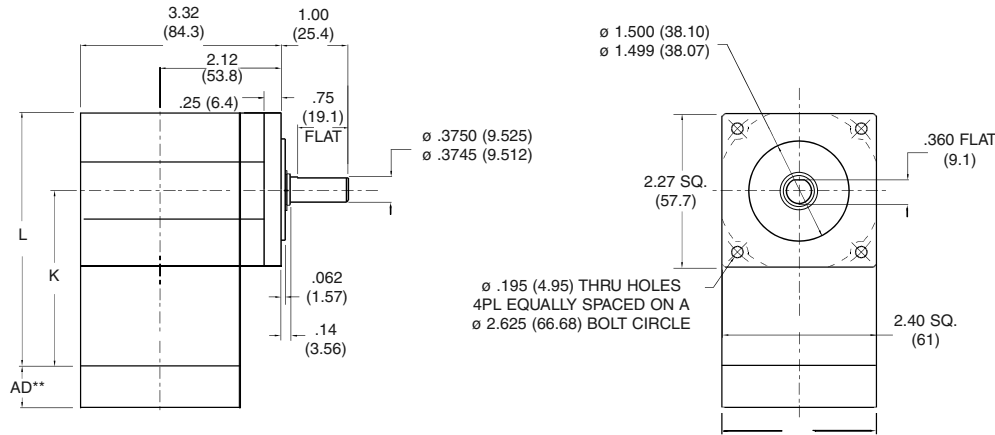

Ratio	Dimension 'K' in (mm)	Dimension 'L' in (mm)	Backlash (arc-min)	Weight lb (kg)	Efficiency
1:1 to 5:1P	3.11 (79)	4.31 (109.5)	13 max	3.0 (1.4)	95%
5:1T to 50:1	3.79 (96)	4.99 (127)	15 max	3.4 (1.5)	90%
60:1 to 500:1	4.48 (114)	5.68 (144)	15 max	3.8 (1.6)	85%

\*\* AD = Adapter length  
Adapter length will vary depending on motor.

(TABLE 1) PERFORMANCE SPECIFICATIONS

Part Number	Ratio <sup>1</sup>	5,000 HOUR LIFE			T <sub>peak</sub> in-lb (Nm)	10,000 HOUR LIFE			J in-lb-sec <sup>2</sup> x 10 <sup>4</sup> (kg-cm <sup>2</sup> )	Torsional Stiffness in-lb/arc-min (Nm/arc-min)
		T <sub>r</sub> (1000 rpm) in-lb (Nm)	T <sub>r</sub> (3000 rpm) in-lb (Nm)	T <sub>r</sub> (5000 rpm) in-lb (Nm)		T <sub>r</sub> (1000 rpm) in-lb (Nm)	T <sub>r</sub> (3000 rpm) in-lb (Nm)	T <sub>r</sub> (5000 rpm) in-lb (Nm)		
NTR23-001	1:1	59 (7)	54 (6)	49 (6)	195 (22)	54 (6)	50 (6)	45 (5)	7.01 (.79)	5.6 (0.6)
NTR23-002	2:1	130 (15)	118 (13)	107 (12)	360 (41)	120 (14)	109 (12)	99 (11)	3.59 (.41)	8.5 (1.0)
NTR23-003	3:1	83 (9)	75 (9)	68 (8)	270 (31)	76 (9)	70 (8)	63 (7)	3.09 (.35)	9.6 (1.1)
NTR23-004	4:1	61 (7)	56 (6)	50 (6)	238 (27)	56 (6)	51 (6)	46 (5)	2.87 (.32)	10.1 (1.1)
NTR23-005P	5:1P	50 (6)	46 (5)	41 (5)	180 (20)	46 (5)	42 (5)	38 (4)	2.81 (.32)	10.3 (1.2)
NTR23-005T	5:1T	179 (20)	153 (17)	138 (16)	366 (41)	175 (20)	132 (15)	112 (13)	3.69 (.42)	10.3 (1.2)
NTR23-006	6:1	153 (17)	130 (15)	126 (14)	366 (41)	149 (17)	120 (14)	116 (13)	3.67 (.41)	6.7 (0.8)
NTR23-009	9:1	97 (11)	83 (9)	80 (9)	289 (33)	95 (11)	76 (9)	74 (8)	3.08 (.35)	8.5 (1.0)
NTR23-010	10:1	157 (18)	144 (16)	130 (15)	366 (41)	155 (18)	138 (16)	120 (14)	3.48 (.39)	6.6 (0.7)
NTR23-012	12:1	72 (8)	61 (7)	59 (7)	252 (28)	70 (8)	56 (6)	55 (6)	2.95 (.33)	9.3 (1.1)
NTR23-015	15:1	100 (11)	91 (10)	83 (9)	297 (34)	99 (11)	88 (10)	76 (9)	2.89 (.33)	9.8 (1.1)
NTR23-020	20:1	74 (8)	67 (8)	61 (7)	366 (41)	73 (8)	64 (7)	56 (6)	2.76 (.31)	9.3 (1.0)
NTR23-025	25:1	60 (7)	55 (6)	50 (6)	198 (22)	60 (7)	53 (6)	46 (5)	2.71 (.31)	9.8 (1.1)
NTR23-030	30:1	102 (12)	98 (11)	94 (11)	305 (34)	102 (11)	96 (11)	90 (10)	2.83 (.32)	8.0 (0.9)
NTR23-040	40:1	75 (9)	72 (8)	69 (8)	263 (30)	75 (8)	71 (8)	67 (8)	2.69 (.30)	9.0 (1.0)
NTR23-050	50:1	62 (7)	59 (7)	57 (6)	203 (23)	61 (7)	58 (7)	55 (6)	2.64 (.30)	9.6 (1.1)
NTR23-060	60:1	163 (18)	161 (18)	158 (18)	366 (41)	163 (18)	160 (18)	157 (18)	3.68 (.42)	6.5 (0.7)
NTR23-075	75:1	104 (12)	102 (12)	100 (11)	311 (35)	103 (12)	101 (11)	99 (11)	2.95 (.33)	8.4 (0.9)
NTR23-090	90:1	104 (12)	102 (12)	101 (11)	313 (35)	103 (12)	102 (11)	100 (11)	3.09 (.35)	8.3 (0.9)
NTR23-100	100:1	163 (18)	162 (18)	161 (18)	366 (41)	163 (18)	161 (18)	160 (18)	3.50 (.40)	6.5 (0.7)
NTR23-120	120:1	76 (9)	75 (9)	74 (8)	270 (31)	76 (9)	75 (8)	73 (8)	2.96 (.33)	9.2 (1.0)
NTR23-125	125:1	63 (7)	62 (7)	60 (7)	207 (23)	62 (7)	61 (7)	60 (7)	2.76 (.31)	9.7 (1.1)
NTR23-150	150:1	104 (12)	103 (12)	102 (12)	316 (36)	104 (12)	103 (12)	102 (11)	2.91 (.33)	8.4 (0.9)
NTR23-200	200:1	164 (19)	163 (18)	162 (18)	366 (41)	164 (18)	163 (18)	162 (18)	3.43 (.39)	6.1 (0.7)
NTR23-250	250:1	63 (7)	62 (7)	62 (7)	207 (23)	63 (7)	62 (7)	61 (7)	2.72 (.31)	9.7 (1.1)
NTR23-300	300:1	104 (12)	104 (12)	103 (12)	319 (36)	104 (12)	104 (12)	103 (12)	2.84 (.32)	8.0 (0.9)
NTR23-400	400:1	77 (9)	76 (9)	76 (9)	274 (31)	77 (9)	76 (9)	76 (9)	2.71 (.31)	9.0 (1.0)
NTR23-500	500:1	63 (7)	63 (7)	62 (7)	207 (23)	63 (7)	63 (7)	62 (7)	2.66 (.30)	9.6 (1.1)

<sup>1</sup> Ratios are exact, higher ratios are also available, consult factory.  
T<sub>r</sub> = Rated output torque at rated speed for specific hours of life.  
J = Mass moment of inertia reflected to the input shaft (including pinion assembly)  
T<sub>peak</sub> = Allowable momentary peak torque for emergency stop or heavy shock loading.

**ELECTROMATE**  
Toll Free Phone (877) SERV098  
Toll Free Fax (877) SERV099  
www.electromate.com  
sales@electromate.com

# NemaTRUE 90\* Size 34

## Right Angle Gearhead

English

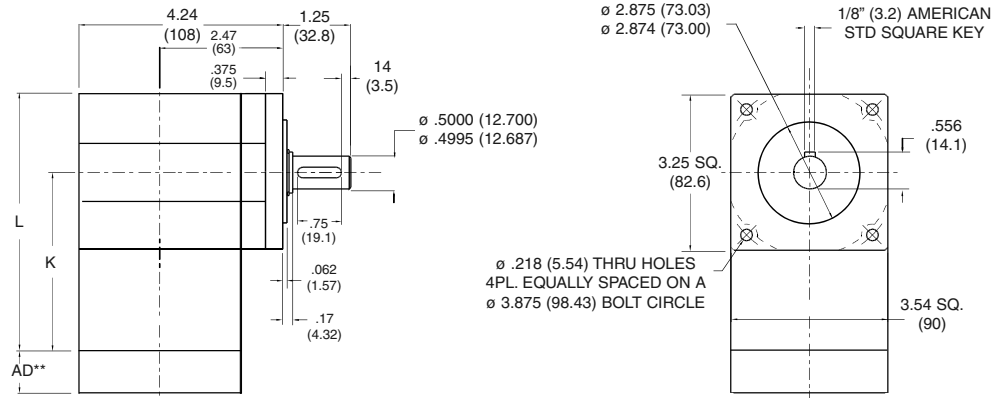

Ratio	Dimension 'K' in (mm)	Dimension 'L' in (mm)	Backlash (arc-min)	Weight lb (kg)	Efficiency
1:1 to 5:1P	3.99 (101)	5.76 (146)	13 max	6.0 (2.7)	95%
5:1T to 50:1	4.89 (124)	6.66 (169)	15 max	7.4 (3.4)	90%
60:1 to 500:1	5.79 (147)	7.56 (192)	15 max	8.8 (4.0)	85%

\*\* AD = Adapter length  
Adapter length will vary depending on motor.

(TABLE 1) PERFORMANCE SPECIFICATIONS

Part Number	Ratio <sup>1</sup>	5,000 HOUR LIFE			T <sub>peak</sub> in-lb (Nm)	10,000 HOUR LIFE			J in-lb-sec <sup>2</sup> x 10 <sup>4</sup> (kg-cm <sup>2</sup> )	Torsional Stiffness in-lb/arc-min (Nm/arc-min)
		T <sub>r</sub> (1000 rpm) in-lb (Nm)	T <sub>r</sub> (3000 rpm) in-lb (Nm)	T <sub>r</sub> (5000 rpm) in-lb (Nm)		T <sub>r</sub> (1000 rpm) in-lb (Nm)	T <sub>r</sub> (3000 rpm) in-lb (Nm)	T <sub>r</sub> (5000 rpm) in-lb (Nm)		
NTR34-001	1:1	168 (19)	153 (17)	139 (16)	493 (56)	155 (18)	142 (16)	128 (14)	27.5 (3.11)	12.6 (1.4)
NTR34-002	2:1	381 (43)	348 (39)	315 (36)	1113 (126)	352 (40)	321 (36)	291 (33)	14.1 (1.59)	19.1 (2.2)
NTR34-003	3:1	251 (28)	229 (26)	207 (23)	905 (102)	232 (26)	212 (24)	192 (22)	12.1 (1.37)	21.5 (2.4)
NTR34-004	4:1	192 (22)	176 (20)	159 (18)	695 (79)	178 (20)	162 (18)	147 (17)	11.2 (1.27)	22.6 (2.5)
NTR34-005P	5:1P	142 (16)	129 (15)	117 (13)	581 (66)	131 (15)	119 (13)	108 (12)	11.0 (1.25)	23.1 (2.6)
NTR34-005T	5:1T	508 (57)	432 (49)	420 (47)	1113 (126)	497 (56)	399 (45)	387 (44)	14.5 (1.64)	23.1 (2.6)
NTR34-006	6:1	448 (51)	381 (43)	370 (42)	1113 (126)	439 (50)	352 (40)	342 (39)	14.4 (1.63)	15.0 (1.7)
NTR34-009	9:1	296 (33)	251 (28)	244 (28)	986 (111)	289 (33)	232 (26)	225 (25)	12.1 (1.37)	19.0 (2.1)
NTR34-010	10:1	462 (52)	422 (48)	381 (43)	1113 (126)	456 (52)	404 (46)	352 (40)	13.7 (1.54)	14.8 (1.7)
NTR34-012	12:1	226 (26)	192 (22)	187 (21)	752 (85)	221 (25)	178 (20)	173 (19)	11.6 (1.31)	20.9 (2.4)
NTR34-015	15:1	305 (34)	278 (31)	251 (28)	1018 (115)	301 (34)	266 (30)	232 (26)	11.3 (1.28)	21.9 (2.5)
NTR34-020	20:1	233 (26)	213 (24)	192 (22)	1113 (126)	230 (26)	204 (23)	178 (20)	10.8 (1.22)	20.8 (2.4)
NTR34-025	25:1	172 (19)	157 (18)	142 (16)	635 (72)	169 (19)	150 (17)	131 (15)	10.6 (1.20)	21.9 (2.5)
NTR34-030	30:1	311 (35)	298 (34)	285 (32)	1045 (118)	309 (35)	292 (33)	275 (31)	11.1 (1.25)	17.9 (2.0)
NTR34-040	40:1	238 (27)	228 (26)	218 (25)	792 (89)	237 (27)	224 (25)	210 (24)	10.6 (1.19)	20.2 (2.3)
NTR34-050	50:1	175 (20)	168 (19)	160 (18)	653 (74)	174 (20)	165 (19)	155 (18)	10.4 (1.17)	21.4 (2.4)
NTR34-060	60:1	479 (54)	472 (53)	465 (53)	1113 (126)	478 (54)	469 (53)	460 (52)	14.4 (1.63)	14.5 (1.6)
NTR34-075	75:1	315 (36)	310 (35)	305 (34)	1080 (122)	314 (36)	308 (35)	301 (34)	11.6 (1.31)	18.7 (2.1)
NTR34-090	90:1	316 (36)	311 (35)	307 (35)	1085 (123)	315 (36)	309 (35)	304 (34)	12.1 (1.37)	18.6 (2.1)
NTR34-100	100:1	480 (54)	476 (54)	472 (53)	1113 (126)	479 (54)	474 (54)	469 (53)	13.7 (1.55)	14.6 (1.7)
NTR34-120	120:1	242 (27)	238 (27)	235 (27)	817 (92)	241 (27)	237 (27)	232 (26)	11.6 (1.31)	20.7 (2.3)
NTR34-125	125:1	178 (20)	175 (20)	172 (19)	666 (75)	177 (20)	173 (20)	169 (19)	10.8 (1.23)	21.8 (2.5)
NTR34-150	150:1	317 (36)	314 (35)	311 (35)	1096 (124)	316 (36)	313 (35)	309 (35)	11.4 (1.29)	18.7 (2.1)
NTR34-200	200:1	481 (54)	479 (54)	477 (54)	1113 (126)	481 (54)	478 (54)	475 (54)	13.5 (1.52)	13.6 (1.5)
NTR34-250	250:1	178 (20)	177 (20)	175 (20)	675 (76)	178 (20)	176 (20)	174 (20)	10.7 (1.21)	21.8 (2.5)
NTR34-300	300:1	317 (36)	316 (36)	315 (36)	1107 (125)	317 (36)	315 (36)	314 (35)	11.1 (1.26)	17.9 (2.0)
NTR34-400	400:1	243 (27)	242 (27)	241 (27)	832 (94)	243 (27)	241 (27)	240 (27)	10.6 (1.20)	20.2 (2.3)
NTR34-500	500:1	179 (20)	178 (20)	177 (20)	680 (77)	179 (20)	178 (20)	177 (20)	10.4 (1.18)	21.4 (2.4)

<sup>1</sup> Ratios are exact, higher ratios are also available, consult factory.

T<sub>r</sub> = Rated output torque at rated speed for specific hours of life.

J = Mass moment of inertia reflected to the input shaft (including pinion assembly)

T<sub>peak</sub> = Allowable momentary peak torque for emergency stop or heavy shock loading.

**ELECTROMATE**  
Toll Free Phone (877) SERV098  
Toll Free Fax (877) SERV099  
www.electromate.com  
sales@electromate.com



©2003 Danaher Motion. Printed in the U.S.A. The specifications in this publication are believed to be accurate and reliable. However, it is the responsibility of the product user to determine the suitability of Micron products for a specific application. While defective products will be replaced without charge if promptly returned, no liability is assumed beyond such replacement.

# NemaTRUE 90\* Size 42

## Right Angle Gearhead

English

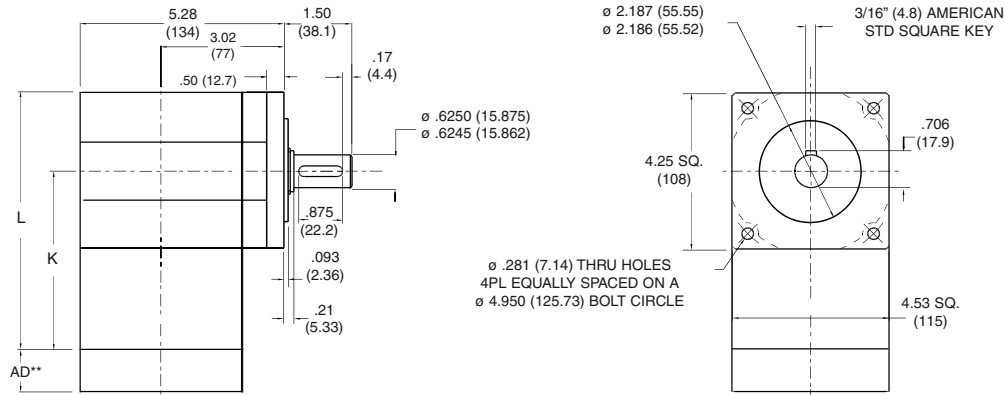

Ratio	Dimension 'K' in (mm)	Dimension 'L' in (mm)	Backlash (arc-min)	Weight lb (kg)	Efficiency
1:1 to 5:1P	5.40 (137)	7.67 (195)	13 max	12 (5.4)	95%
5:1T to 50:1	6.63 (168.4)	8.90 (226)	15 max	14.8 (6.7)	90%
60:1 to 500:1	7.87 (200)	10.13 (257)	15 max	17.6 (8.0)	85%

\*\* AD = Adapter length  
Adapter length will vary depending on motor.

(TABLE 1) PERFORMANCE SPECIFICATIONS

Part Number	Ratio <sup>1</sup>	5,000 HOUR LIFE			T <sub>peak</sub> in-lb (Nm)	10,000 HOUR LIFE			J in-lb-sec <sup>2</sup> x 10 <sup>-4</sup> (kg-cm <sup>2</sup> )	Torsional Stiffness in-lb/arc-min (Nm/arc-min)
		T <sub>r</sub> (1000 rpm) in-lb (Nm)	T <sub>r</sub> (3000 rpm) in-lb (Nm)	T <sub>r</sub> (5000 rpm) in-lb (Nm)		T <sub>r</sub> (1000 rpm) in-lb (Nm)	T <sub>r</sub> (3000 rpm) in-lb (Nm)	T <sub>r</sub> (5000 rpm) in-lb (Nm)		
NTR42-001	1:1	496 (56)	452 (51)	409 (46)	1620 (183)	458 (52)	418 (47)	378 (43)	46.7 (5.28)	15.0 (1.7)
NTR42-002	2:1	885 (100)	808 (91)	730 (83)	2255 (255)	817 (92)	746 (84)	674 (76)	23.9 (2.71)	24.7 (2.8)
NTR42-003	3:1	687 (78)	627 (71)	567 (64)	2039 (230)	635 (72)	579 (65)	524 (59)	20.6 (2.33)	28.0 (3.2)
NTR42-004	4:1	458 (52)	418 (47)	378 (43)	1584 (179)	423 (48)	386 (44)	349 (39)	19.1 (2.16)	29.4 (3.3)
NTR42-005P	5:1P	343 (39)	313 (35)	283 (32)	1305 (147)	317 (36)	289 (33)	261 (30)	18.8 (2.12)	30.0 (3.4)
NTR42-005T	5:1T	1346 (152)	1117 (126)	958 (108)	2255 (255)	1262 (143)	907 (102)	778 (88)	24.6 (2.78)	30.0 (3.4)
NTR42-006	6:1	1041 (118)	885 (100)	859 (97)	2255 (255)	1018 (115)	817 (92)	794 (90)	24.5 (2.77)	20.1 (2.3)
NTR42-009	9:1	808 (91)	687 (78)	667 (75)	2241 (253)	791 (89)	635 (72)	616 (70)	20.5 (2.32)	25.1 (2.8)
NTR42-010	10:1	1072 (121)	979 (111)	885 (100)	2255 (255)	1059 (120)	938 (106)	817 (92)	23.2 (2.63)	20.1 (2.3)
NTR42-012	12:1	538 (61)	458 (52)	444 (50)	1728 (195)	526 (59)	423 (48)	410 (46)	19.6 (2.22)	27.5 (3.1)
NTR42-015	15:1	832 (94)	760 (86)	687 (78)	2255 (255)	822 (93)	728 (82)	635 (72)	19.3 (2.18)	28.8 (3.3)
NTR42-020	20:1	554 (63)	506 (57)	458 (52)	2255 (255)	547 (62)	485 (55)	423 (48)	18.4 (2.08)	27.5 (3.1)
NTR42-025	25:1	416 (47)	379 (43)	343 (39)	1458 (165)	410 (46)	364 (41)	317 (36)	18.0 (2.04)	28.8 (3.2)
NTR42-030	30:1	851 (96)	814 (92)	778 (88)	2255 (255)	845 (96)	798 (90)	752 (85)	18.9 (2.13)	24.6 (2.8)
NTR42-040	40:1	566 (64)	542 (61)	518 (59)	1836 (207)	563 (64)	532 (60)	500 (57)	18.0 (2.03)	27.2 (3.1)
NTR42-050	50:1	425 (48)	407 (46)	388 (44)	1499 (169)	422 (48)	399 (45)	375 (42)	17.6 (1.99)	28.5 (3.2)
NTR42-060	60:1	1111 (126)	1095 (124)	1080 (122)	2255 (255)	1109 (125)	1089 (123)	1069 (121)	24.6 (2.78)	19.7 (2.2)
NTR42-075	75:1	861 (97)	847 (96)	832 (94)	2255 (255)	859 (97)	841 (95)	822 (93)	19.7 (2.22)	25.0 (2.8)
NTR42-090	90:1	863 (97)	851 (96)	838 (95)	2255 (255)	861 (97)	845 (96)	830 (94)	20.6 (2.33)	24.8 (2.8)
NTR42-100	100:1	1114 (126)	1105 (125)	1095 (124)	2255 (255)	1113 (126)	1101 (124)	1089 (123)	23.3 (2.64)	19.9 (2.2)
NTR42-120	120:1	574 (65)	566 (64)	558 (63)	1897 (214)	573 (65)	563 (64)	552 (62)	19.7 (2.23)	27.3 (3.1)
NTR42-125	125:1	430 (49)	423 (48)	416 (47)	1539 (174)	429 (48)	420 (47)	410 (46)	18.4 (2.08)	28.7 (3.2)
NTR42-150	150:1	865 (98)	858 (97)	851 (96)	2255 (255)	864 (98)	855 (97)	845 (96)	19.4 (2.19)	25.0 (2.8)
NTR42-200	200:1	1116 (126)	1112 (126)	1107 (125)	2255 (255)	1116 (126)	1110 (125)	1104 (125)	22.9 (2.59)	19.4 (2.2)
NTR42-250	250:1	432 (49)	428 (48)	425 (48)	1562 (176)	431 (49)	427 (48)	422 (48)	18.1 (2.05)	28.7 (3.2)
NTR42-300	300:1	867 (98)	863 (98)	860 (97)	2255 (255)	866 (98)	862 (97)	857 (97)	18.9 (2.14)	24.6 (2.8)
NTR42-400	400:1	577 (65)	575 (65)	572 (65)	1944 (220)	577 (65)	574 (65)	571 (64)	18.1 (2.04)	27.1 (3.1)
NTR42-500	500:1	433 (49)	431 (49)	429 (48)	1580 (178)	433 (49)	430 (49)	428 (48)	17.7 (2.00)	28.5 (3.2)

<sup>1</sup> Ratios are exact, higher ratios are also available, consult factory.

T<sub>r</sub> = Rated output torque at rated speed for specific hours of life.

J = Mass moment of inertia reflected to the input shaft (including pinion assembly)

T<sub>peak</sub> = Allowable momentary peak torque for emergency stop or heavy shock loading.

**ELECTROMATE**  
Toll Free Phone (877) SERV098  
Toll Free Fax (877) SERV099  
www.electromate.com  
sales@electromate.com

## Radial and Axial Load Ratings (Table 2)

These graphs display the allowable radial load at a given distance (X) from the mounting surface based on an  $L_{10}$  life of 10,000 hours for the mean output speed,

$$n_{mout} = \frac{n_m}{i}, \text{ as described on page 10.}$$

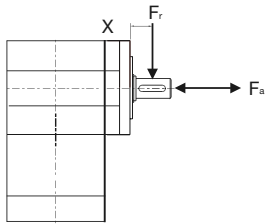

**NTR23 Radial Load Ratings**

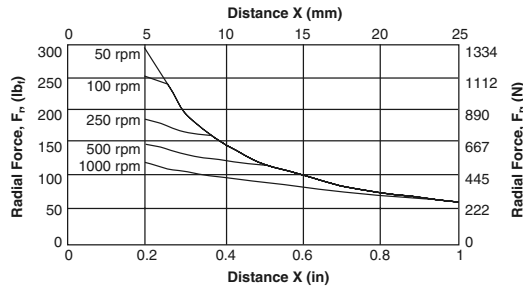

**NTR23 Axial Load Ratings**

Speed (rpm)	Axial Load, $F_a$ (lb <sub>f</sub> )	Axial Load, $F_a$ (N)
50	250	(1110)
100	200	(890)
250	150	(670)
500	120	(530)
1000	90	(400)

**NTR34 Radial Load Ratings**

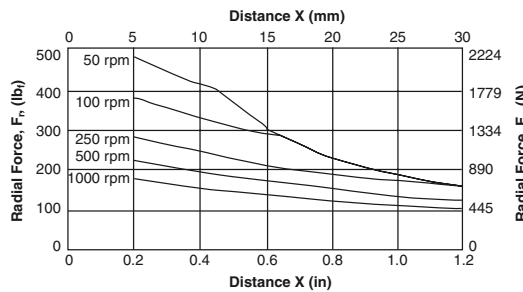

**NTR34 Axial Load Ratings**

Speed (rpm)	Axial Load, $F_a$ (lb <sub>f</sub> )	Axial Load, $F_a$ (N)
50	340	(1510)
100	270	(1200)
250	200	(890)
500	160	(710)
1000	130	(580)

**NTR42 Radial Load Ratings**

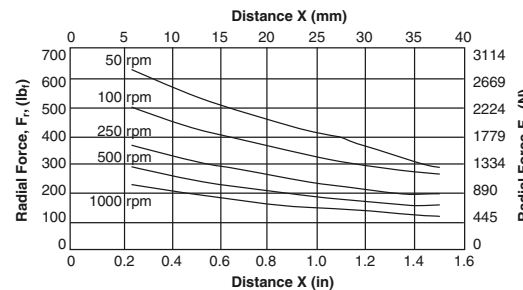

**NTR42 Axial Load Ratings**

Speed (rpm)	Axial Load, $F_a$ (lb <sub>f</sub> )	Axial Load, $F_a$ (N)
50	460	(2050)
100	370	(1650)
250	270	(1200)
500	210	(930)
1000	170	(760)

Sold & Serviced By:  
**ELECTROMATE**  
 Toll Free Phone (877) SERV098  
 Toll Free Fax (877) SERV099  
 www.electromate.com  
 sales@electromate.com

# Mounting Tools

## Micrometer Adjustable Torque Wrench Series



### Torque Wrench Ordering Information

To ensure that the proper torque is applied to the gearhead pinion assembly, Danaher Motion offers a complete line of easy to use torque wrenches. To order a torque wrench, ask for the corresponding part number along with your gearhead order.

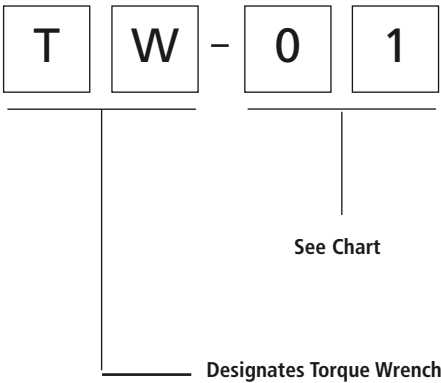

Gearhead Model	Gearhead Frame Size	Torque Wrench Part Number
NemaTRUE*	23 / 60	TW-060
	34 / 90	TW-090
	42 / 115	TW-115
NemaTRUE 90*	23	TW-060
	34	TW-090
	42	TW-115
DuraTRUE* DuraTRUE 90*	60	TW-060
	90	TW-090
	115	TW-115
UltraTRUE* UltraTRUE 90*	142	TW-142
	60	TW-006
	75	TW-075
	90	TW-075
	100	TW-010
	115	TW010
	140	TW-014
EverTRUE*	180	TW-018
	100	TW-010
	140	TW-014
EQ*	23 / 60	TW-060

Sold & Serviced By:

ELECTROMATE

Toll Free Phone (877) SERV098  
Toll Free Fax (877) SERV099  
www.electromate.com  
sales@electromate.com



# True Planetary\* Gearheads offer. . .

- **High Torque to Size Ratio** - allows compact design
- **Low Backlash** - eliminates positioning errors due to lost motion
- **Inertia Matching** - keeps servo system stable and in control
- **High Rigidity** - optimizes system response
- **Self Re-lubrication** - eliminates costly maintenance and downtime
- **High Radial Load Capacity** - mount pulleys and pinions directly on the output shaft



UltraTRUE\* output cage assembly

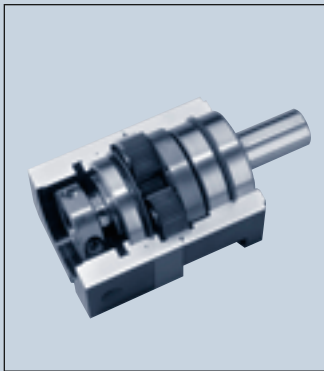

DuraTRUE\* in-line planetary gearhead

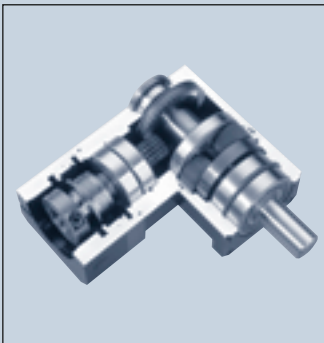

DuraTRUE 90\* right angle planetary gearhead

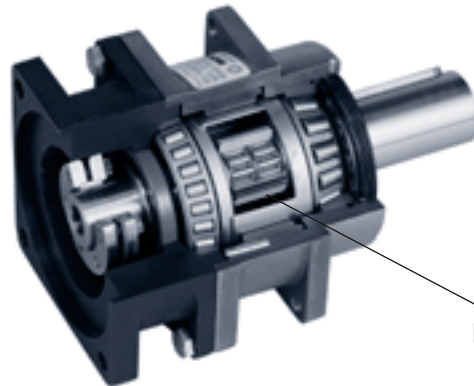

Planetary Gearing

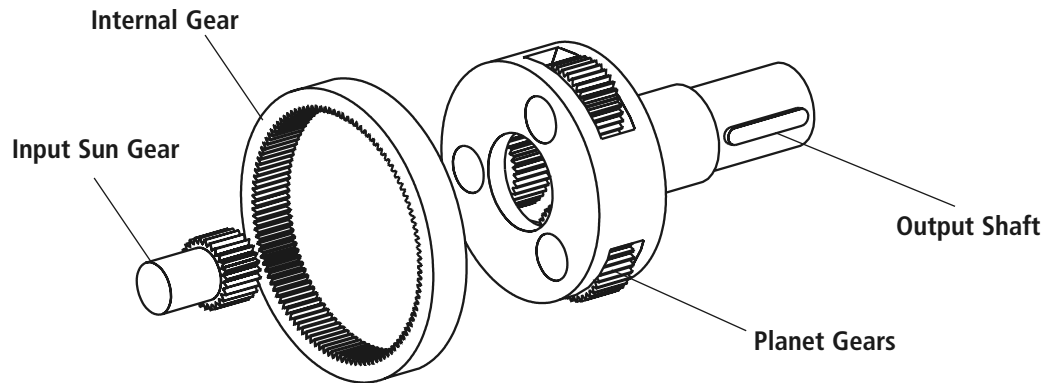

	Gearhead						
Product Feature	NemaTRUE*	NemaTRUE 90*	DuraTRUE*	DuraTRUE 90*	UltraTRUE*	UltraTRUE 90*	EverTRUE*
True Planetary gearing	●	●	●	●	●	●	●

Sold & Distributed by:  
**ELECTROMATE**  
 Toll Free Phone (877) SERV098  
 Toll Free Fax (877) SERV099  
[www.electromate.com](http://www.electromate.com)  
[sales@electromate.com](mailto:sales@electromate.com)



# Helical Crowned True Planetary\* Gearing offers.....

- High Torque Capacity
- Low Backlash
- Smooth Operation
- Greater Load Sharing
- Whisper Quiet



Output housing and helical internal gear are machined from a single piece of high strength steel

Helical gears are known for their quiet and smooth operation along with their ability to transmit higher loads than spur gears. Both of these features of helical gearing result from the improved contact ratio (effective teeth in mesh) over spur gears. Crowning is a modification to the gear tooth profile which optimizes gear mesh alignment. It also enhances distribution of loading on the tooth flank, thereby reducing high stress regions which can result in surface pitting.

### Spur vs. Helical Gearing

Typical contact ratio is 1.5 for spur gearing.

Contact ratio for equivalent helical gear is 3.3... **more than double the contact ratio.**

The Contact ratio is defined as the number of teeth in mesh at any given time. The higher the contact ratio, the higher the torque rating of the gearing. **Helical gearing has more than 2X the contact ratio of spur gearing.**

### Crowned vs. Non-crowned

Non-crowned: High stress region

Crowned: Even load distribution

Crowning optimizes the gear mesh alignment within a gear train to increase the torque capacity and reduce noise. It also enhances load distribution on the tooth flank to reduce high stress regions.

UltraTRUE\* in-line planetary gearhead

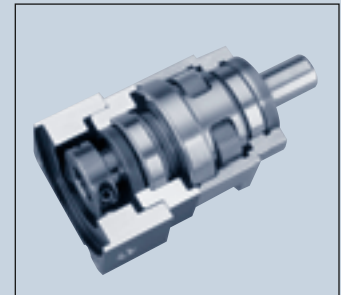

Planetary gearheads are often selected for high precision motion control applications which require a high torque to volume ratio, high torsional stiffness and low backlash. Until now, these attributes have been sufficient to meet the requirements of the market. Danaher Motion has designed a high torque, whisper quiet helical gearhead to meet the recent improvements in servo motor technology.

Danaher Motion engineers accomplished this by combining the positive attributes of gear crowning and helical gearing with the planetary construction to create the smoothest operating gearhead on the market.



UltraTRUE 90\* right angle planetary gearhead

	Gearhead						
Product Feature	NemaTRUE*	NemaTRUE 90*	DuraTRUE*	DuraTRUE 90*	UltraTRUE*	UltraTRUE 90*	EverTRUE*
Helical crowned True Planetary gearing					●	●	

Sold & Serviced By:  
**ELECTROMATE**  
 Toll Free Phone (877) SERV098  
 Toll Free Fax (877) SERV099  
 www.electromate.com  
 sales@electromate.com

\* Trademark of Danaher Motion. DANAHER MOTION is registered in the U.S. Patent and Trademark Office and in other countries.

# PowerTRUE\* Right Angle Gearheads offer.....

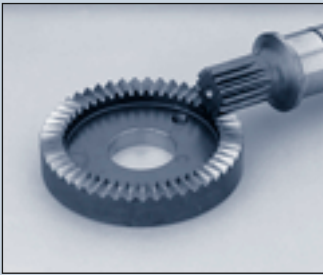

PowerTRUE\* right angle gearset

Right angle gear meshes are typically limited to ratios from 1:1 to 3:1 when using standard bevel gears. Compared to these designs, the PowerTRUE 90 gear increases the ratio range to 5:1.

The key to higher torque density is a unique tooth design, created by complex machining made practical with advanced CNC equipment and software. In the design, multiple teeth in the face gear simultaneously mesh with a standard involute pinion. The continuous tooth engagement yields a high contact ratio between the gear and the pinion, boosting torques to new levels and efficiency to 98%.

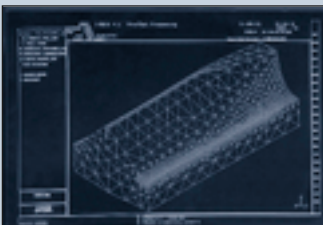

Advanced software enables stress analysis of PowerTRUE tooth profile

- Lower backlash accomplished through single axis mesh adjustment
- A compact right angle design utilizing a high-tech face gear
- Whisper quiet operation due to high contact ratio
- Mesh ratios from 1:1 to 5:1
- 98% efficiency

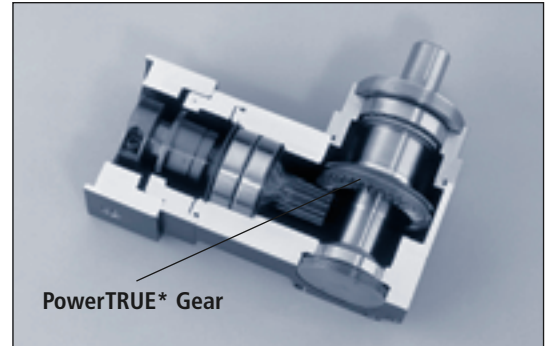

PowerTRUE\* Gear



CNC Machining of a PowerTRUE\* right angle gear

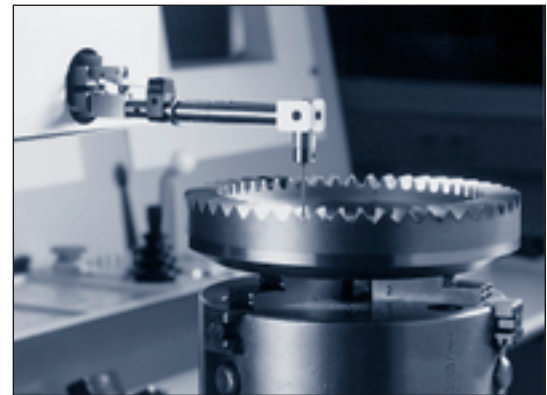

Computerized mapping of gear tooth profile

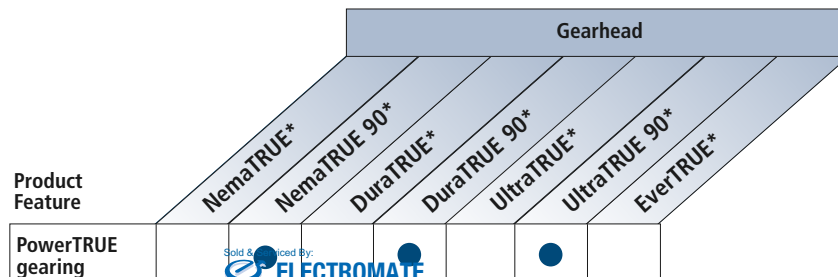

Sold & serviced by:  
**ELECTROMATE**  
 Toll Free Phone (877) SERV098  
 Toll Free Fax (877) SERV099  
[www.electromate.com](http://www.electromate.com)  
[sales@electromate.com](mailto:sales@electromate.com)

# RediMount\* Motor Mounting System



Exploded view of RediMount mounting system

## Mounting Instructions

1- Slide the provided sleeve into the hub and align the slot in the bushing with the slot in the hub.

2- Set the motor on a work surface or hold fixture with the output shaft facing straight up. If there is a key on the motor, remove it and align the keyway with the slot in the hub. Slide the gearhead down onto the motor shaft.

3- Rotate the hub to align the input housing access holes with the hub clamping bolts.

4 - Using a torque wrench tighten the hub bolts to the pre-torque value indicated in the table.

5 - Bolt the motor to the gearhead with the bolts provided.

6 - Gradually tighten the hub bolts in three steps, increasing the torque each time until reaching the final tightening torque in the table.



Close-up view of the bearing system and hub sleeve which accommodates various motor shaft diameters.

- **Self-aligning hub** - Maintains concentricity between motor shaft and gearhead
- **Pre-installed pinion** - Eliminates pinion setting procedure
- **Modular design** - Allows gearhead and input housing to be stocked separately
- **Flexibility** - Allows easy changeover to alternate motors
- **Interchangeability** - Same RediMount system is used throughout 7 product lines

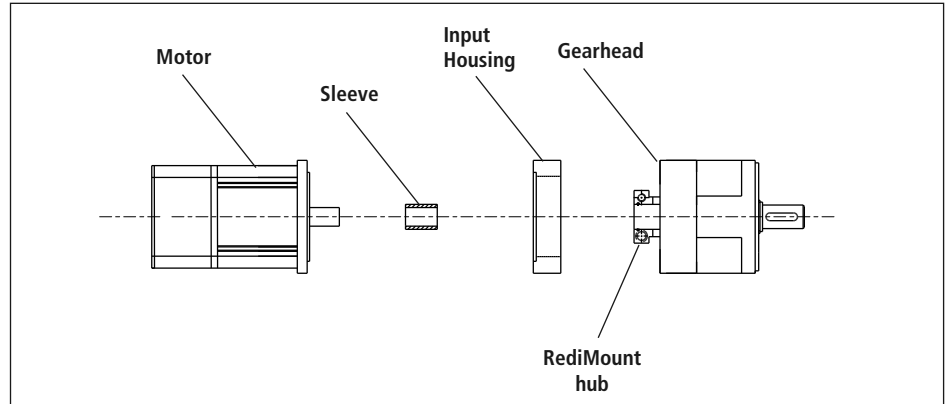

Hub Bolt Tightening Torques					
Gearhead Model	Gearhead Frame Size	Pre-Tightening Torque		Final Tightening Torque	
		in-lb	Nm	in-lb	Nm
NemaTRUE* NemaTRUE 90*	23	2	.2	39	4.4
	34	4	.4	76	8.5
	42	16	1.8	316	36.0
DuraTRUE* DuraTRUE 90*	60	2	.2	39	4.4
	90	4	.4	76	8.5
	115	16	1.8	316	36.0
	142	32	3.6	636	72.0
UltraTRUE* UltraTRUE 90*	60	2	.2	39	4.4
	75/90	4	.4	76	8.5
	10/115	16	1.8	316	36.0
	140	32	3.6	636	72.0
	180	55	6.3	1104	125.0

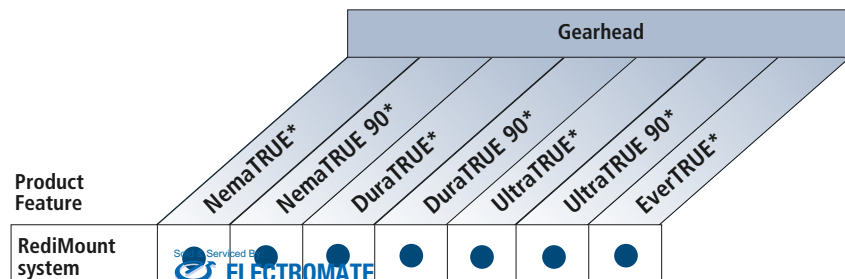

Product Feature  
RediMount system

Service by  
**ELECTROMATE**  
Toll Free Phone (877) SERV098  
Toll Free Fax (877) SERV099  
www.electromate.com  
sales@electromate.com

**Step 1:** Select the required precision class and gearhead configuration (in-line or right angle).

**Step 2:** Select the proper gearhead using exact or general method.

For continuous duty applications, please contact Applications Engineering.

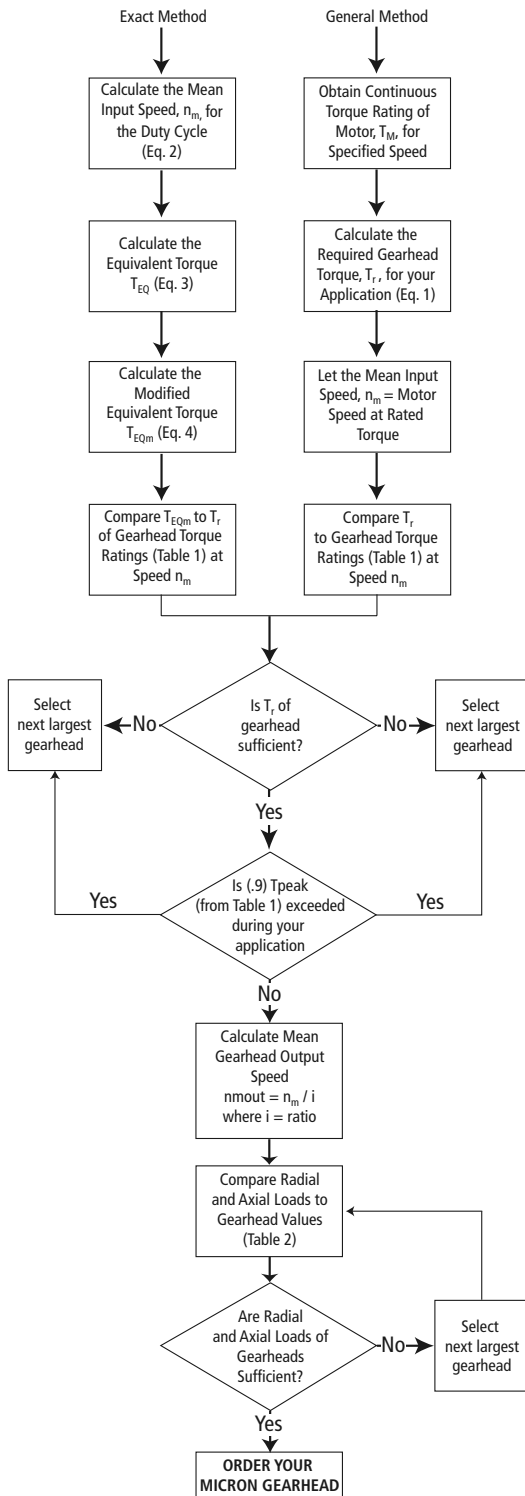

**General Method:**

**Required Gearhead Torque (T<sub>r</sub>)**

(1)  $T_r = T_M^* \times i \times e$

where:  $T_M^*$  = continuous torque of motor  
 $i$  = gearhead ratio  
 $e$  = efficiency of gearhead

\* Since many motors are capable of exceeding their continuous torque rating for extended lengths of time, the value for  $T_M$  will only provide a starting point for gearhead selection. Only use the general method if the continuous motor rating is not exceeded in the application.

**Exact Method**

**Motion Profile**

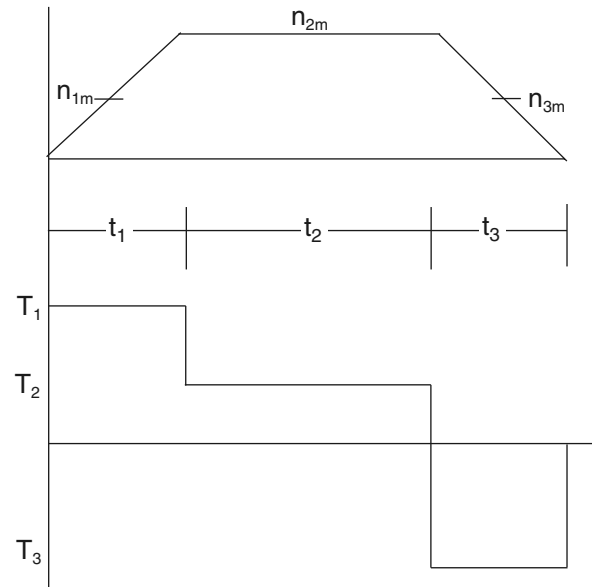

$t_n$  = time period n  
 $n_{nm}$  = mean speed during time period  $t_n$   
 $T_n$  = torque during time period  $t_n$

**Mean input speed (n<sub>m</sub>)**

(2)  $n_m = \frac{n_{1m}t_1 + n_{2m}t_2 + n_{3m}t_3 + \dots + n_{nm}t_n}{t_t}$

where  $t_t = t_1 + t_2 + t_3 + \dots + t_n$

**Equivalent torque (T<sub>EQ</sub>)**

(3)  $T_{EQ} = \sqrt[8.7]{T_1^{8.7} \frac{n_{1m}t_1}{n_m t_t} + T_2^{8.7} \frac{n_{2m}t_2}{n_m t_t} + T_3^{8.7} \frac{n_{3m}t_3}{n_m t_t} + \dots + T_n^{8.7} \frac{n_{nm}t_n}{n_m t_t}}$

**Modified equivalent torque (T<sub>EQm</sub>)**

(4)  $T_{EQm} = T_{EQ} \cdot Q$

Q	# of cycles/hr
1	>0
.9	>1000
.7	>2500
.5	>5000

where Q is:

Sold & Serviced By:  
**ELECTROMATE**  
 Toll Free Phone (877) SERV098  
 Toll Free Fax (877) SERV099  
 www.electromate.com  
 sales@electromate.com