

# Digital Servo Amplifier S700



## Safety First!

The challenges faced by today's mechanical and process engineers include an increasing demand for a broader range of products and services, higher productivity, as well as increased supply availability and reliability. With its new S700 servo amplifier, Kollmorgen is now able to offer a product that is definitely up to these challenges.

The S700, which is based on the SERVOSTAR® 300 architecture and features the same kind of processor, is a fully digital servo amplifier that is ideal for complex drive tasks. You also have the option of using an MMC memory card, which enables parameter records and firmware to be backed up and copied extremely quickly and easily in the field.

In light of the fact that a growing number of engineers are moving towards Ethernet based communications such as EtherCAT and SynqNet, Kollmorgen has geared the S700 to the future by integrated an Ethernet connection into the new drive. The S700's onboard interface means that customers no longer have to rely on additional expansion cards for this kind of compatibility.

The S700 integrates a Safe Torque Off function. A digital input disables the amplifier's power output stage, thereby implementing the Safe Torque Off function (safe stop). Advanced safety functions such as „Safely Limited Speed“ and „Safe Stop 2“ are implemented by means of a safety expansion card.



### The advantages for you

- |   |  |
|---|--|
| <ul style="list-style-type: none"> <li>• <b>Increased productivity</b></li> </ul>         | <ul style="list-style-type: none"> <li>• High-speed current, speed and position control results in higher machine cycle rates</li> <li>• Safety functions to IEC 61800 increase machine availability</li> </ul>  |
| <ul style="list-style-type: none"> <li>• <b>Fewer types need to be stocked</b></li> </ul> | <ul style="list-style-type: none"> <li>• Multi-interface facilitates connection to all standard controllers</li> <li>• Multi-feedback feature compatible with all common feedback systems</li> <li>• Asynchronous Motors can also be operated</li> </ul>                                     |
| <ul style="list-style-type: none"> <li>• <b>Smaller switchgear cabinets</b></li> </ul>    | <ul style="list-style-type: none"> <li>• EMV-filter on board</li> <li>• Integrated power supply and brake resistor</li> <li>• Mains choke is not necessary</li> </ul>  |
| <ul style="list-style-type: none"> <li>• <b>Faster startup</b></li> </ul>                 | <ul style="list-style-type: none"> <li>• Memory card for parameter &amp; firmware updates</li> <li>• All connections via connectors</li> <li>• Autotuning</li> </ul>   |
| <ul style="list-style-type: none"> <li>• <b>Lower system costs</b></li> </ul>             | <ul style="list-style-type: none"> <li>• Ethernet on board means real time fieldbuses like EtherCat without additional hardware</li> <li>• IEC1131 structured text</li> <li>• A single device for all application variants</li> <li>• Flexible interfaces make configuration easy</li> </ul> |

## Applications

With its new S700 servo amplifier, Kollmorgen is able to meet the user demand for a high level of safety, flexible integration and faster throughput times.

Within this context, the versatile communication strategy, user-friendly interface and machine safety concepts all have an important part to play. The optimized control

response results in improved performance and dynamics. The S700 is the perfect choice for an extremely wide range of automation environments including, for example, semiconductor production, packaging industry, medical engineering, woodworking, and plastics processing applications.

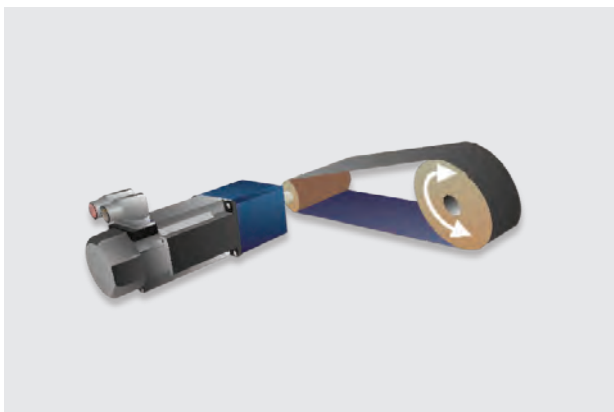

Belt drive

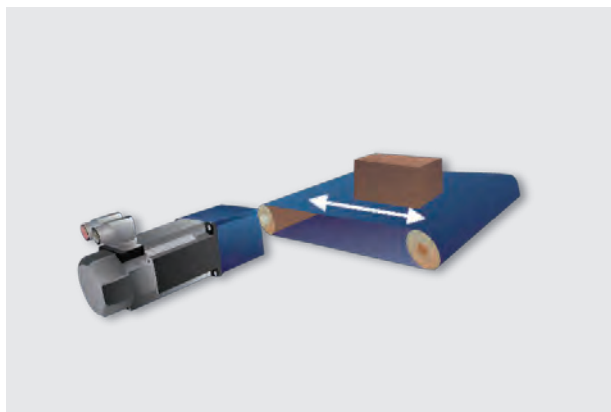

Conveyor belt

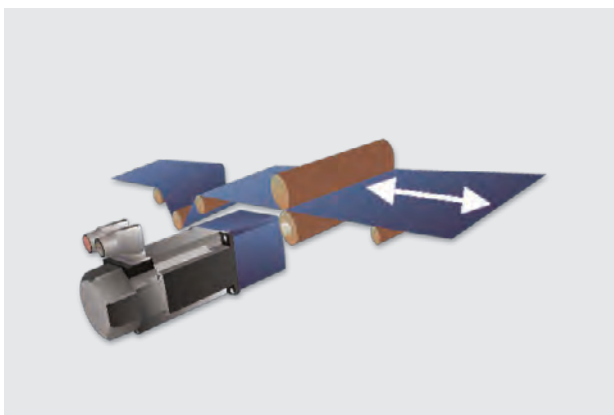

Endless conveyor

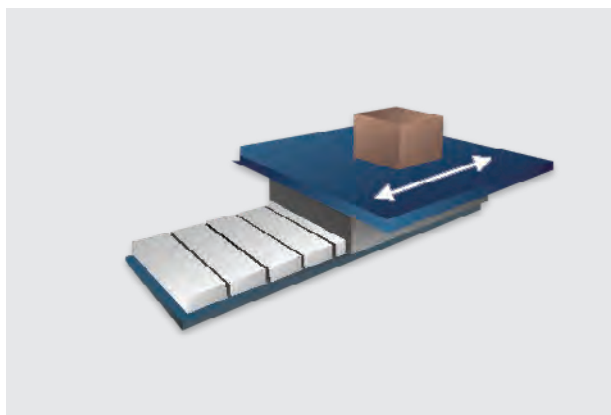

Direct drive: linear

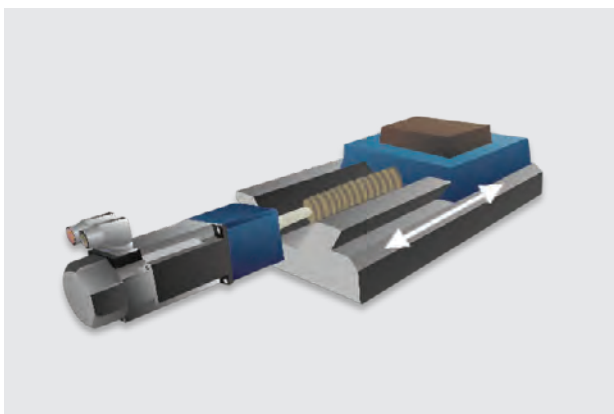

Spindle drive

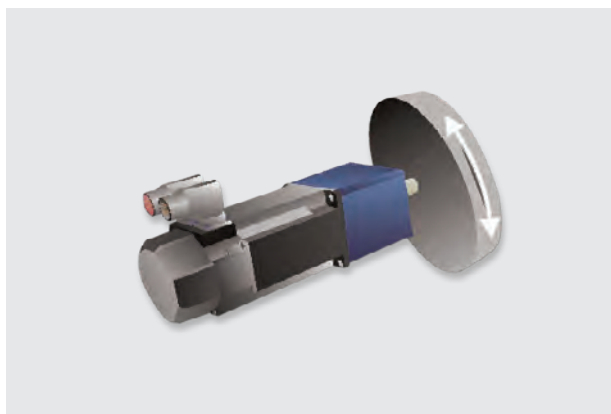

Disk

## Technical Data

Rated data	DIM	S701	S703	S706	S712	S7120P	S724	S7240P	S748	S772
Rated line voltage	V~	3 x 208V <sub>-10%</sub> ... 3 x 480V <sub>+10%</sub> , 50/60 Hz								
Rated line power for S1 operation	kVA	1,1	2,2	4,5	9	9	18	18	35	50
Auxiliary supply	V=	24								
Rated DC-link voltage	V=	290-675								
Rated output current (rms value)										
- At 3 x 208 V	Arms	2,5	5	6	12	12	24	24	48	72
- At 3 x 230 V	Arms	2	4	6	12	12	24	24	48	72
- At 3 x 400 V	Arms	1,5	3	6	12	12	24	24	48	72
- At 3 x 480 V	Arms	1,5	3	6	12	12	24	24	48	70
Peak output current (rms value)	Arms	4,5	9	18	24	30	48	72	96	140

## Dimensions

**S701-S712**



**S724**



**S748 / S772**



Dimensions	DIM	S701	S703	S706	S712	S7120P	S724	S7240P	S748	S772
(H) Height incl. Fan	mm	345					348		385	
(W) Width	mm	70					100		190	
(D) Depth incl. Connector	mm	243							285	

## Multi-feedback

The S700 can read data from a wide range of feedback systems and evaluate up to three of them in parallel. This feature ensures a high level of flexibility where integration of the S700 into different applications is concerned. Control without a feedback system is also supported, e.g. in the case of asynchronous motors.

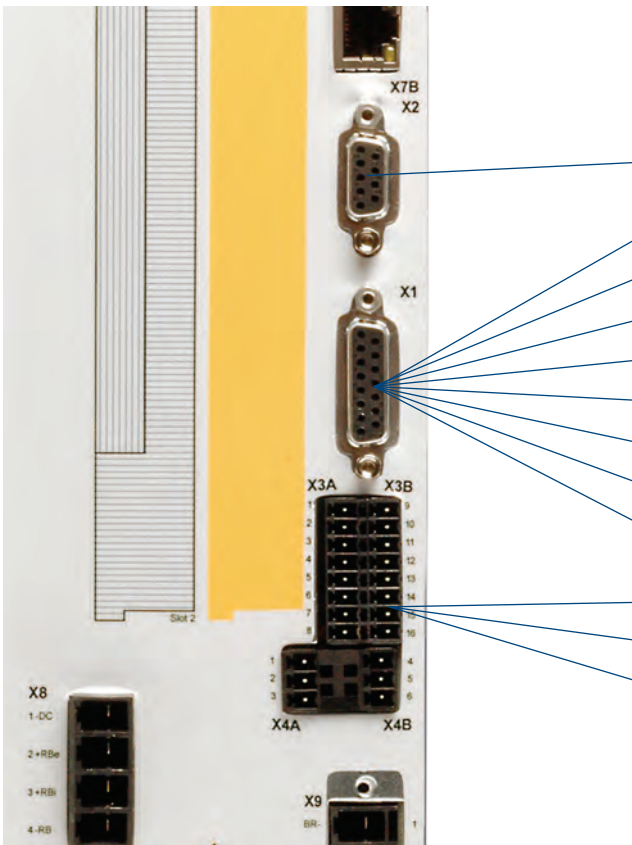

2 to 36-pin resolvers

SinCos encoder with BISS

SinCos encoder with ENDAT 2.1

SinCos encoder with HIPERFACE

SinCos encoder without data track

SinCos encoder + Hall-effect sensor

Hall-effect sensor

Incremental encoder (AquadB) 5 V

Incremental encoder (AquadB) 5 V + Hall-effect sensor

Incremental encoder (AquadB) 24 V

Incremental encoder (AquadB) 24 V + Hall-effect sensor

Pulse/direction 24 V

### Optional

SSI absolute encoder

Pulse/direction 5 V

## DriveGUI setup software

To facilitate initial setup of the S700, we provide graphics-based Windows® software that offers access to all S700 parameters and functions.

All S700 interfaces can be configured, any connected devices (e.g. motor type, feedback system, fieldbus) can be selected and the Autotuning functions can be launched. A four-channel oscilloscope and Bode plot ensure optimum display of the Autotuning results. Specialists are able to address all existing parameters via an integrated terminal window. Thanks to the Bode plot function, resonant frequencies of the machinery can be suppressed. This makes for quieter operation and optimizes the production process.

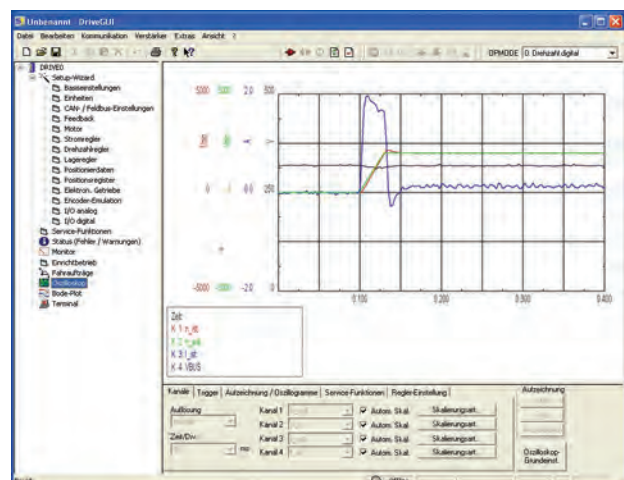

## Safety function

Safe Torque Off (STO) is integrated as standard. The drive for ever-greater productivity means that safe intervention has to be ensured even when the motor remains switched on (in order to hold a load or slow down machinery, for

example). That is why the S700 has been equipped with a slot for a safety expansion card, which supports advanced safety functions, such as Safely Limited Speed and Safe Stop 2.

Safe Torque Off (STO)

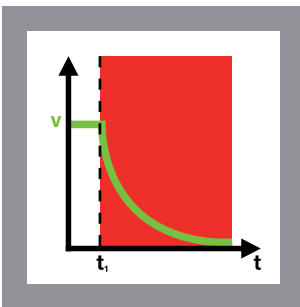

Safe Stop 1 (SS1)

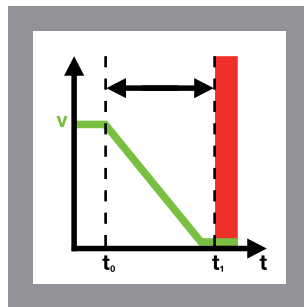

Safe Stop 2 (SS2)

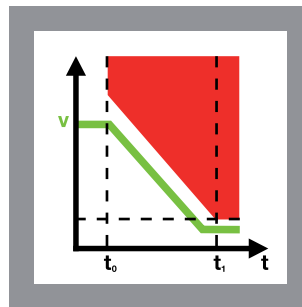

Safe Operating Stop (SOS)

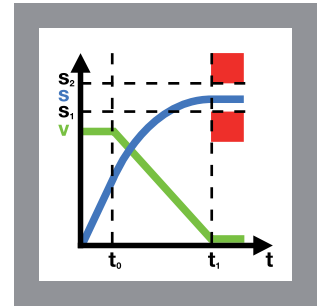

Safe Direction (SDI)

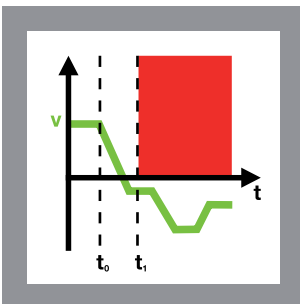

Safe Speed Range 1 (SSR)

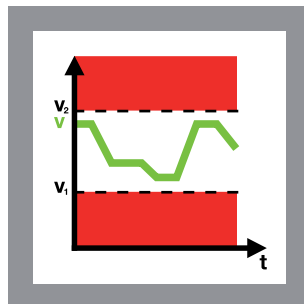

Safely Limited Speed (SLS)

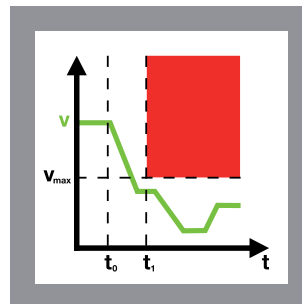

Sources: Pilz, [www.pilz.com](http://www.pilz.com)

## Cogging torque suppression

The servo motors produced by many manufacturers manifest a noticeably high cogging torque as a result of how the permanent magnets are arranged. The S700 offers a function for suppressing cogging torque within defined traverse distances. This function has been specifically

designed for applications with the toughest synchronism requirements. Even linear motors can be operated at extremely low speeds with a high degree of synchronous accuracy.

## Multi-interface

The S700 really stands out on account of the high level of flexibility that it offers when integrated into network environments. Virtually all of the most popular fieldbus connections can be accommodated, thereby enabling the servo amplifier to communicate with any standard controller.

### Standard

#### RS232

- Standard interface that enables connection to a PC for startup and optimization purposes



- CAN standard ISO 11898 (high-speed communication)
- Max. transmission speed of 1 Mbit/s
- Supports CANopen standards DS301, DSP402



- The firmware can be selected to set the EtherCat protocol for the Ethernet interface

### In preparation

#### Ethernet TCP/IP

#### Profinet

#### Sercos III

### Optional



- SERCOS standard to IEC 61491
- Noise-resistant optical fiber
- Choice of baud rate settings: 2, 4, 8 and 16 Mbaud



- PROFIBUS DP to EN 50170
- Baud rates from 187.5 kbaud to 12 Mbaud
- Support for the PROFIDRIVE drive profile



- CAN standard ISO 11898 (high-speed comm.)
- Max. transmission speed of 500 kbit/s

#### I/O expansion card

- In the case of straightforward automation tasks, the I/O expansion card provides an extremely cost-effective way of implementing servo motor positioning control
- 14 additional digital inputs enable selection and launch of the motion tasks stored in the S700's process block memory
- 8 digital outputs communicate the drive status to the higher-level control system

