

Flange Mounted Clutches – Type FL

FL series power-on clutches are used to couple two parallel shafts. The armature hub assembly is mounted to the same shaft as the rotor assembly. The armature hub accommodates a pulley, gear, sprocket, etc., to transmit torque to the second shaft. The field assembly is mounted to a bulkhead that is perpendicular to the input shaft.

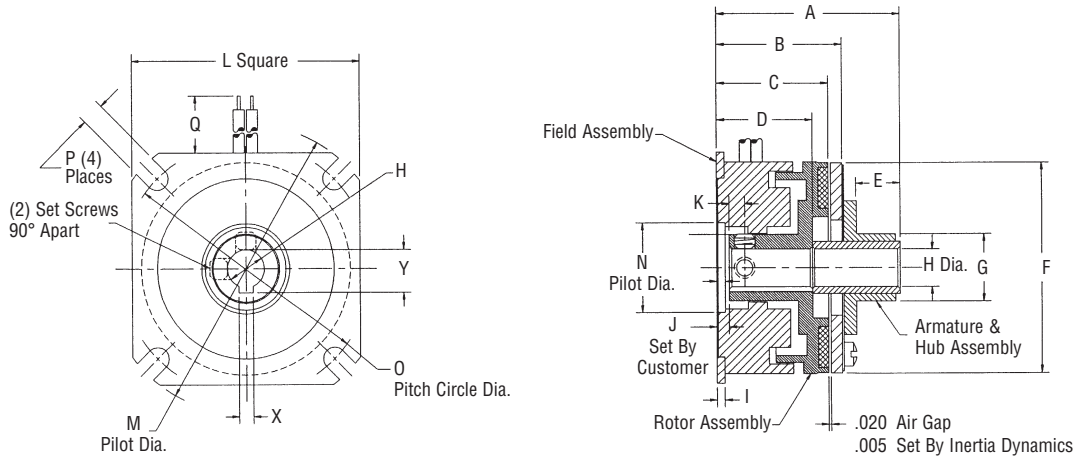

Model FL08 through FL26

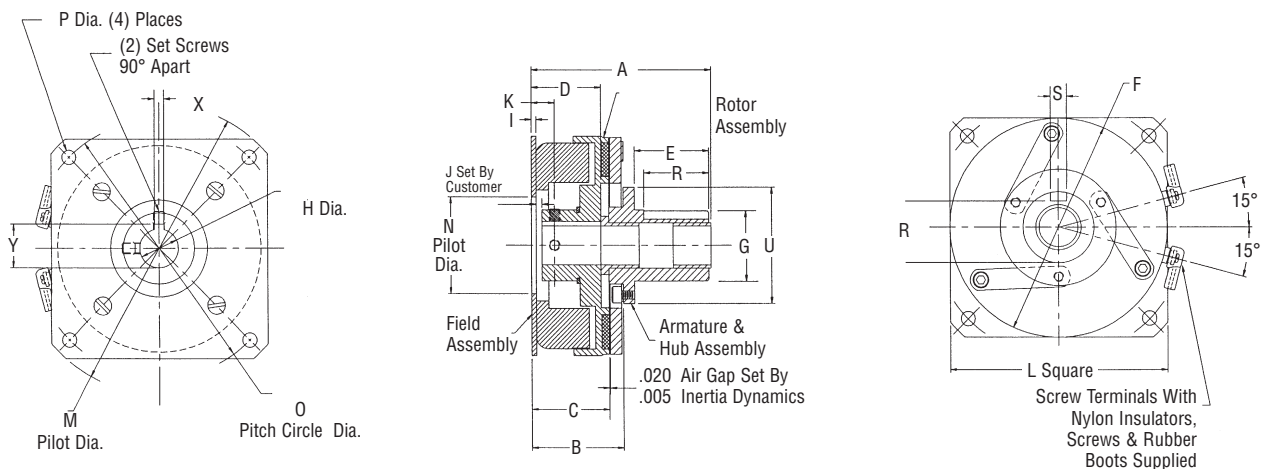

Model FL30 or FL42

Customer Shall Maintain:

the perpendicularity of the mounting surface with respect to the shaft not to exceed .005 inch T.I.R. at a diameter equal to the bolt circle; concentricity between the clutch mounting pilot diameter and the shaft not to exceed .004 inch T.I.R.

Mechanical

MODEL NO.	STATIC TORQUE LB. – IN.	INERTIA LB. – IN. ²		WGT. OZ.
		ROTOR	ARM & HUB	
FL08	2.5	.002	.0015	2.0
FL11	6	.005	.0029	3.2
FL15	10	.0054	.0031	3.8
FL17	15	.059	.036	11
FL19	25	.080	.047	12
FL22	50	.210	.079	20
FL26	80	.451	.292	28
FL30	125	.610	.561	45
FL42	250	2.50	2.30	80

Electrical

MODEL NO.	90 VDC		24 VDC		12 VDC	
	AMPS	OHMS	AMPS	OHMS	AMPS	OHMS
FL08	.046	1977	.117	205	.246	48.8
FL11	.047	1930	.198	121	.447	26.8
FL15	.042	2150	.183	132	.380	31.6
FL17	.066	1369	.289	83	.561	21.4
FL19	.074	1213	.322	74.4	.574	20.9
FL22	.079	1140	.322	74.6	.628	19.1
FL26	.092	980	.374	64.2	.760	15.8
FL30	.091	988	.378	65.3	.729	16.5
FL42	.124	722	.468	51.2	.934	12.84

Lead wire is UL recognized style 1213, 1015 or 1430, 22 gage.
Insulation is .050" O.D. on 08, 11, 15 units; .064" or .095" O.D. on all other units.

Dimensions

MODEL NO.	A MAX.	B NOM.	C NOM.	D NOM.	E MAX.	F MAX.	G ± .002.	H NOM.	I MAX.	J ± .005	K ± .005	L MAX.	M ± .001	N ± .001	O NOM.	P MIN.	Q ± .500	ROTOR KEYWAY						
																		BORE	NOMINAL KEYWAY		R MIN.	S ±.002		
																			X	Y				
FL08	1.203	.715	.641	.582	.410	.905	.507	$\frac{1}{8}$ $\frac{3}{16}$ $\frac{1}{4}$.034	.020	.188	.980	1.1995	N.A.	1.030	.094	12.00	N.A.	ONE ROLL PIN PILOT HOLE		—	—		
FL11	1.253	.774	.691	.616	.396	1.160	.505	$\frac{3}{16}$ $\frac{1}{4}$ $\frac{5}{16}$.048	.020	.188	1.230	1.498	N.A.	1.312	.123	12.00	N.A.	ONE ROLL PIN PILOT HOLE		—	—		
FL15	1.420	.975	.870	.805	.303	1.500	.630	$\frac{1}{4}$ $\frac{3}{16}$ $\frac{3}{8}$.063	.100	.130	1.567	1.999	N.A.	1.750	.156	12.00	N.A.	ONE ROLL PIN PILOT HOLE		—	—		
FL17	1.568	1.053	.925	.800	.382	1.789	.630	$\frac{1}{4}$ $\frac{5}{16}$ $\frac{3}{8}$.064	.100	.130	1.943	2.436	.751	2.125	.186	12.00	$\frac{1}{4}$ $\frac{5}{16}$ $\frac{3}{8}$.0625 – .0655 .0625 – .0655 .094 – .097	.285 – .290 .347 – .352 .417 – .427	—	—		
FL19	1.675	1.050	.910	.790	.470	2.000	.756	$\frac{5}{16}$ $\frac{3}{8}$ $\frac{1}{2}$.062	.100	.130	1.943	2.436	.751	2.125	.186	12.00	$\frac{5}{16}$ $\frac{3}{8}$ $\frac{1}{2}$.0625 – .0655 .094 – .097	.347 – .352 .417 – .427	ROLL PIN HOLE		—	—
FL22	1.928	1.328	1.173	1.023	.432	2.260	.756	$\frac{3}{8}$ $\frac{1}{2}$.096	.100	.188	2.322	2.873	1.001	2.500	.160	18.00	$\frac{3}{8}$ $\frac{1}{2}$.094 – .097 .125 – .128	.417 – .427 .560 – .567	—	—		
FL26	2.173	1.458	1.300	1.150	.472	2.645	.999	$\frac{3}{8}$ $\frac{1}{2}$ $\frac{5}{8}$.064	.375	.172	2.630	3.499	1.062	3.125	.182	18.00	$\frac{3}{8}$ $\frac{1}{2}$ $\frac{5}{8}$.094 – .097 .125 – .128 .1885 – .1905	.417 – .427 .560 – .567 .709 – .716	—	—		
FL30	2.575	1.580	1.310	1.160	.830	3.268	1.374	$\frac{1}{2}$ $\frac{5}{8}$ $\frac{3}{4}$.097	.147	.310	3.200	4.186	1.751	3.750	.182	SCREW TERMINALS	$\frac{1}{2}$ $\frac{5}{8}$ $\frac{3}{4}$.125 – .128 .1885 – .1905 .1885 – .1905	.560 – .567 .709 – .716 .836 – .844	1.198 1.193	.312 .314		
FL42*	3.540	1.760	1.490	1.345	1.550	4.255	1.374	$\frac{1}{2}$ $\frac{5}{8}$ $\frac{3}{4}$ $\frac{7}{8}$ 1	.097	.190	.250	4.255	5.624	1.875	5.000	.276	SCREW TERMINALS	$\frac{1}{2}$ $\frac{5}{8}$ $\frac{3}{4}$ $\frac{7}{8}$ 1*	.125 – .128 .1885 – .1905 .1885 – .1905 .1885 – .1905 .251 – .253	.560 – .567 .709 – .716 .836 – .844 .962 – .970 1.113 – .1.121	1.198 1.193	.312 .314		

* $\frac{7}{8}$ and 1 inch bore in rotor only.

NOTES:

- 08, 11 and 15 units have one roll pin pilot hole in rotor – no set screws.
- 26 units have (3) – #8–32 tapped holes on 1.375 in. B.C. in armature hub face instead of knurl.
- 30 and 42 units have keyway instead of knurl.
- $\frac{7}{8}$ and 1 inch bore in rotor only for 42 unit.

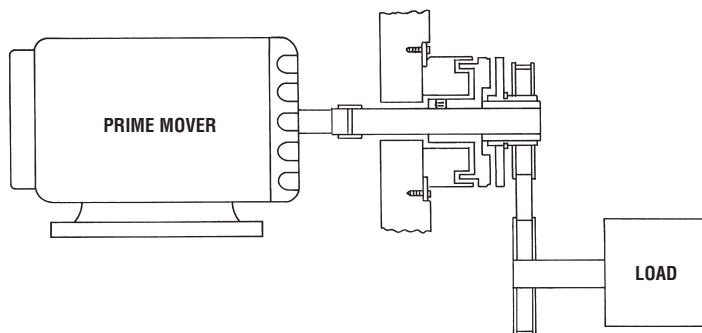

See page 3 for ordering information

PART NUMBERING SYSTEM FOR PRODUCTS ON PAGES 3 TO 35 OF THIS CATALOG

A			A			B		B-C		D		E		F	
DIGIT	DIGIT	MODEL NO.	DIGIT	DIGIT	SIZE	DIGIT	VOLTS	DIGIT	BORE	DIGIT	DRIVE	DIGIT	CONNECTION		
1	7	FSB	0	1	001	1	90 VDC	1	1/8	1	ZERO BACKLASH	1	LEAD WIRES		
1	9	FSBR	0	2	003	2	24 VDC	2	3/16	2	HEX/SQUARE	2	SCREW TERMINALS		
2	1	FSBR (MANUAL RELEASE)	0	3	007	3	12 VDC	3	1/4	3	DYNAMIC (MANUAL RELEASE BRAKE ONLY)	3	SWITCH (MANUAL RELEASE BRAKE ONLY)		
			0	4	015	4	120 VAC	4	5/16	4	STATIC (MANUAL RELEASE BRAKE ONLY)	4	CONDUIT BOX		
			0	5	035			5	3/8	5	SPLINE				
			0	6	050			6	1/2						
			0	7	100			7	5/8						
			0	8	200			8	3/4						
0	1	SL	0	9	08			9	7/8						
0	3	BSL	1	0	11			0	1						
0	5	FL	1	1	15			11	1 1/8						
0	7	SO	1	2	17			12	1 1/4						
0	9	FO	1	3	19			13	1 3/8						
1	1	FB	1	4	22			14	1 1/2						
1	3	SLB	1	5	26										
1	5	SOB	1	6	30										
			1	7	42										
1	8	SAB	1	8	20										
			1	9	90										
			2	1	180										
			2	3	400										
			2	5	1200										

How To Order

- A. Select the model number from the product guide.
- B. Select the size of the clutch or brake.
- C. Select the voltage.
- D. Select the bore diameter.
- E. For all power-on clutches and brakes, select 1. For model FSBR and SAB-20, & 90, select 2. For model FSB spring applied brakes, select 1 or 2. For manual release brakes, select 3 or 4. For SAB-180, 400, & 1200, select 5.
- F. For all clutches and brakes, refer to the product guide and specify 1 or 2. For manual release brakes, if a switch is desired, select 3, otherwise use a 1.

Example

SL11 clutch, 24 volts, 1/4" bore

Part No. 0110-2311

FSB050 brake, 90 volts, 3/8" bore, Hex drive

Part No. 1706-1521