

Harmonic Drive



SHD-2UH-LW Ultra-Flat, Lightweight, Hollow Shaft Gear Unit

Harmonic Drive now offers a lightweight gear unit based upon our SHD Series of Ultra-Flat Hollow Shaft Gears!

Using new lightweight materials and an optimized design Harmonic Drive has developed the SHD-2UH-LW Lightweight Series. These axially compact gear units feature a large hollow input shaft and a robust cross roller bearing so loads can be mounted directly to the unit without the need for additional support bearings.



Sold & Serviced By:



Toll Free Phone (877) SERV098

Toll Free Fax (877) SERV099

www.electromate.com

sales@electromate.com

Ordering Code

SHD - 25 - 100 - 2UH - LW - SP

Model SHD Series	Size 14~40	Gear Ratio 50:1~160:1	Type 2UH (Gearhead)	Lightweight	Special (Custom Specification) leave blank for standard product
----------------------------	----------------------	---------------------------------	-------------------------------	--------------------	--

Rating Table

Table 2-1

Size	Gear Ratio	Rated Torque at 2000 rpm		Limit for Repeated Peak Torque		Limit for Average Torque		Limit for Momentary Torque		Max. Input Speed	Max. Average Input Speed	Moment of Inertia	
		Nm	lb-in	Nm	lb-in	Nm	lb-in	Nm	lb-in	Grease	Grease	I x10 ⁻⁴ kgm ²	J x10 ⁻⁵ kgfms ²
14	50	3.7	33	12	106	4.8	42	23	204	8,500	3,500	0.064	0.065
	100	5.4	48	19	168	7.7	68	35	310				
17	50	11	97	23	204	18	159	48	425	7,300	3,500	0.141	0.144
	100	16	142	37	327	27	239	71	628				
20	50	17	150	39	345	24	212	69	611	6,500	3,500	0.271	0.276
	100	28	248	57	504	34	301	95	841				
	160	28	248	64	566	34	301	95	841				
25	50	27	239	69	611	38	336	127	1,124	5,600	3,500	0.793	0.809
	100	47	416	110	974	75	664	184	1,629				
	160	47	416	123	1,089	75	664	204	1,806				
32	50	53	469	151	1,336	75	664	268	2,372	4,800	3,500	2.900	2.957
	100	96	850	233	2,062	151	1,336	420	3,717				
	160	96	850	261	2,310	151	1,336	445	3,939				
40	50	96	850	281	2,487	137	1,213	480	4,248	4,000	3,000	7.432	7.578
	100	185	1,637	398	3,523	260	2,301	700	6,196				
	160	206	1,823	453	4,009	316	2,797	765	6,771				

1. Moment of Inertia: $I = 1/4GD^2$
2. Please refer to the CSD / SHD Catalog for an explanation of terms and technical information.

Starting Torque

Values shown below vary depending on the operating condition.
 Please use values as a reference.

Table 2-2
 Unit: Ncm

Ratio	Size					
	14	17	20	25	32	40
50	11	39	53	79	114	177
100	8.7	37	49	73	101	157
160	-	-	48	72	97	151

Backdriving Torque

Table 2-3
 Unit: Nm

Ratio	Size					
	14	17	20	25	32	40
50	6.0	21	29	44	63	98
100	9.7	41	54	80	111	173
160	-	-	84	126	171	266

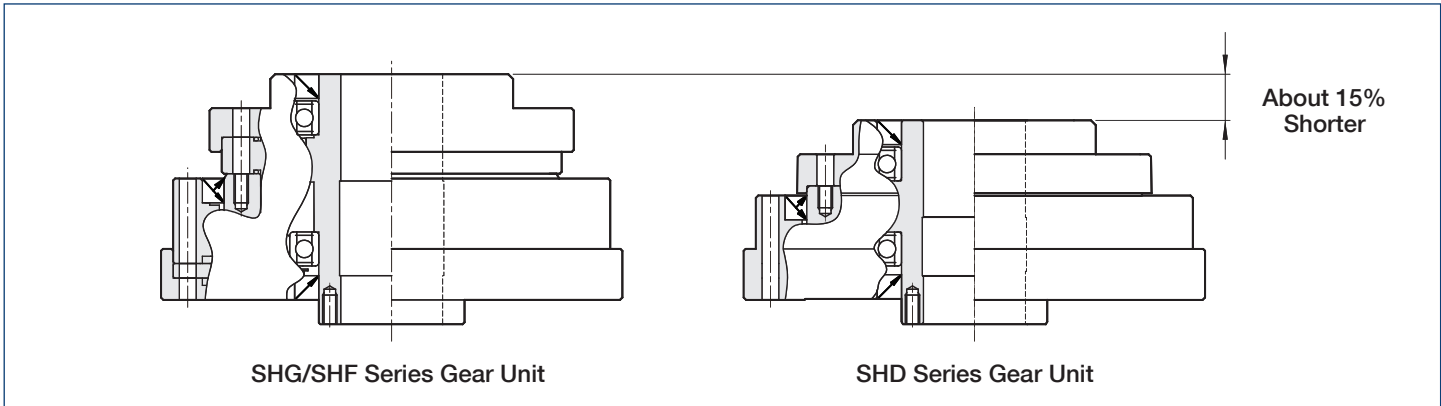
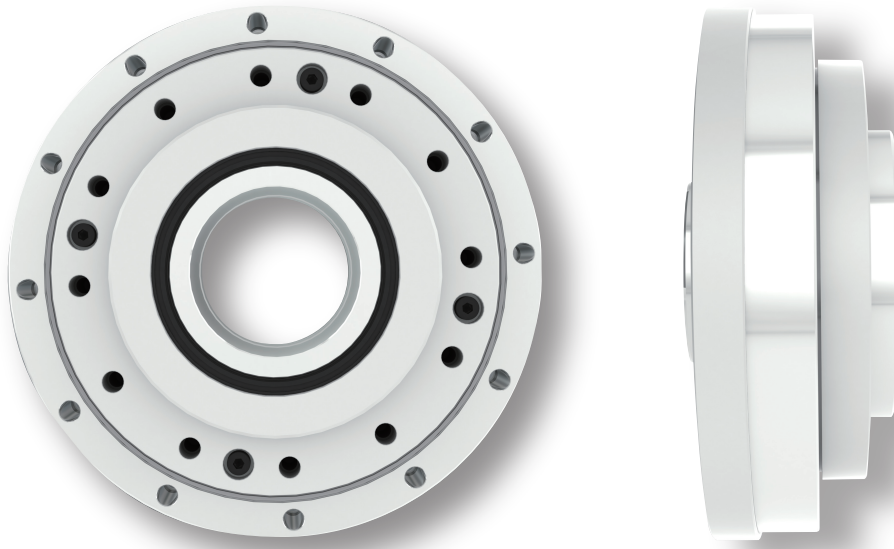

Weight Comparison

Table 3-1
Unit: Kg

Ratio	Size					
	14	17	20	25	32	40
SHG/SHF-2UH Series	0.71	1	1.38	2.1	4.5	7.7
SHD-2UH-LW Lightweight	0.49	0.66	0.84	1.4	2.7	4.6
Weight Ratio	69%	66%	61%	67%	60%	60%

Accuracy

Table 3-2

		Size					
		14	17	20	25	32	40
	x10 ⁻⁴ rad	4.4	4.4	2.9	2.9	2.9	2.9
	arc min	1.5	1.5	1.0	1.0	1.0	1.0

Hysteresis Loss

Table 3-3

Ratio		Size					
		14	17	20	25	32	40
50	x10 ⁻⁴ rad	7.3	5.8	5.8	5.8	5.8	5.8
	arc min	2.5	2.0	2.0	2.0	2.0	2.0
over 100	x10 ⁻⁴ rad	5.8	2.9	2.9	2.9	2.9	2.9
	arc min	2.0	1.0	1.0	1.0	1.0	1.0

No Load Running Torque

No-load running torque is the input torque (high speed shaft) which is required to rotate the Harmonic Drive™ gear with no load applied to the output.

Measurement condition Table 4-1

Ratio: 100			
Lubricant	Grease	Name	Harmonic grease SK-1A
			Harmonic grease SK-2
		Grease quantity	Recommended quantity
Torque value is measured after 2 hour run-in at 2000 rpm input. Please contact HDLLC if you are using oil lubricant.			

Compensation Value for Each Ratio

The no load running torque of Harmonic Drive gears varies with the gear ratio. The graphs below indicate a value for ratio 100. For other gear ratios, add the compensation value from table 4-2.

Table 4-2
Unit: Ncm

Ratio	Size	
	50	160
14	+1.0	—
17	+1.6	—
20	+2.4	-0.7
25	+4.0	-1.2
32	+7.7	-2.4
40	+13	-3.9
50	—	—

No Load Running Torque for Ratio 100

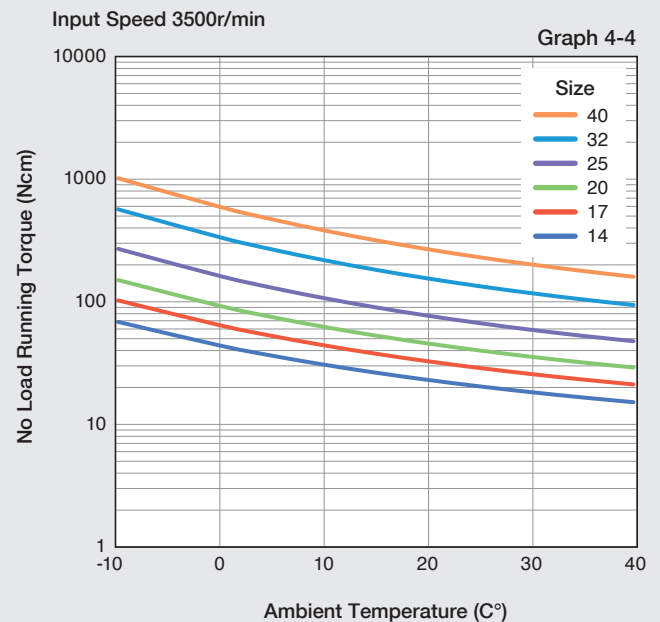
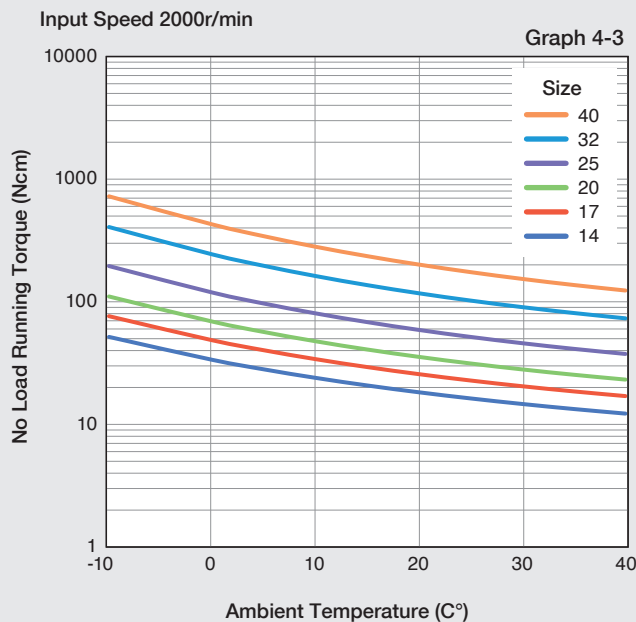
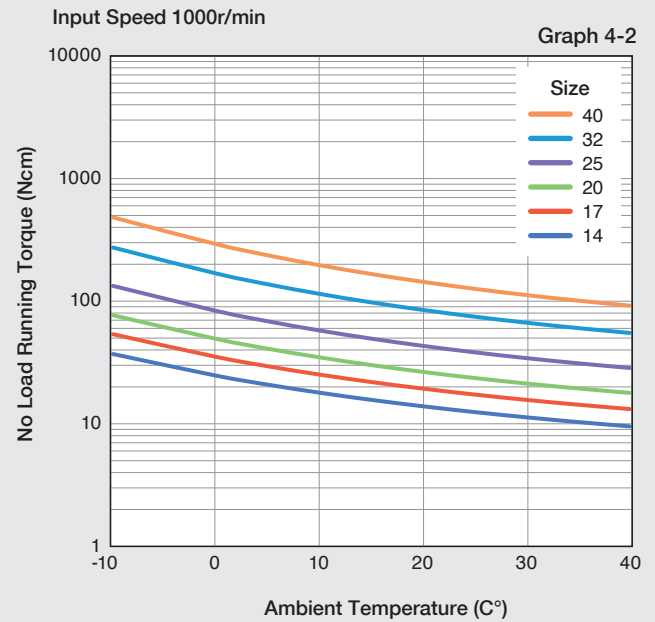
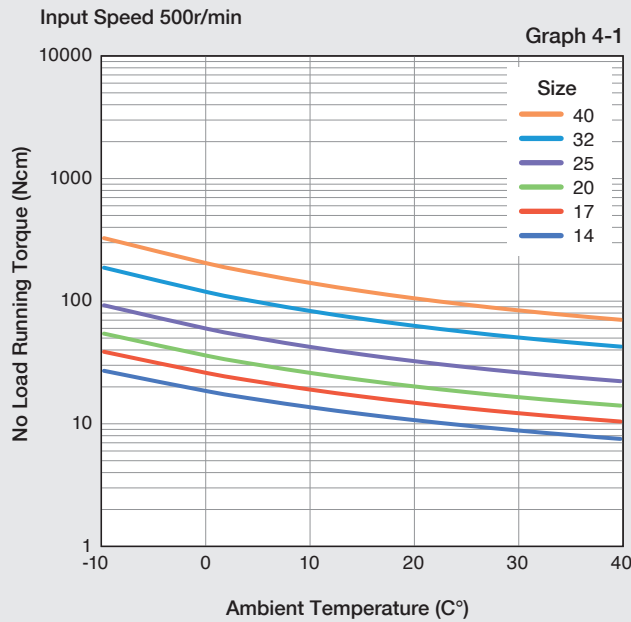

Efficiency

The gear efficiency is affected by many factors. Efficiency depends on the gear ratio, input speed, load torque, temperature, quantity of lubricant and type of lubricant. Efficiency values shown in the tables shown below are for rated torque. If the actual load torque is below rated torque, a compensation factor must be used.

Load Torque \geq Rated Torque : Efficiency = Efficiency from Graph 5-2 thru 5-6.

Load Torque $<$ Rated Torque : Efficiency = Efficiency from Graph 5-2 thru 5-6 x Compensation Coefficient from Graph 5-1.

Graph 5-1

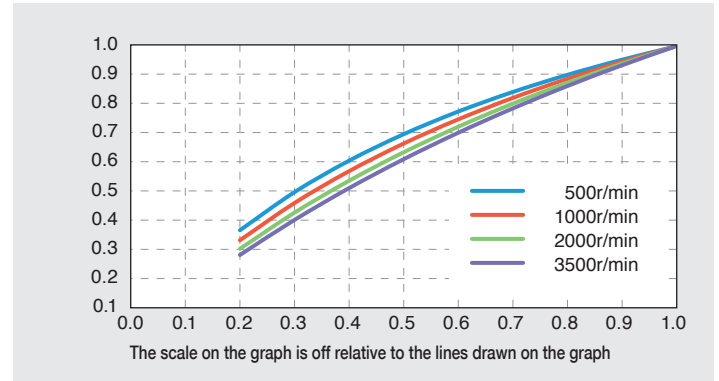

Measurement condition Table 4-1

Based on recommended tolerance			
Rated torque			
Lubricant	Grease	Name	Harmonic grease SK-1A
		Grease quantity	Recommended quantity

Efficiency at Rated Torque (Size 14)

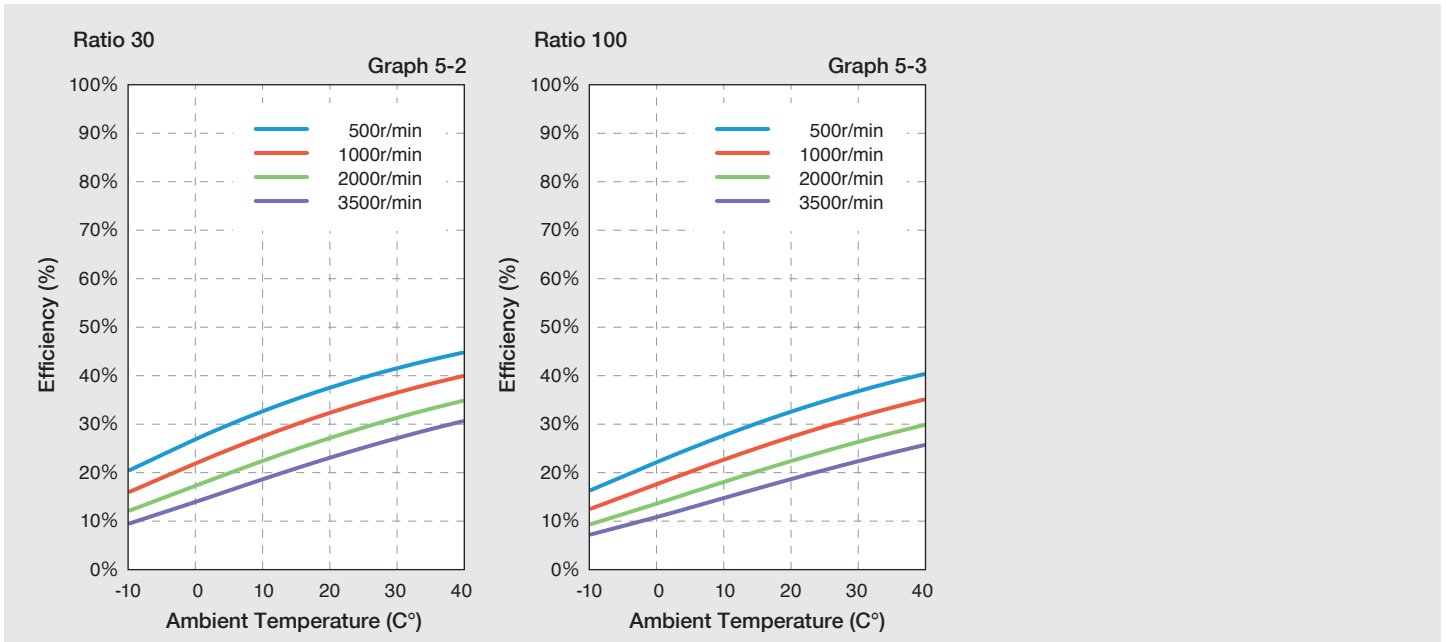

Efficiency at Rated Torque (Sizes 17, 20, 25, 32, 40)

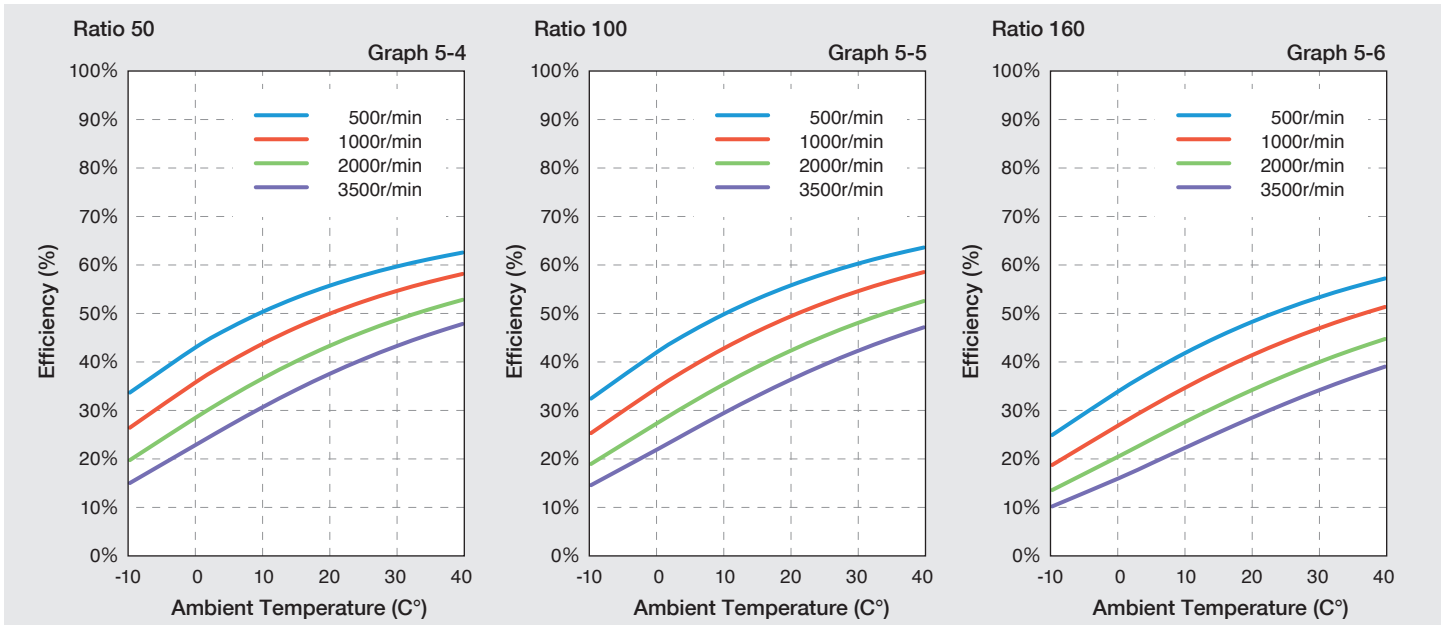

External Dimensions

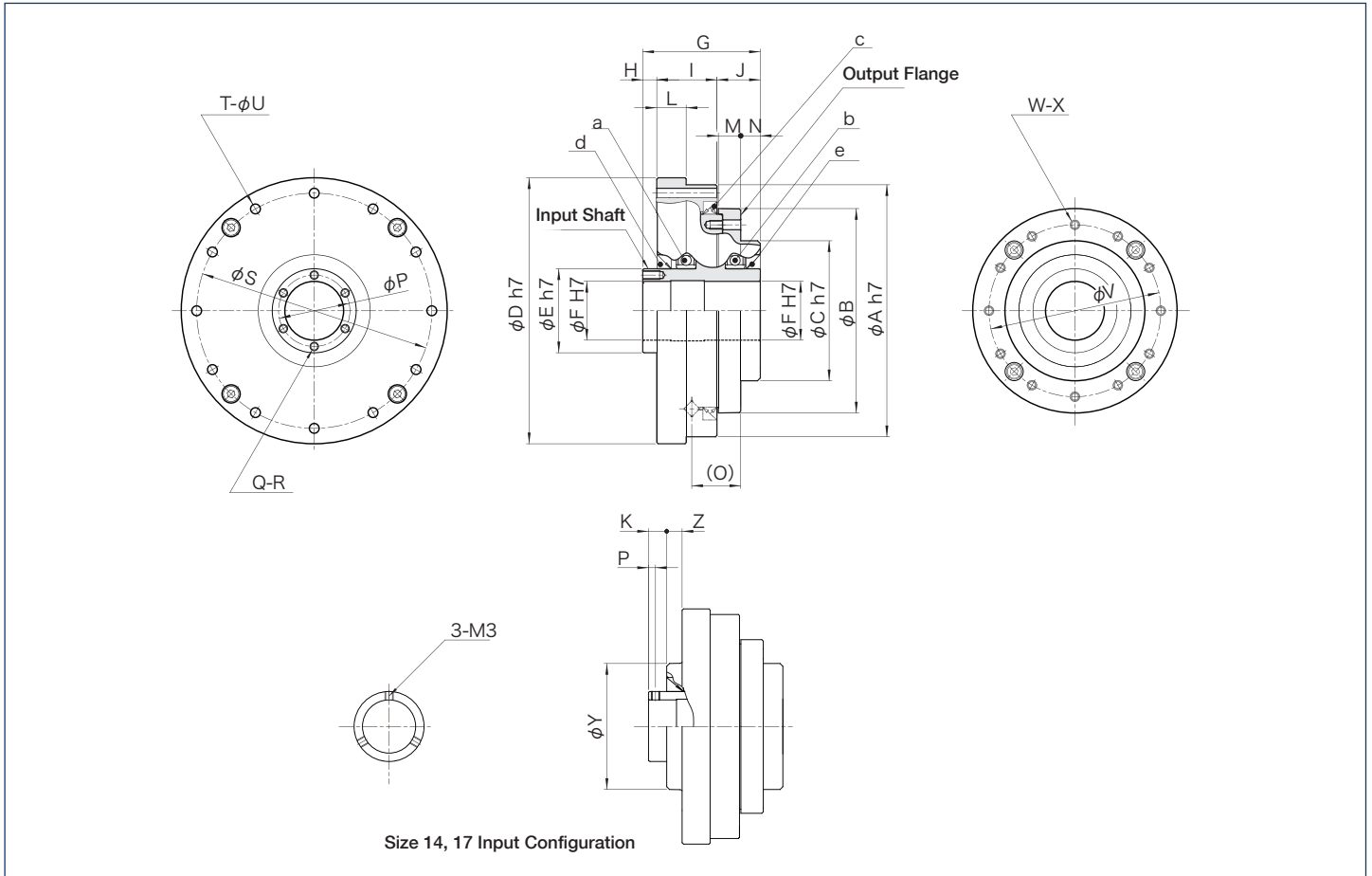

Dimension Table

Table 6-1

Symbol	Size					
	14	17	20	25	32	40
φA h7	70	80	90	110	142	170
φB	52	62	73	87	114	137
φC h7	36	45	50	60	75	100
φD h7	74	84	95	115	147	175
φE h7	20	25	30	38	54	64
φF H7	14	19	21	29	41	51
G	45.5	48	42	46.5	55	65
H	12	12	5	6	7	8
I	19.5	20.5	21.5	24	28.6	33
J	14	15.5	15.5	16.5	19.4	24
K	6.5	6.5	—	—	—	—
L	9	10	10.5	10.5	12	14
M	7	8	8	10	11	14
N	6.5	7	7	6	7.5	9
O	16.6	18	17.5	20.6	24.9	29.5
φP(P)	(2.5)	(2.5)	25.5	33.5	48	57
Q	3	3	6	6	6	6
R	M3	M3	M3×6	M3×6	M3×6	M4×8
φS	64	74	84	102	132	158
T	8	12	12	12	12	12
φU	3.5	3.5	3.5	4.5	5.5	6.6
φV	43	52	61.4	76	99	120
W	8	12	12	12	12	16
X	M3×5	M3×6	M3×6	M4×7	M5×8	M6×10
	φ3.5×5.5	φ3.5×6.5	φ3.5×6.5	φ4.5×8.5	φ5.5×7.6	φ6.6×10
φY	36	45	—	—	—	—
Z	5.5	5.5	—	—	—	—
a	6804ZZ	6805ZZ	6806ZZ	6808ZZ	6811ZZ	6813ZZ
b	6804ZZ	6805ZZ	6806ZZ	6808ZZ	6810ZZ	6813ZZ
c	D49585	D59685	D69785	D84945	D1101226	D1321467
d	S20304.5	S25356	S30405	S38475	S54645	S64745
e	S20304.5	S25356	S30405	S38475	S50605	S64745
Weight (kg)	0.49	0.66	0.84	1.4	2.7	4.6

Specification for Crossroller Bearing

Table 7-1

Size	Pitch Circle	Offset	Basic Dynamic Load Rating		Basic Static Load Rating		Allowable Moment Load		Moment Stiffness	
	dp	R	C		Co		Mc		Km	
	m	m	×10 ² N	lb	×10 ² N	lb	Nm	lb-in	×10 ⁴ Nm/rad	×10 ⁴ lb-in/rad
14	0.0503	0.0111	29	652	43	967	37	327	7.08	63
17	0.061	0.0115	52	1,169	81	1,821	62	549	12.7	112
20	0.070	0.011	73	1,641	110	2,473	93	823	21	186
25	0.086	0.0121	109	2,450	179	4,024	129	1,142	31	274
32	0.112	0.0173	191	4,294	327	7,351	290	2,567	82.1	727
40	0.133	0.0195	216	4,856	408	9,172	424	3,753	145	1,283

* The moment stiffnesses are mean values.

Installation and Transmission Torque

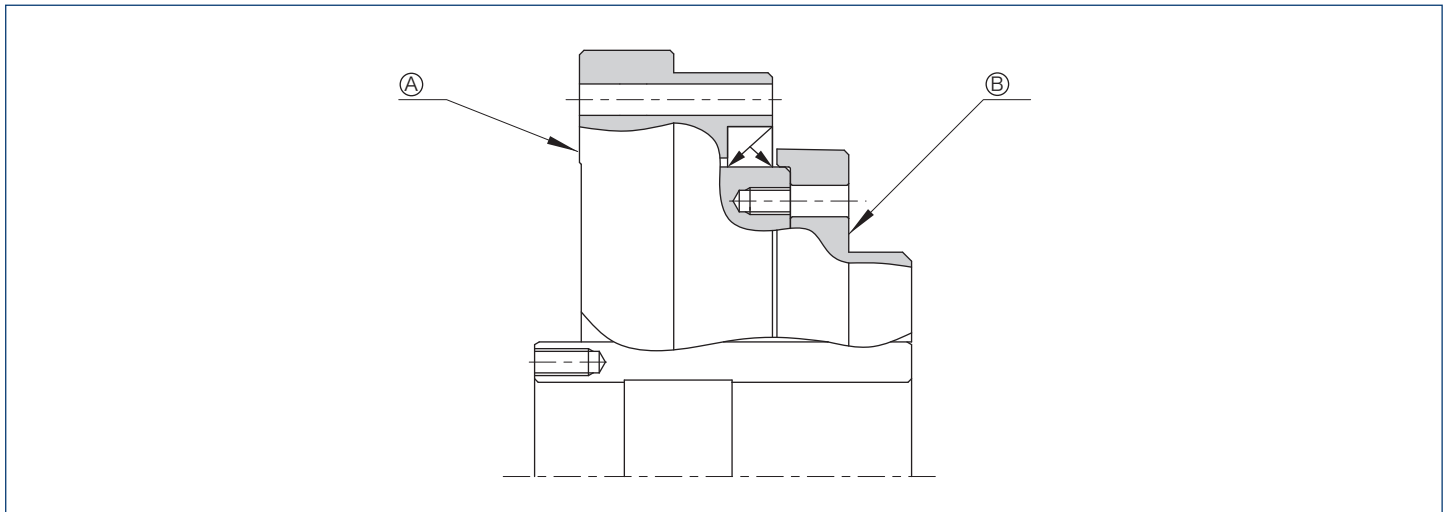

Bolt connection to housing and resulting transmission torque (A)

Table 7-2

	Size					
	14	17	20	25	32	40
Number of screws	8	12	12	12	12	12
Size of screws	M3	M3	M3	M4	M5	M6
Pitch Circle Diameter mm	64	74	84	102	132	158
Screw Tightening Torque	Nm	2.0	2.0	2.0	4.5	9.0
	lb-in	18	18	18	40	80
Torque Transmitting Capacity	Nm	108	186	210	431	892
	lb-in	956	956	1,823	3,815	7,895

Bolt connection to output flange and resulting transmission torque (B)

Table 7-3

	Size					
	14	17	20	25	32	40
Number of screws	8	12	12	12	12	12
Size of screws	M3	M3	M3	M4	M5	M6
Pitch Circle Diameter mm	43	52	61.4	76	99	120
Effective Thread Depth	4.5	4.5	4.5	6	8	9
Screw Tightening Torque	Nm	2.0	2.0	2.0	4.5	9.0
	lb-in	18	18	18	40	80
Torque Transmitting Capacity	Nm	72	130	154	321	668
	lb-in	637	1,151	1,363	2,841	5,912

1. Recommended bolt : JIS B 1176 socket head cap screw strength range : JIS B 1051 over 12.9

2. Torque coefficient : K=0.2

3. Clamp coefficient A=1.4

4. Coefficient of friction: 0.15

5. Strict compliance to the recommended screw tightening torques is especially important for the lightweight aluminum housing flange. Exceeding the recommended values (over tightening) can cause deformation of the housing flange under the bolt heads. This will result in the housing slipping under full torque loads. Flat washers should be used for all screws in direct contact with the aluminum housing. (Please contact a Sales Engineer for more information.)

Input Shaft Load Limits

The Hollow Shaft Unit type is supported by two deep groove single row ball bearings. To achieve peak performance, it is essential to confirm that the actual load applied to input shaft does not exceed the limits specified below.

Figure 8-1 shows the points of application of forces, which determine the Maximum Allowable Radial and Axial Loads as indicated in Graph 8-1. The maximum values, as given Graph 8-1 are valid for an average input speed of 2,000 rpm and a mean bearing life of $L_{10}=7,000h$. Example: If the hollow shaft of a SHD-40-2UH-LW unit is subjected to an axial load of 400 N, the maximum allowable radial force will be 275 N.

Bearing Specification for Input Side

Table 8-1

Size	Bearing A			Bearing B			a Overhung Distance (mm)	b Distance between Bearings (mm)	Max. Radial Load Fr(N)
	Bearing Model	Basic Dynamic Load Rating	Basic Static Load Rating	Bearing Model	Basic Dynamic Load Rating	Basic Static Load Rating			
		Cr(N)	Cor(N)		Cr(N)	Cor(N)			
14	6804ZZ	4,000	2,470	6804ZZ	4,000	2,470	16.5	20.0	179
17	6805ZZ	4,500	3,150	6805ZZ	4,500	3,150	18.0	19.5	191
20	6806ZZ	4,700	3,650	6806ZZ	4,700	3,650	15.5	17.5	199
25	6808ZZ	6,350	5,550	6808ZZ	6,350	5,550	16.5	21.0	290
32	6811ZZ	8,800	8,500	6810ZZ	6,400	6,200	19.5	26.0	410
40	6813ZZ	11,900	12,100	6813ZZ	11,900	12,100	20.5	33.5	602

SHD-2UH-LW Input Shaft Load Limit

Graph 8-1

