

Harmonic Drive™

CSF-LW – Lightweight Gear Unit



Harmonic Drive now offers a NEW lightweight version of our CSF-2UH Gear Units!

30% lighter than our standard CSF-2UH!

Using new lightweight materials and an optimized design, a 30% reduction in weight has been achieved without reducing the torque rating of the gear unit or changing the interface dimensions. This weight savings dramatically increases the “Torque Density” of the gear making it ideally suited for many applications including...

Industrial Robots – allowing operation with higher acceleration rates and payload capacity

Mobile Robots – allowing lower weight designs which improves battery life without sacrificing performance

Application Examples

Robot Wrist

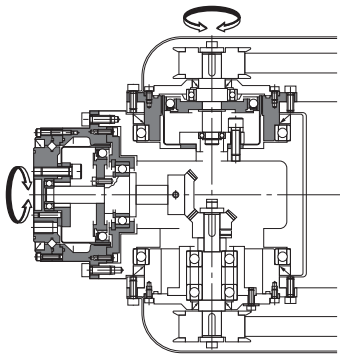

5th and 6th axis drive for the wrist of an Industrial Robot

SCARA Robot Arm

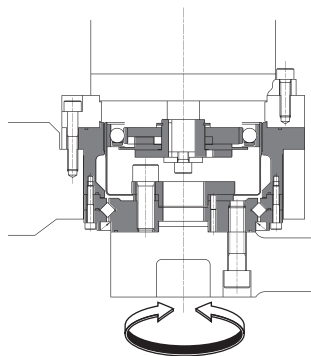

Drive for SCARA Robot

Direct Connection to a Servo Motor

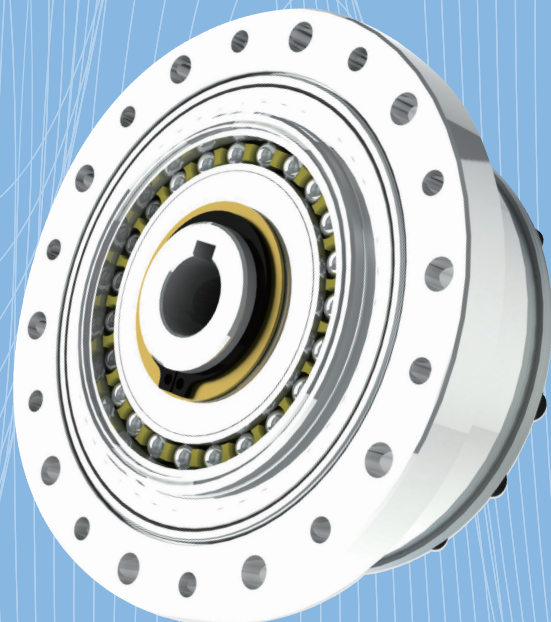
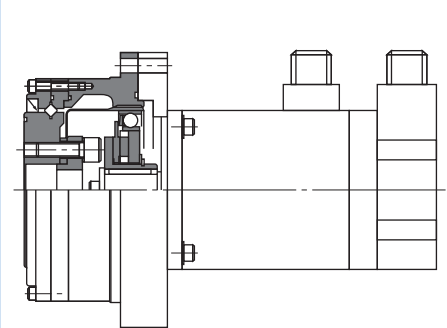

Sold & Serviced By:

 **ELECTROMATE**

Toll Free Phone (877) SERV098

Toll Free Fax (877) SERV099

www.electromate.com

sales@electromate.com

Ordering Code

CSF - 25 - 100 - 2UH - LW - SP

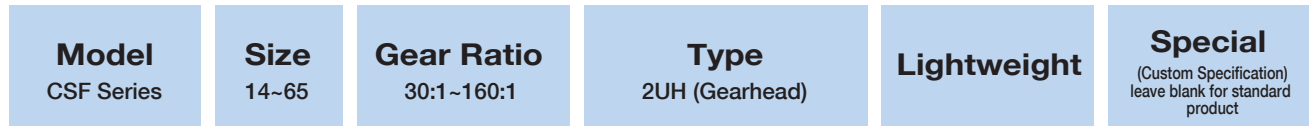

Rating Table

Table 2-1

Size	Ratio	Rated Torque at 2000rpm		Limit for Repeated Peak Torque		Limit for Average Torque		Limit for Momentary Peak Torque		Maximum Input Speed		Limit for Average Input Speed		Moment of Inertia	
		Nm	lb-in	Nm	lb-in	Nm	lb-in	Nm	lb-in	Oil	Grease	Oil	Grease	^I x10 ⁻⁴ kgm ²	^J x10 ⁻⁵ kgfms ²
14	30	4.0	35	9.0	80	6.8	60	17	150	14,000	8,500	6,500	3,500	0.033	0.034
	50	5.4	48	18	159	6.9	61	35	310						
	80	7.8	69	23	204	11	97	47	416						
	100	7.8	69	28	248	11	97	54	478						
17	30	8.8	78	16	142	12	106	30	266	10,000	7,300	6,500	3,500	0.079	0.081
	50	16	142	34	301	26	230	70	620						
	80	22	195	43	381	27	239	87	770						
	100	24	212	54	478	39	345	108	956						
	120	24	212	54	478	39	345	86	761						
20	30	15	133	27	239	20	177	50	443	10,000	6,500	6,500	3,500	0.193	0.197
	50	25	221	56	496	34	301	98	867						
	80	34	301	74	655	47	411	127	1,124						
	100	40	354	82	726	49	434	147	1,301						
	120	40	354	87	770	49	434	147	1,301						
25	30	27	239	50	443	38	336	95	841	7,500	5,600	5,600	3,500	0.413	0.421
	50	39	345	98	867	55	487	186	1,646						
	80	63	558	137	1,213	87	770	255	2,257						
	100	67	593	157	1,390	108	956	284	2,514						
	120	67	593	167	1,478	108	956	304	2,691						
32	30	54	478	100	885	75	664	200	1,770	7,000	4,800	4,600	3,500	1.69	1.72
	50	76	673	216	1,912	108	956	382	3,381						
	80	118	1,044	304	2,691	167	1,478	568	5,027						
	100	137	1,212	333	2,947	216	1,912	647	5,726						
	120	137	1,212	353	3,124	216	1,912	686	6,072						
40	50	137	1,212	402	3,558	196	1,735	686	6,072	5,600	4,000	3,600	3,000	4.50	4.59
	80	206	1,823	519	4,594	284	2,514	980	8,674						
	100	265	2,345	568	5,027	372	3,292	1,080	9,559						
	120	294	2,602	617	5,461	451	3,992	1,180	10,444						
	160	294	2,602	647	5,726	451	3,992	1,180	10,444						
45	50	176	1,558	500	4,425	265	2,345	950	8,408	5,000	3,800	3,300	3,000	8.68	8.86
	80	313	2,770	706	6,249	390	3,452	1,270	11,240						
	100	353	3,124	755	6,682	500	4,425	1,570	13,896						
	120	402	3,558	823	7,284	620	5,487	1,760	15,577						
	160	402	3,558	882	7,806	630	5,576	1,910	16,905						
50	50	245	2,168	715	6,328	350	3,098	1,430	12,657	4,500	3,500	3,000	2,500	12.5	12.8
	80	372	3,292	941	8,329	519	4,594	1,860	16,462						
	100	470	4,160	980	8,674	666	5,895	2,060	18,233						
	120	529	4,682	1,080	9,559	813	7,196	2,060	18,233						
	160	529	4,682	1,180	10,444	843	7,461	2450	21,684						
58	50*	353	3,124	1,020	9,028	520	4,602	1,960	17,347	4,000	3,000	2,700	2,200	27.3	27.9
	80	549	4,859	1,480	13,099	770	6,815	2,450	21,684						
	100	696	6,160	1,590	14,073	1,060	9,382	3,180	28,145						
	120	745	6,594	1,720	15,223	1,190	10,532	3,330	29,473						
	160	745	6,594	1,840	16,285	1,210	10,709	3,430	30,358						
65	50*	490	4,337	1,420	12,568	720	6,373	2,830	25,048	3,500	2,800	2,400	1,900	46.8	47.8
	80	745	6,594	2,110	18,675	1,040	9,205	3,720	32,925						
	100	951	8,417	2,300	20,357	1,520	13,453	4,750	42,041						
	120	951	8,417	2,510	22,215	1,570	13,896	4,750	42,041						
	160	951	8,417	2,630	23,277	1,570	13,896	4,750	42,041						

1. Moment of Inertia: I=1/4GD². 2. Please refer to the CSF/CSG Series catalog for an explanation of terms and technical information not included in this brochure. 3. *Gear units size 50 and over with a gear ratio of 50:1 must use oil lubrication. If it is necessary to use grease, the rated torque is reduced by 50%.

No Load Running Torque

No-load running torque is the input torque (high speed shaft) which is required to rotate the Harmonic Drive™ gear with no load applied to the output.

Measurement condition Table 3-1

Ratio: 100			
Lubricant	Grease	Name	Harmonic grease SK-1A
			Harmonic grease SK-2
		Grease quantity	Recommended quantity
Torque value is measured after 2 hour run-in at 2000 rpm input. Please contact HDLLC if you are using oil lubricant.			

Compensation Value for Each Ratio

The no load running torque of Harmonic Drive gears varies with the gear ratio. The graphs indicate a value for ratio 100. For other gear ratios, add the compensation value from table 3-2.

Table 3-2
Unit: Ncm

Size \ Ratio	30	50	80	120	160
14	2.5	1.1	0.2	—	—
17	3.8	1.6	0.3	-0.2	—
20	5.4	2.3	0.5	-0.3	-0.8
25	8.8	3.8	0.7	-0.5	-1.2
32	16	7.1	1.3	-0.9	-2.2
40	—	12	2.1	-1.5	-3.5
45	—	16	2.9	-2.1	-4.9
50	—	21	3.7	-2.6	-6.2
58	—	30	5.3	-3.8	-8.9
65	—	41	7.2	-5.1	-12

No Load Running Torque for Ratio 100

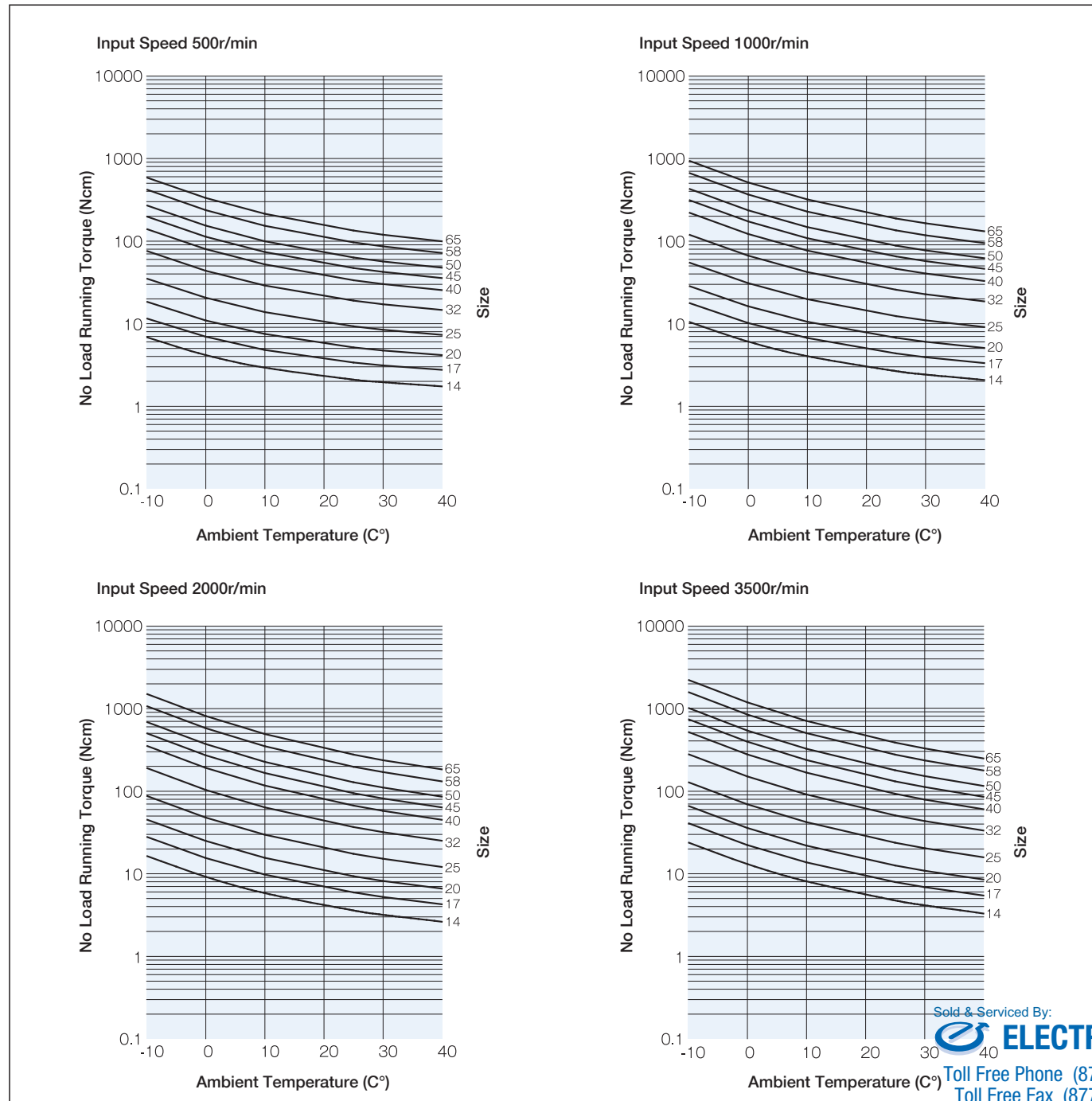

Efficiency

The gear efficiency is affected by many factors. Efficiency depends on the gear ratio, input speed, load torque, temperature, quantity of lubricant and type of lubricant. Efficiency values shown in the tables shown below are for rated torque. If the actual load torque is below rated torque, a compensation factor must be used.

Load Torque ≥ Rated Torque : Efficiency = Efficiency from Graph
 Load Torque < Rated Torque : Efficiency = Efficiency from Graph x Compensation Coefficient from Graph 4-1.

Measurement condition

Table 4-1

Installation	Based on recommended tolerance		
Load torque	Rated torque		
Lubricant	Grease	Name	Harmonic grease SK-1A
		Grease quantity	Recommended quantity

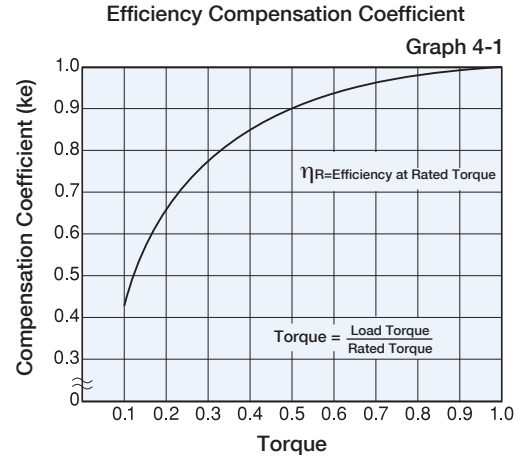

Efficiency at Rated Torque (Size 14)

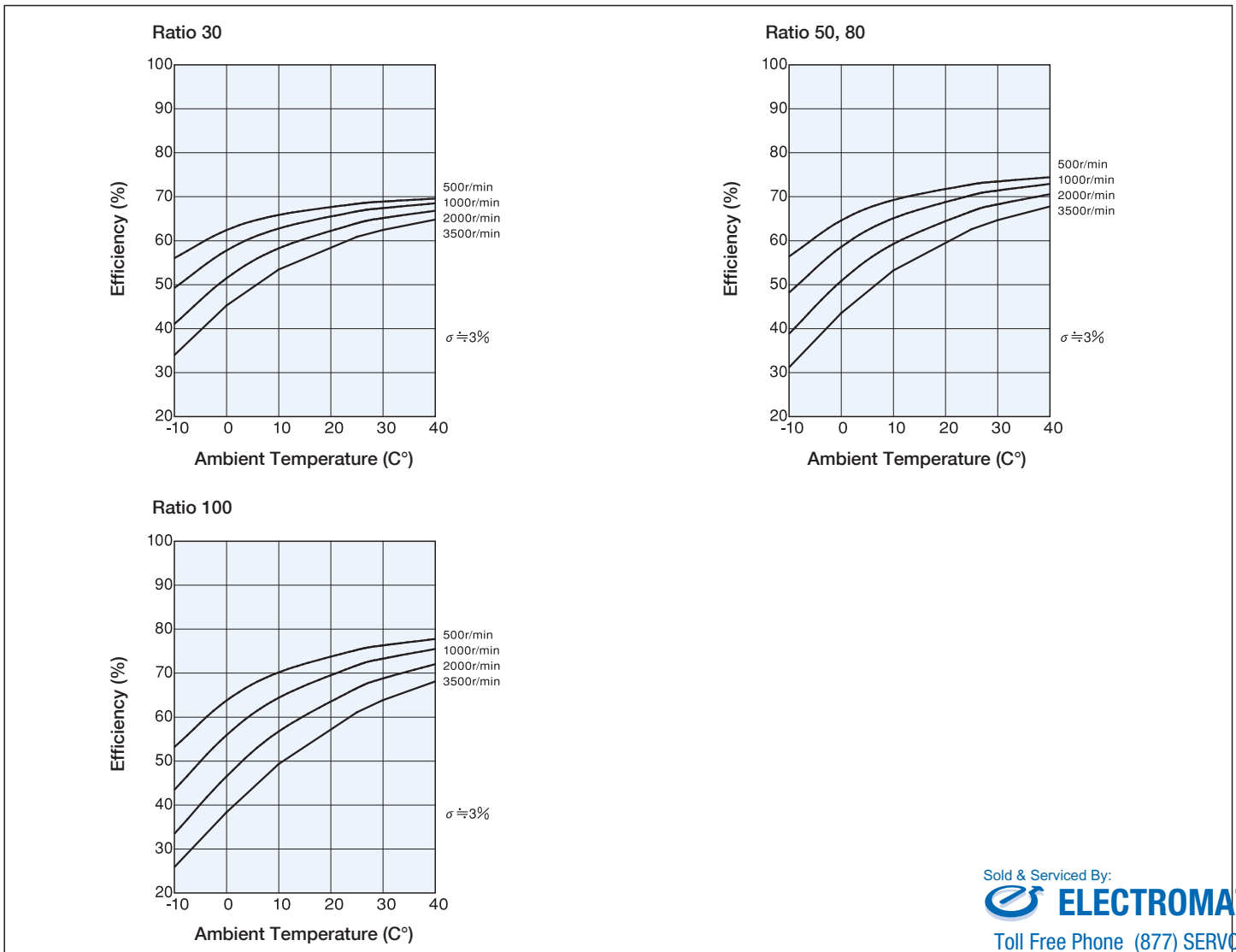

Sold & Serviced By:

 Toll Free Phone (877) SERV098
 Toll Free Fax (877) SERV099
www.electromate.com
sales@electromate.com

Efficiency

Efficiency at Rated Torque (Sizes 17-65)

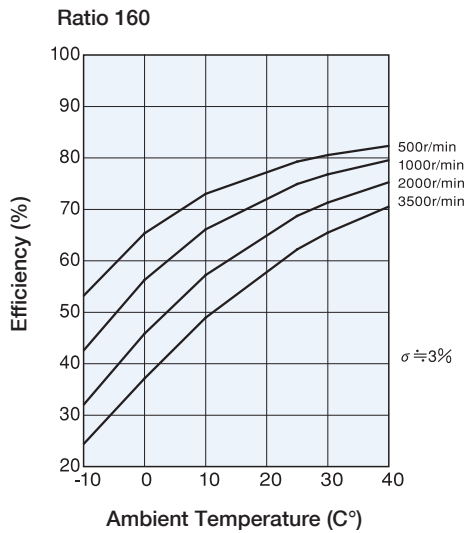
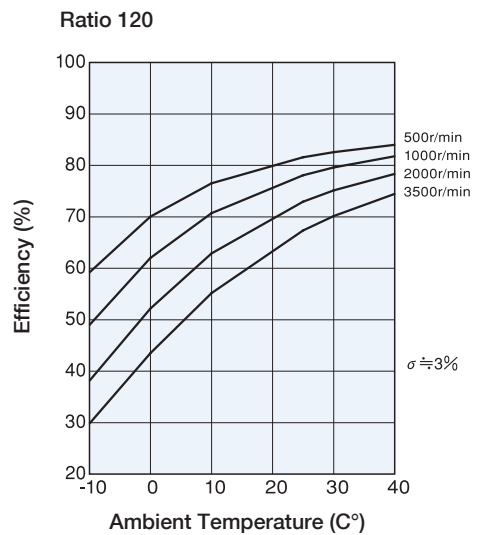
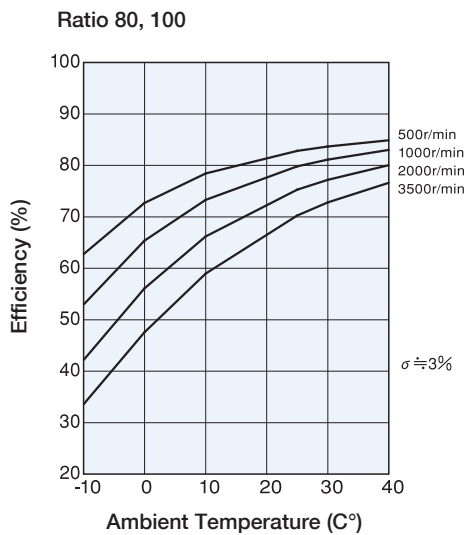
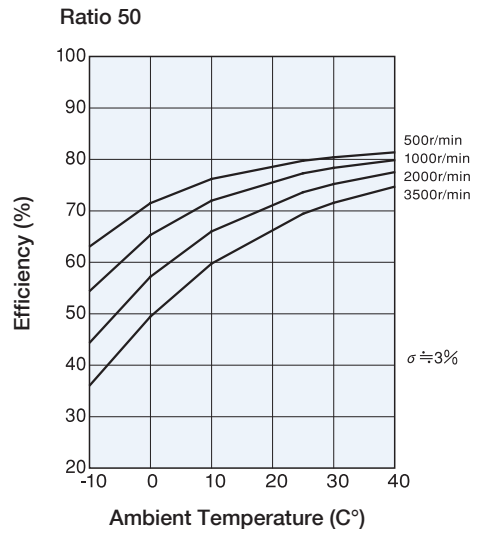
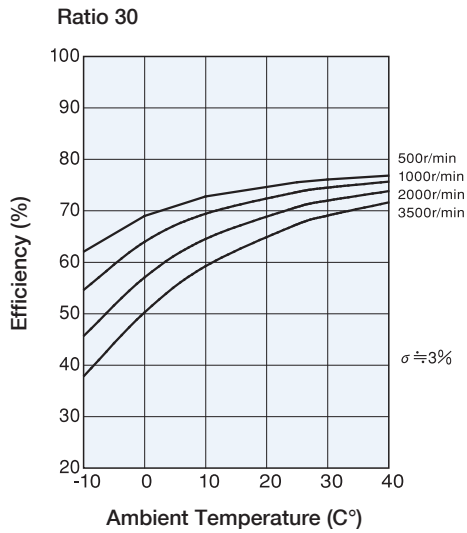

External Dimensions

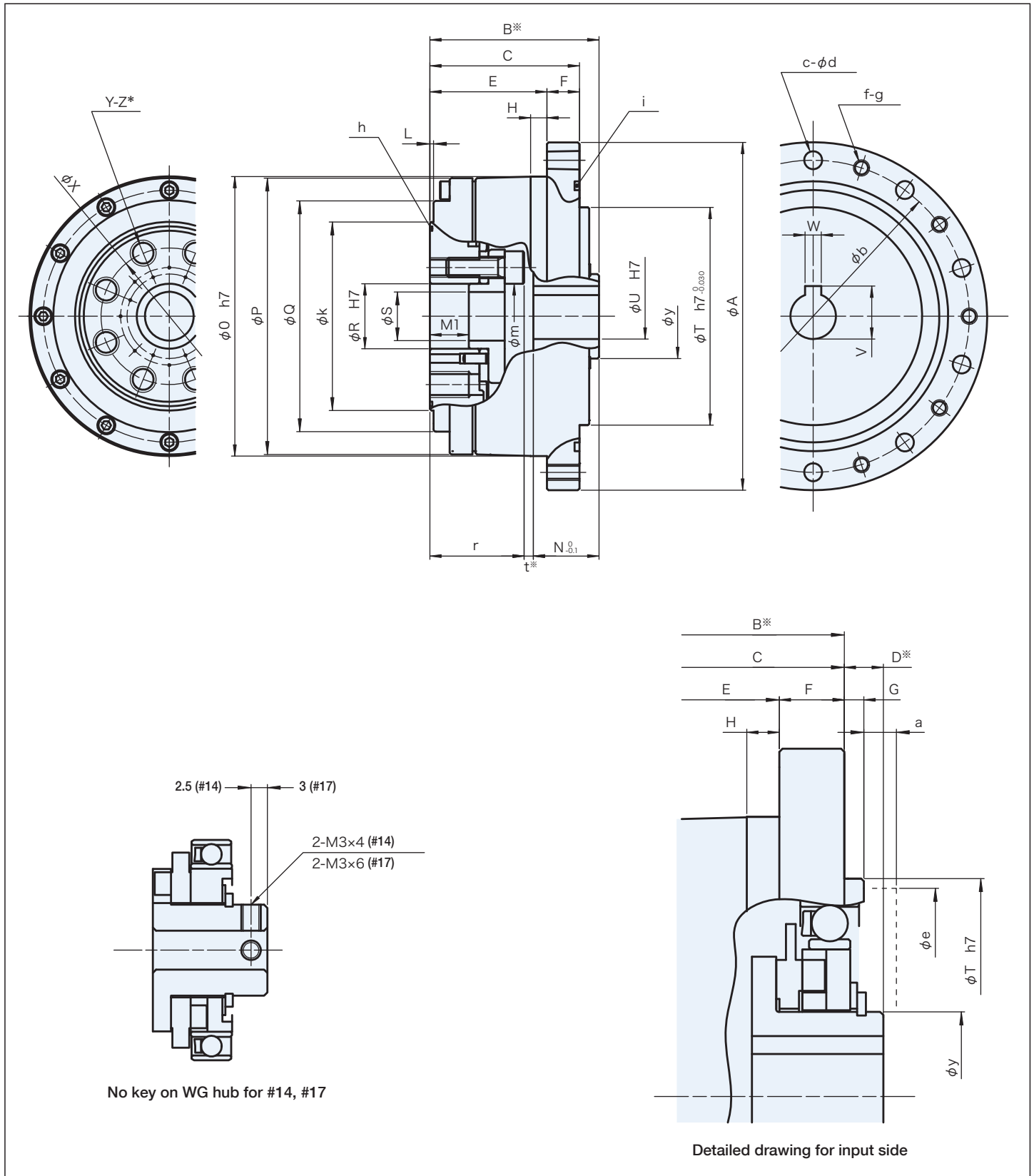

Please contact Harmonic Drive LLC for installation drawings.

* Please Note: The bolts must not extend beyond the length of the threaded hole. If the length of thread engagement exceeds dimension 'Z', damage to the flexspine may occur. Please refer to installation drawing.

Sold & Serviced By:

ELECTROMATE

Toll Free Phone (877) SERV098

Toll Free Fax (877) SERV099

www.electromate.com

sales@electromate.com

Dimension Table

Table 7-1
Unit: mm

Symbol \ Size	14	17	20	25	32	40	45	50	58	65
ϕA	73	79	93	107	138	160	180	190	226	260
B*	41 ⁰ _{-0.9}	45 ⁰ _{-0.9}	45.5 ⁰ _{-1.0}	52 ⁰ _{-1.0}	62 ⁰ _{-1.1}	72.5 ⁰ _{-1.1}	79.5 ⁰ _{-1.2}	90 ⁰ _{-1.3}	104.5 ⁰ _{-1.3}	115 ⁰ _{-1.3}
C	34	37	38	46	57	66.5	74	85	97	108.5
D*	7 ⁰ _{-0.8}	8 ⁰ _{-0.9}	7.5 ⁰ _{-1.0}	6 ⁰ _{-1.0}	5 ⁰ _{-1.1}	6 ⁰ _{-1.1}	5.5 ⁰ _{-1.2}	5 ⁰ _{-1.3}	7.5 ⁰ _{-1.3}	6.5 ⁰ _{-1.3}
E	27	29	28	36	45	50.5	58	69	77	84.5
F	7	8	10	10	12	16	16	16	20	24
G	2	2	3	3	3	4	4	4	5	5
H	4	4	5	5	4.5	4.5	6	6	6	6
L	1.1	1.1	1.1	1.1	1.2	1.6	1.6	1	1.5	1.5
M1	9.4	9.5	9	12	15	5	6	8	10	10
M2	-	-	-	-	-	-	-	-	-	4
N ⁰ _{-0.1}	17.6	19.5	20.1	20.2	22	27.5	27.9	32	34.9	40.9
ϕO h7	56	63	72	86	113	127	148	158	186	212
ϕP	54.6	59.5	70	84.6	110	124.5	143	155	183	208
ϕQ	40.5	47.5	55.5	71	91.1	103	123	130	155	180
$\phi R1$ H7	11	10	14	20	26	32	32	40	46	52
$\phi R2$ H7	-	-	-	-	-	-	-	-	-	142
ϕS	8	7	10	15	20	24	25	32	38	44
ϕT h7	38	48	56	67(68)	90	110	124	135	156	177
ϕU H7	6	8	12	14	14	14	19	19	22	24
V	-	-	13.8 ^{+0.1}	16.3 ^{+0.1}	16.3 ^{+0.1}	16.3 ^{+0.1}	21.8 ^{+0.1}	21.8 ^{+0.1}	24.8 ^{+0.1}	27.3 ^{+0.2}
W Js9	-	-	4	5	5	5	6	6	6	8
ϕX	23	27	32	42	55	68	82	84	100	110
Y	6	6	8	8	8	8	8	8	8	8
Z	M4x8	M5x10	M6x9	M8x12	M10x15	M10x15	M12x18	M14x21	M16x24	M16x24
a	1	1	1.5	1.5	1.5	2	2	2	2.5	2.5
ϕb	65	71	82	96	125	144	164	174	206	236
c	6	8	8	10	14	10	16	18	16	12
ϕd	4.5	4.5	5.5	5.5	6.6	9	9	9	11	14
ϕe	38	45	53	66	86	106	119	133	154	172
f	6	8	8	10	14	10	16	18	16	12
g	M4	M4	M5	M5	M6	M8	M8	M8	M10	M12
h	29.0x0.50	34.5x0.80	40.64x1.14	53.28x0.99	S71	AS568-042	S100	S105	S125	S135
i	S50	S56	S67	S80	S105	S125	S145	S155	S180	S205
ϕk	31	38	45	58	78	90	107	112	135	155
ϕm	10	10.5	15.5	20	27	34	36	39	46	56
r	21.4	23.5	23	29	37	39.5	45.5	53	62.8	66.5
t*	2	2	2.4	2.8	3	5.5	6.1	5	6.8	7.6
u*	6	7	7.4	8.8	11	15.5	18.1	19	22.8	23.6
ϕy	14	18	21	26	26	32	32	32	40	48
Weight (kg)	0.32	0.46	0.64	1.1	2.2	3.5	5.1	7.0	11.3	16.2

Note 1: Dimensions in parentheses indicates values for 30:1 gear ratio.

Note 2: *Dimensions B, D, t and u indicate the location and tolerance of the wave generator flexspline and circular spline. Please strictly comply with these dimensions since it influences performance and strength of the gear.

Weight Comparison

Unit: kg

Size	14	17	20	25	32	40	45	50	58	65
CSF Series standard unit type	0.52	0.68	0.98	1.5	3.2	5.0	7.0	8.9	14.6	20.9
CSF Series LW unit type	0.32	0.46	0.64	1.1	2.2	3.5	5.1	7.0	11.3	16.2
Weight ratio	62%	68%	65%	73%	69%	70%	73%	79%	77%	78%

Sold & Serviced By:



Toll Free Phone (877) SERV098

Toll Free Fax (877) SERV099

www.electromate.com

sales@electromate.com

Specification for Crossroller Bearing

Size	Pitch Circle dp	Offset R	Basic Dynamic Rated Load C		Basic Static Rated Load Co		Allowable Moment Load Mc		Moment Stiffness Km	
	m	m	x10 ² N	lb	x10 ² N	lb	Nm	lb-in	x10 ⁴ Nm/rad	x10 ⁴ lb-in/rad
14	0.035	0.0093	47.0	1,057	60.7	1,365	33.6	297	3.6	32
17	0.0425	0.0091	52.9	1,189	75.5	1,697	52.5	465	6.4	57
20	0.05	0.0098	57.8	1,299	90.0	2,023	74.6	660	10.5	93
25	0.064	0.0118	96.0	2,158	151	3,395	128	1,133	19.8	175
32	0.083	0.0133	150	3,372	250	5,620	257	2,275	44.2	391
40	0.096	0.0148	213	4,788	365	8,206	369	3,266	74.6	660
45	0.111	0.0158	230	5,171	426	9,577	563	4,983	116	1,027
50	0.119	0.0180	348	7,823	602	13,534	622	5,505	140	1,239
58	0.141	0.0205	518	11,645	904	20,323	838	7,417	201	1,779
65	0.16	0.0185	556	12,499	1,030	23,155	1,525	13,497	331	2,930

Installation and Transmission Torque

Bolt connection to output flange and resulting transmission torque

Size		14	17	20	25	32	40	45	50	58	65
Number of screws		6	6	8	8	8	8	8	8	8	8
Size of screws		M4	M5	M6	M8	M10	M10	M12	M14	M16	M16
Pitch circle diameter	mm	23	27	32	42	55	68	82	84	100	110
Screw Tightening Torque	Nm	4.5	9.0	15.3	37	74	74	128	205	319	319
	lb-in	40	80	135	327	655	655	1133	1,814	2,823	2,823
Torque transmitting capacity	Nm	49	91	204	486	1,019	1,258	2,200	3,070	4,980	5,480
	lb-in	434	805	1,806	4,301	9,019	11,134	19,472	27,172	44,077	48,502

Bolt connection to housing and resulting transmission torque

Size		14	17	20	25	32	40	45	50	58	65
Number of screws		6	8	8	10	12	10	16	18	16	12
Size of screws		M4	M4	M5	M5	M6	M8	M8	M8	M10	M12
Pitch circle diameter	mm	65	71	82	96	125	144	164	174	206	236
Screw Tightening Torque ⁵	Nm	3.2	3.2	6.4	6.4	10.8	26.5	26.5	26.5	51.9	90
	lb-in	28	28	57	57	96	235	235	235	459	797
Torque transmitting capacity	Nm	98	143	261	382	842	1,488	2,712	3,237	5,350	6,649
	lb-in	867	1,266	2,310	3,381	7,452	13,170	24,003	28,650	47,351	58,849

1. Recommended bolt : JIS B 1176 socket head cap screw strength range : JIS B 1051 over 12.9

2. Torque coefficient : K=0.2

3. Clamp coefficient A=1.4

4. Coefficient of friction: 0.15

5. Strict compliance to the recommended screw tightening torques is especially important for the lightweight aluminum housing flange. Exceeding the recommended values (over tightening) can cause deformation of the housing flange under the bolt heads. This will result in the housing slipping under full torque loads. (Please contact a Sales Engineer for more information.)