

Miniature Gearheads

Sold & Serviced By:



Toll Free Phone: (877) SERV098
Toll Free Fax: (877) SERV099
www.electromate.com
sales@electromate.com

Harmonic Drive Gearheads
CSF Mini Series
CSF-2XH-F
CSF-2XH-J
CSF-1U

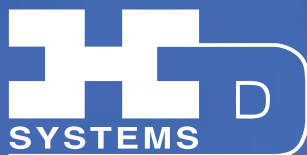
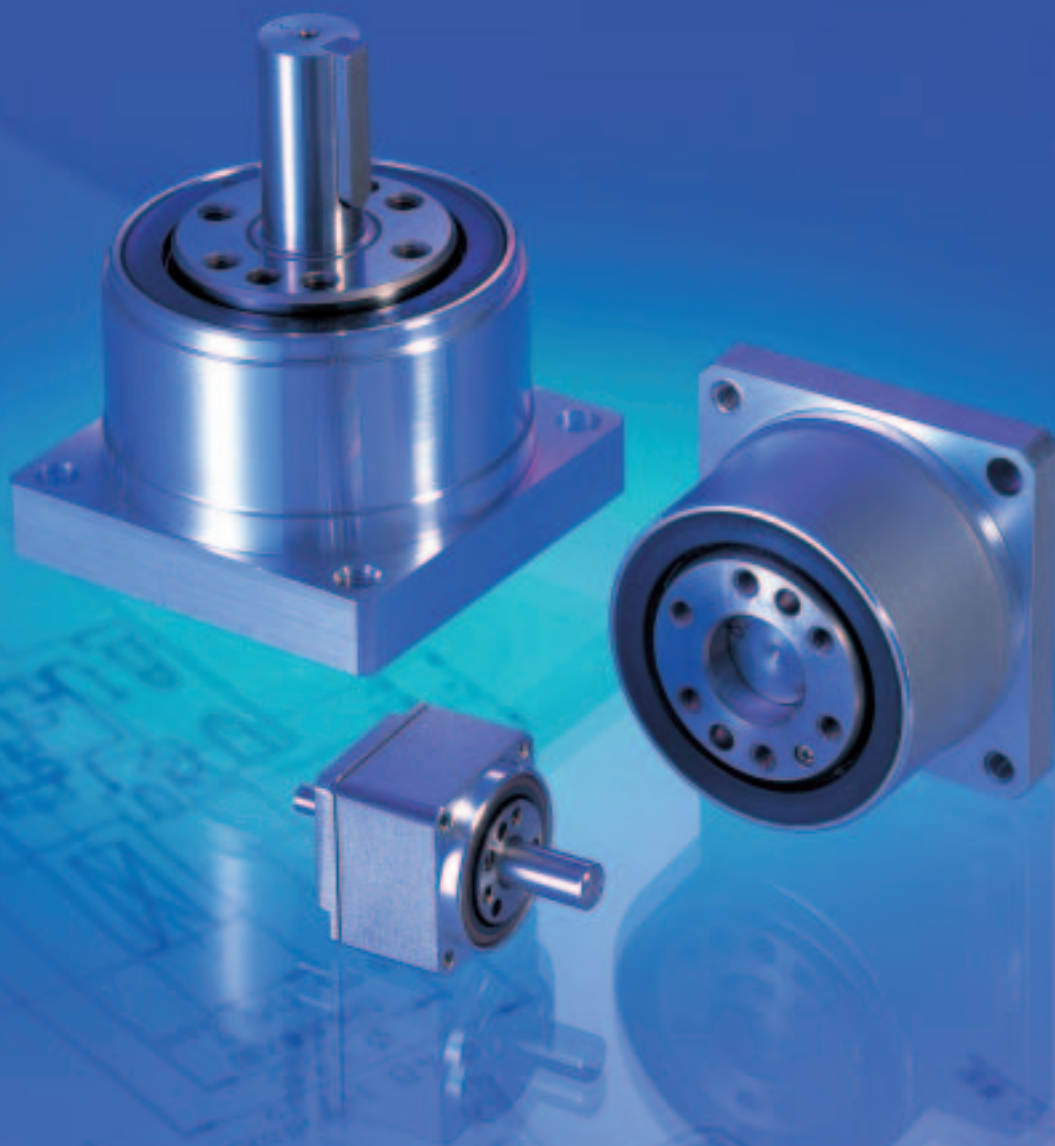

*The Leader in
Precision Motion*

harmonic drive gearing
Precision Gearing & Motion Control

HARMONIC DRIVE GEARING IS THE NEXT GENERATION IN PRECISION MOTION CONTROL

HIGH PERFORMANCE IN A COMPACT PACKAGE

3 MODELS ARE AVAILABLE TO MEET DIVERSE APPLICATIONS

ZERO BACKLASH, HIGH POSITIONAL ACCURACY, HIGH REPEATABILITY

The innovative design of harmonic drive gearing allows consistently high performance over the life of the gear.

COMPACT, LIGHTWEIGHT, HIGH TORQUE CAPACITY

HD Systems' patented "S" gear tooth profile achieves twice the torque, life and torsional stiffness as compared to gears of the same size by allowing up to 30% of the gear teeth to be engaged at all times.

HIGH MOMENT LOAD CAPACITY

The output flange/shaft is supported by a high performance 4 point contact output bearing. This bearing has excellent run-out characteristics and can support high radial, axial, and moment loads.

WIDE RANGE OF GEAR RATIOS AND INPUT/OUTPUT CONFIGURATIONS IN EACH SIZE

Gear Ratios 30:1, 50:1, and 100:1 are available in each size. This allows servomotor and gearhead combinations to operate over a wide speed range. In addition, each size has 3 input/output shaft/flange configurations allowing convenient methods for attaching loads, motors, and pulleys.

Sold & Serviced By:

 Toll Free Phone (877) SERV098
 Toll Free Fax (877) SERV099
www.electromate.com
sales@electromate.com

Output Bearings Ratings

	Bearing Pitch Diameter	Offset	Dynamic Load Rating		Moment Load	Moment Rigidity	Allowable Radial Load	Allowable Axial Load
			Load Rating	Static Load Rating				
	mm	mm	$\times 10^2 \text{N}$	$\times 10^2 \text{N}$	N·m	N·m/rad	N	N
5	13.5	4.85	0.91	0.76	0.89	7.41×10^2	90	270
8	20.5	7.3	2.16	1.9	3.46	2.76×10^3	200	630
11	27.5	9	3.89	3.54	6.6	7.41×10^3	300	1150
14	35	11.4	5.85	5.85	13.2	1.34×10^4	550	1800

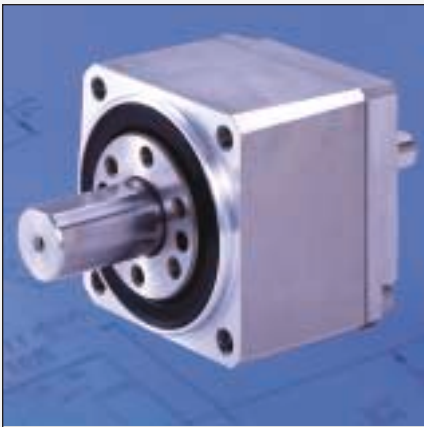

GEARHEAD TYPE 1U

This gearhead is easy to use and has both an input and output shaft. It also allows for pulleys to be used for the input and output to the gearhead.

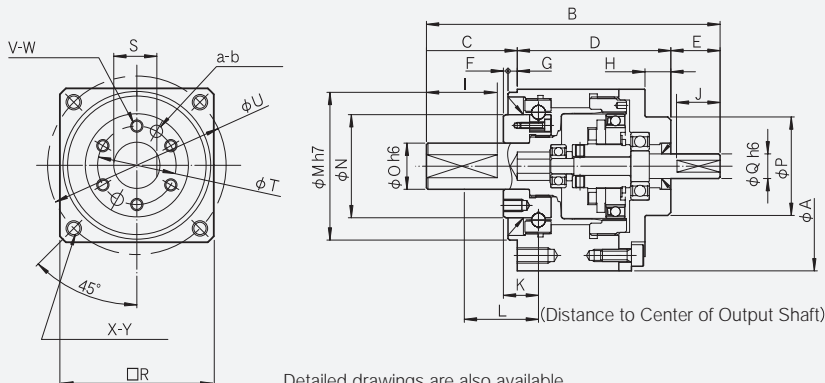

Detailed drawings are also available.

	mm			
	5	8	11	14
ϕA	26.5	40	54	68
B	37	65.5	82.5	95.4
C	13	23	29.5	29.5
D	16	29.5	37	49.9
E	8	13	16	16
F	0.5	0.5	0.5	1.5
G	2.5	2.5	3	3
H	0.8	2.6	3.9	8.4
I	9	18	21.5	23
J	7	11	14	14
K	4.85	7.3	9	11.4
L	9.85	17.3	22	24
ϕM h7	19.5	29	39	48
ϕN	13	20	26.5	33.5
ϕO h6	5	9	12	15
ϕP	9	16	24	32
ϕQ h6	3	5	6	8
$\square R$	20	30	40	50
S	4.6	8	10.5	14
ϕT	9.8	15.5	20.5	25.5
ϕU	23	35	46	58
V	3	4	6	6
W	M2×3	M3×4	M3×5	M4×6
X	4	4	4	4
Y	M2×3	M3×6	M4×8	M5×10
a	3	2	2	2
b	$\phi 2 \times 2.5$	$\phi 3 \times 3$	$\phi 3 \times 4$	$\phi 4 \times 4$
c	2.6	4.5	5.5	7.5
weight (g)	35	130	240	440



GEARHEAD TYPE 2XH-F

This gearhead is designed to be coupled directly to a servomotor. The motor shaft is attached directly to the gearhead input element. The output of the gearhead is a flange.

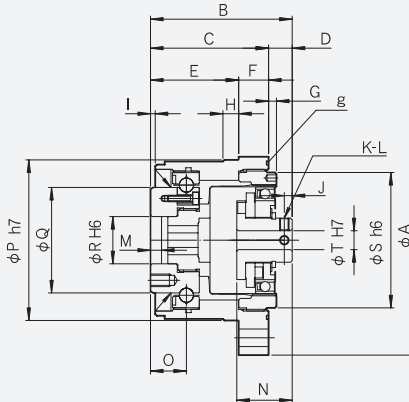
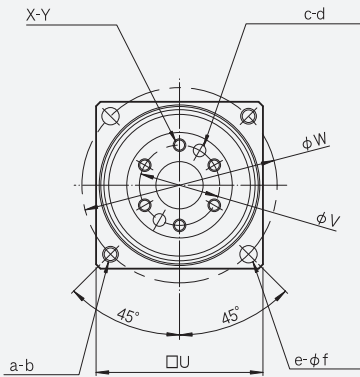

Detailed drawings are also available.

	mm			
	5	8	11	14
φ A	29	43.5	58	73
B	17	28.7	38.3	45
C	15.7	24.5	30	37.5
D	1.3	4.2	8.3	7.5
E	12.7	19	23.5	28
F	3	5.5	6.5	9.5
G	-	1.5	2	2.5
H	2	3	3	5
I	0.5	0.5	0.5	1.5
J	2	2	3	2.5
K	2	2	2	2
L	M2×3	M2×3	M3×4	M3×4
M	1.7	2.2	2.5	3.5
N	6	12	16	17.6
O	4.85	7.3	9	11.4
φ P h7	20.5	31	40.5	51
φ Q	13	20	26.5	33.5
φ R H6	5	9	12	15
φ S h6	17	26	35	43
φ T H7	3	3	5	6
□ U	22	32	43	53
φ V	9.8	15.5	20.5	25.5
φ W	25	37.5	50	62
X	3	4	6	6
Y	M2×3	M3×4	M3×5	M4×6
a	2	2	2	2
b	M2	M3	M4	M5
c	3	2	2	2
d	φ 2×2.5	φ 3×3	φ 3×4	φ 4×4
e	2	2	2	2
φ f	2.3	3.4	4.5	5.5
g	18.90×0.70	28.20×1.00	38.00×1.50	48.00×1.00
weight (g)	25	100	150	295



GEARHEAD TYPE 2XH-J

This gearhead is designed to be coupled directly to a servomotor. The motor shaft is attached directly to the gearhead input element. The output of the gearhead is a shaft.

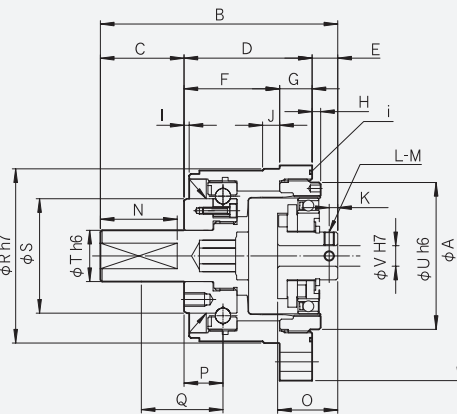
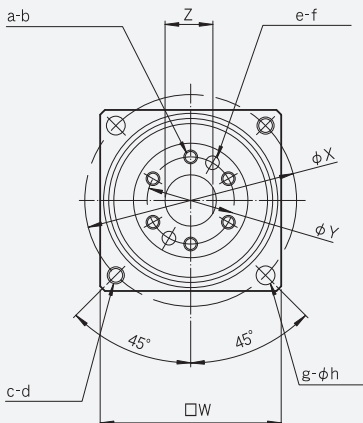

Detailed drawings are also available.

	mm			
	5	8	11	14
φ A	29	43.5	58	73
B	25.7	48.7	64.3	70
C	10	20	26	25
D	15.7	24.5	30	37.5
E	1.3	4.2	8.3	7.5
F	12.7	19	23.5	28
G	3	5.5	6.5	9.5
H	-	1.5	2	2.5
I	0.5	0.5	0.5	1.5
J	2	3	3	5
K	2	2	3	2.5
L	2	2	2	2
M	M2×3	M2×3	M3×4	M3×4
N	9	18	21.5	23
O	6	12	16	17.6
P	4.85	7.3	9	11.4
Q	9.85	17.3	22	23.9
φ R h7	20.5	31	40.5	51
φ S	13	20	26.5	33.5
φ T h6	5	9	12	15
φ U h6	17	26	35	43
φ V H7	3	3	5	6
□ W	22	32	43	53
φ X	25	37.5	50	62
φ Y	9.8	15.5	20.5	25.5
Z	4.6	8	10.5	14
a	3	4	6	6
b	M2×3	M3×4	M3×5	M4×6
c	2	2	2	2
d	M2	M3	M3	M5
e	3	2	2	2
f	φ 2×2.5	φ 3×3	φ 3×4	φ 4×4
g	2	2	2	2
φ h	2.3	3.4	4.5	5.5
i	18.90×0.70	28.20×1.00	38.00×1.00	48.00×1.00
weight (g)	27	111	176	335

Sold & Serviced By:



Toll Free Phone (877) SERV098
 Toll Free Fax (877) SERV099
 www.electromate.com
 sales@electromate.com

RATING TABLE

Size	Ratio	Rated Torque @2000rpm	Repeated Peak Torque	Limit for Average Torque	Momentary Peak Torque	Maximum Input Speed	Average Input Speed	Inertia (@Input Shaft)
		N·m	N·m	N·m	N·m	rpm	rpm	kg·cm ²
5	30	0.25	0.5	0.38	0.9	10000	6500	2.5 × 10 ⁻⁴
	50	0.4	0.9	0.53	1.8			
	100	0.6	1.4	0.94	2.7			
8	30	0.9	1.8	1.4	3.3	8500	3500	3 × 10 ⁻³
	50	1.8	3.3	2.3	6.6			
	100	2.4	4.8	3.3	9			
11	30	2.2	4.5	3.4	8.5	8500	3500	1.2 × 10 ⁻²
	50	3.5	8.3	5.5	17			
	100	5	11	8.9	25			
14	30	4	9	6.8	17	8500	3500	3.3 × 10 ⁻²
	50	5.4	18	6.9	35			
	80	7.8	23	11	47			
	100	7.8	28	11	54			

Allowable Radial Load is based on load acting at the middle of the output shaft for Type 1U and Type 2XH-J

POSITIONAL ACCURACY

$\theta_{er} = \theta_2 - \frac{\theta_1}{R}$
 θ_{er} Positional Accuracy
 θ_1 Input Angle
 θ_2 Output Angle
 R Gear Ratio (i=1:R)

		5	8	11	14
30	10 ⁻⁴ rad	12	5.8	5.8	5.8
	arc min	4	2	2	2
50	10 ⁻⁴ rad	8.8	5.8	4.4	4.4
	arc min	3	2	1.5	1.5
80	10 ⁻⁴ rad	—	—	—	4.4
	arc min	—	—	—	1.5
100	10 ⁻⁴ rad	8.8	5.8	4.4	4.4
	arc min	3	2	1.5	1.5

ORDERING

CSF - 14 - 100 - 2XH - F - SP

Product Size Ratio Configuration Options

	Size	Gear Ratio	Input / Output Configuration	Options
CSF	5	30,50,100	1U: Input Shaft / Output Shaft 2XH-F : Direct Input Coupling / Output Flange 2XH-J : Direct Input Coupling / Output Shaft	Our technical team will be pleased to assist you with special options and ordering codes
	8	30,50,100		
	11	30,50,100		
	14	30,50,80,100		