

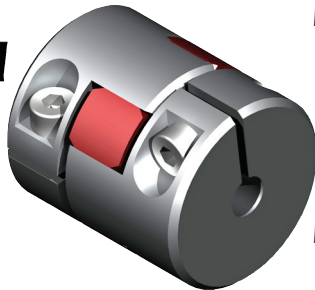

# NEW LOW COST SERVO COUPLING

## ► EKC SERIES ELASTOMER COUPLING



### Major Features

- Low cost elastomer coupling for motion control applications
- Quick standard delivery (same day delivery available)
- Star-shaped elastomer element with involute tooth profile and high shore hardness ensures zero backlash over life of product.
- Elastomer spider compensates for small shaft misalignments.

### Material

- Anodized aluminum hubs and polyurethane 92 Shore A, 98 Shore A, and 72 Shore D spiders available

### Technical data/Dimensions

Coupling Size	Rated Torque* Nm (lb-in)	Elastomer	Elastomer Color	Moment of Inertia 10 <sup>-3</sup> kgm <sup>2</sup> (lb-in <sup>2</sup> )	Torsion Resistance Nm/arcmin (lb-ft/Deg)	Max. Lateral Misalignment mm (inch)	Mass kg (lbs)	Torque to Tighten Screws Nm (lb-in)	Bore Range (D)		Standard Bore Sizes
									min.	max.	
									mm (inch)	mm (inch)	
EKC-5	5 (44)	92 Sh A	Yellow	0.0060 (0.0204)	0.008 (0.35)	0.15 (0.0059)	0.045 (0.1)	5.65 (50)	5 (0.1969)	15 (0.5906)	6, 8, 10, 11, 12, 14 0.25", 0.375", 0.5"
		98 Sh A	Red		0.013 (0.58)	0.09 (0.0035)					
		72 Sh D	White		0.018 (0.81)	0.04 (0.0016)					
EKC-25	25 (221)	92 Sh A	Yellow	0.0407 (0.1390)	0.109 (4.84)	0.1 (0.0039)	0.14 (0.31)	13.00 (115)	8 (0.3150)	20 (0.7874)	10, 11, 12, 14, 16, 19, 20 0.375", 0.5", 0.625", 0.75"
		98 Sh A	Red		0.182 (8.06)	0.06 (0.0024)					
		72 Sh D	White		0.255 (11.29)	0.03 (0.0012)					
EKC-35	35 (310)	92 Sh A	Yellow	0.1667 (0.5696)	0.268 (11.869)	0.14 (0.0055)	0.28 (0.62)	13.00 (115)	13 (0.5118)	28 (1.1024)	14, 16, 19, 20, 24, 28 0.5", 0.625", 0.75", 1"
		98 Sh A	Red		0.447 (19.78)	0.1 (0.0039)					
		72 Sh D	White		0.626 (27.69)	0.05 (0.0020)					
EKC-80	80 (708)	92 Sh A	Yellow	0.3825 (1.3071)	0.346 (15.32)	0.15 (0.0059)	0.53 (1.17)	27.68 (245)	19 (0.7480)	38.1 (1.5)	19, 20, 24, 28, 32, 35 0.75", 1", 1.25", 1.375", 1.5"
		98 Sh A	Red		0.577 (25.53)	0.11 (0.0043)					
		72 Sh D	White		0.808 (35.74)	0.06 (0.0024)					
EKC-110	110 (443)	92 Sh A	Yellow	1.1026 (3.7677)	0.661 (29.25)	0.17 (0.0067)	0.96 (2.12)	27.68 (245)	24 (0.9449)	45 (1.7717)	24, 28, 32, 35, 38, 40 1", 1.25", 1.375", 1.5"
		98 Sh A	Red		1.102 (48.76)	0.12 (0.0047)					
		72 Sh D	White		1.542 (68.26)	0.07 (0.0028)					

\*Higher torques permissible at larger bores

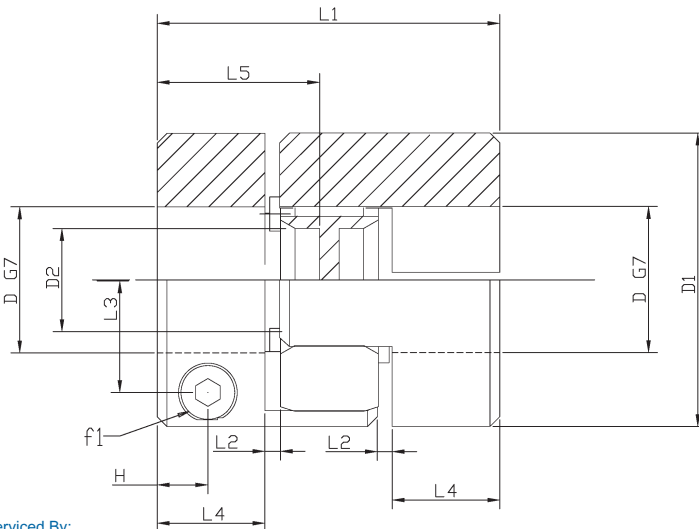

Dimension	EKC-5	EKC-25	EKC-35	EKC-80	EKC-110
	mm (in)	mm (in)	mm (in)	mm (in)	mm (in)
L1: Overall Length	35 (1.38)	66 (2.6)	78 (3.07)	90 (3.54)	114 (4.49)
L2: Gap	1.5 (0.06)	2 (0.08)	2 (0.08)	2.5 (0.10)	3 (0.12)
L3: Radial Bolt Location	10 (0.39)	14.5 (0.57)	20 (0.79)	25 (0.98)	30 (1.18)
L4: Hub Thickness	11 (0.43)	25 (0.98)	30 (1.18)	35 (1.38)	45 (1.77)
L5: Engagement	16.5 (0.65)	31.5 (1.24)	37.5 (1.475)	43 (1.69)	55 (2.165)
D1: Hub OD	30 (1.18)	40 (1.57)	55 (2.17)	65 (2.56)	80 (3.15)
D1*: Overall OD (w/ bolts)	32 (1.26)	45 (1.77)	57 (2.24)	72 (2.83)	83 (3.27)
D2: Elastomer ID	10.5 (0.41)	18 (0.71)	27 (1.06)	30 (1.18)	38 (1.5)
H: Axial Bolt Location	5 (0.2)	11 (0.43)	10.5 (0.41)	11.5 (0.45)	15.5 (0.61)
f1: Screw Size	M4	M6	M6	M8	M8

Red: 98 Shore A

Yellow: 92 Shore A

White: 72 Shore D

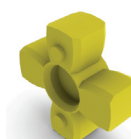
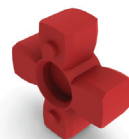

Sold & Serviced By:

**ELECTROMATE**

Toll Free Phone (877) SERV098

Toll Free Fax (877) SERV099

www.electromate.com

sales@electromate.com



# ▶ EKC SERIES ELASTOMER COUPLING

Sample order code:

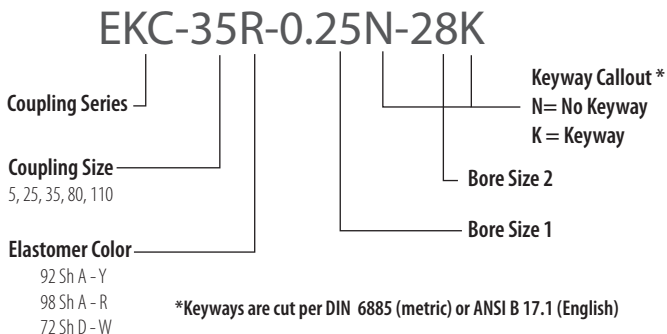

Coupling Size	Price (w/ 2 Standard Bores)	Additional Price per Non-Standard Bore	Additional Price per Keyway
EKC-5	\$34.00	\$6.00	\$6.00
EKC-25	\$40.00	\$6.00	\$6.00
EKC-35	\$59.00	\$6.00	\$6.00
EKC-80	\$78.00	\$7.00	\$7.00
EKC-110	\$86.00	\$7.00	\$7.00

Volume Discounts\*: 10-24: 5% 25+: 10% \*Minimum order value applies

GAM is ranked as one of Inc. Magazine's 2008 top 5000 fastest growing private companies in America

GAM is a leading provider of precision mechanical power transmission components used in the automation of machinery. GAM has a broad product range of gear-reducers, servo-couplings, safety-couplings, and motor mount kits. Our Motto is: BE FLEXIBLE TO MEET OUR CUSTOMERS' REQUESTS AND GIVE GREAT SERVICE. That means, if you can't find exactly what you are looking for in our standard catalog, contact us.

**GAM CAN.  
JUST ASK!**

## OTHER GAM PRODUCTS

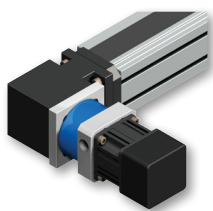

**Linear Slide Kit (LSK):** Customized mounting solution without long lead times

- Customized assembly to mount any motor or gearbox to any linear slide
- Coupling included
- Quick delivery

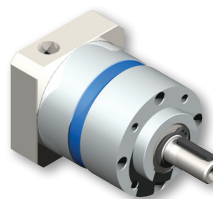

**EPL Series:** Low cost inline planetary gear reducer with custom configurations

- Ratios: 3 – 1000:1
- Frame size: 50 – 150 mm
- Backlash: less than 8 arc minutes
- Efficiencies: 92%

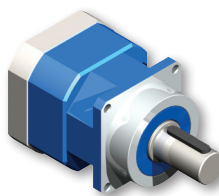

**SPL Series:** Planetary inline gear reducers that pack great performance at a great price

- Ratios: 3 – 100:1
- Frame size: 60 – 180 mm
- Backlash: less than 3 arc minutes
- Efficiencies: 95%

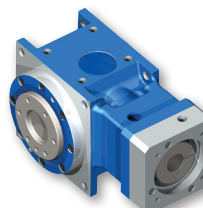

**Dyna Series:** The only right angle hypoid gear reducer up to 15:1 in a single stage

- Ratios: 3 – 150:1
- Frame size: 55 – 190 mm
- Backlash: less than 1 arc minutes
- Efficiencies: up to 96%

For more information about GAM please visit [www.gamweb.com](http://www.gamweb.com)

Sold & Serviced By: **ELECTROMATE**

Toll Free Phone (877) SERV098  
 Toll Free Fax (877) SERV099  
[www.electromate.com](http://www.electromate.com)  
[sales@electromate.com](mailto:sales@electromate.com)