



▶ HIGHEST PERFORMANCE: SPL SERIES

GAM can.

If you don't see exactly what you need, let us know. We can modify the SPL Series gearboxes to meet your needs. Page 4 provides a list of commonly requested modifications to give you a feel for our capabilities.

The SPL is the next generation of our I.M.P.A.C.T.[®] series. It has been designed with the latest servo motors and your most demanding motion control applications in mind. The SPL can handle oversized motor shafts, higher input speeds, and high torques. Now the SPL has been expanded to incorporate our unique Integrated Modular Planetary and Coupling Technology (I.M.P.A.C.T.[®]). Our planetary and coupling package increases system stiffness and reduces the overall costs of conventional packages.

The SPL gearbox performance and quality, along with GAM's manufacturing flexibility and overall service, will provide you with the best solution on the market!

Benefits of the SPL Series include:

- Precision gears equal low backlash with quiet operation
- Long wear life: 30,000 hours
- Lubricated for life
- Ready for motor mounting
- Output dimensions match those of many conventional planetary gearboxes on the market
- Ratios from 3:1 to 100:1
- Frame sizes from 60 mm to 180 mm

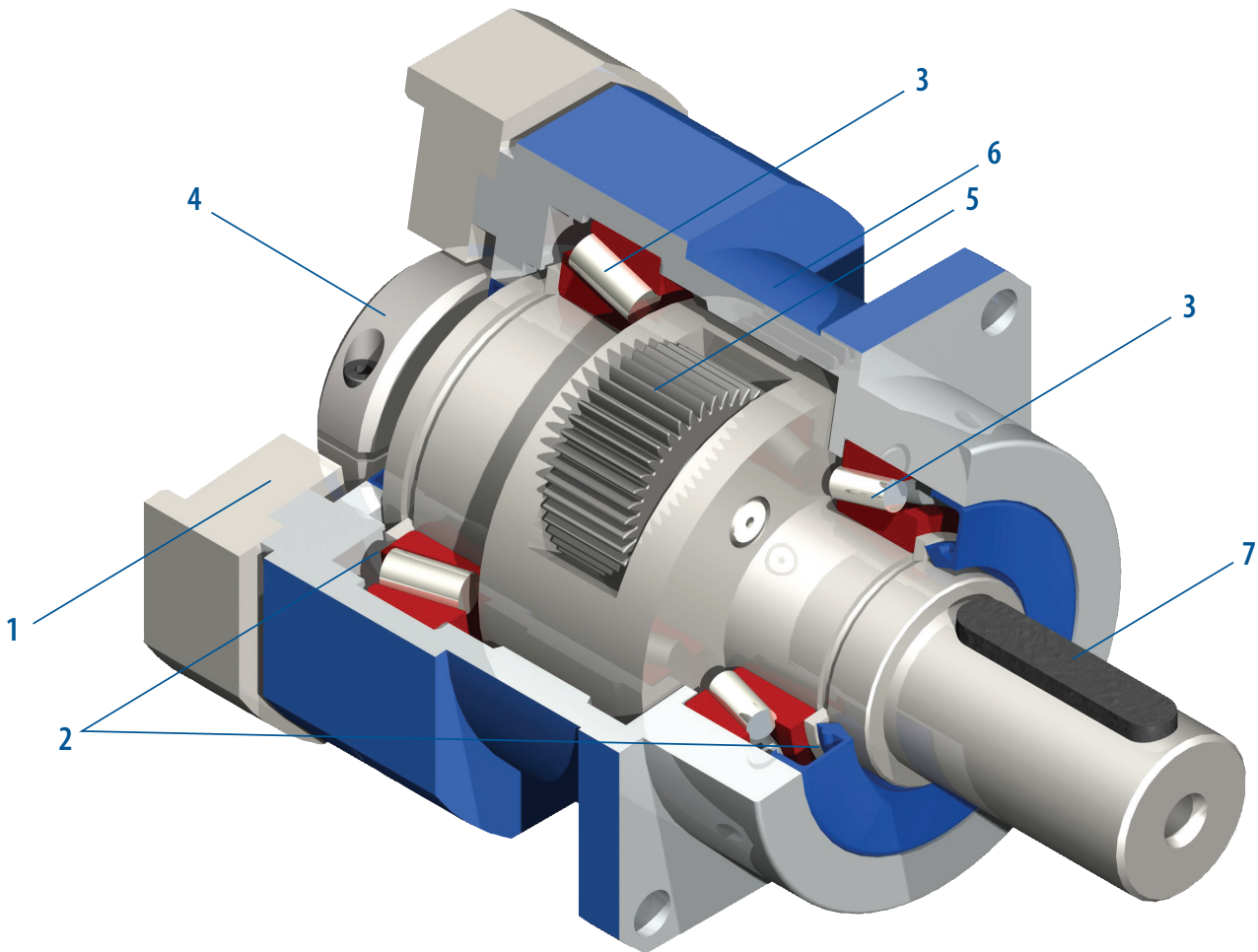

1. Adapter Flange
(Customized adapter flanges for quick and easy motor mounting)
2. Viton[®] Seals
(Protective seals to isolate the gearbox)
3. Bearings
(Tapered roller bearings accommodate high overhung loads)

4. Input Clamping Element
5. Planet Gears
(Extra large face width gears pack a high level of torque in a small gearbox frame)
6. Gear Housing
(Ring gear incorporated into housing)
7. Keyway
(Available with keyway on output shaft)

Sold & Serviced By:

Toll Free Phone (877) SERV098
Toll Free Fax (877) SERV099
www.electromate.com
sales@electromate.com

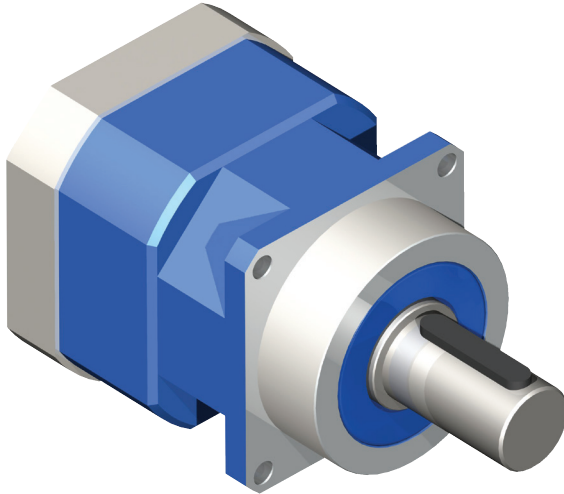
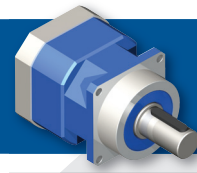

SPL-W

- Shaft output design for mounting to pulleys and rack and pinion systems
- Ratios from 3:1 to 100:1
- Frame sizes from 60 mm to 180 mm (larger sizes available by request)

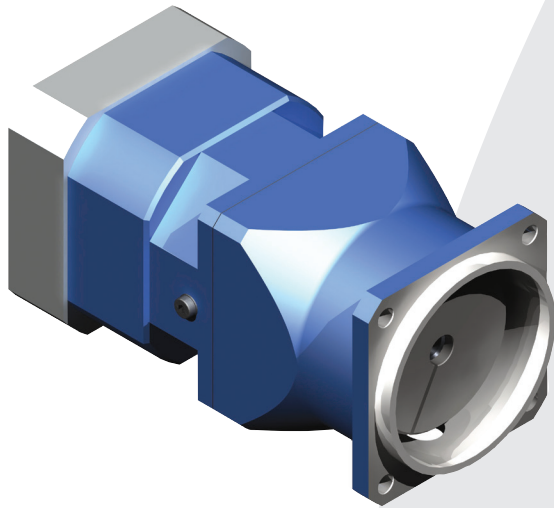

SPL-K

- SPL-KB features a bellows coupling on the output
- Innovative bellow coupling on the output provides for maximum stiffness and best results in high dynamic applications
- Also available with a zero backlash elastomer-spider style coupling (SPL-KE) on the output
- Ratios from 3:1 to 100:1
- Frame sizes from 60 mm to 180 mm
- Output lantern comes standard with the SPL-K
- Custom lanterns available

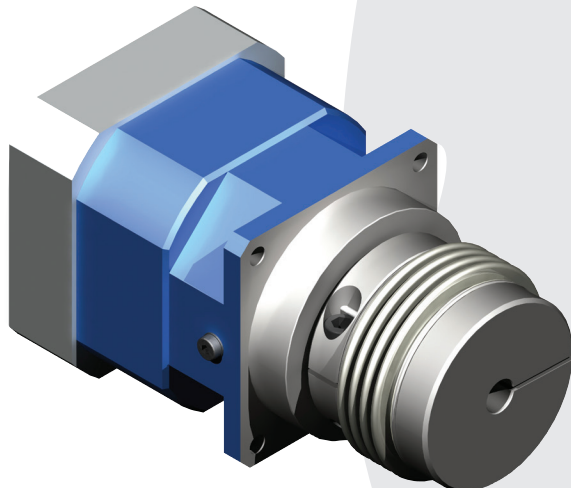

SPL-F

- Same benefits as the SPL-K models without the bell housing on the output. Plug the gearbox into your machine and achieve a more compact design
- Ratios from 3:1 to 100:1
- Frame sizes from 60 mm to 180 mm



SPL SERIES - SPL-W

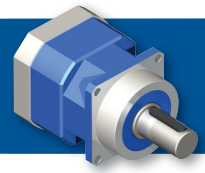

SPL - W			60	75	100	140	180
Stock Ratios			5,10				
All Ratios Available			1 Stage: 3, 4, 5, 7, 10 2 Stage: 12, 16, 20, 25, 35, 40, 50, 70, 100				
Nominal Output Torque (T_{2n})	Nm (lb-in)	3:1	26 (230)	39 (345)	110 (974)	210 (1859)	600 (5310)
		4, 5, 7:1	32 (283)	65 (575)	150 (1328)	340 (3009)	600 (5310)
		10:1	24 (212)	40 (354)	115 (1018)	210 (1859)	600 (5310)
		2-Stage (except 100:1)	38 (336)	85 (752)	180 (1593)	400 (3540)	600 (5310)
		100:1	28 (248)	48 (425)	130 (1151)	250 (2213)	600 (5310)
Max Acceleration Output Torque (T_{2B})	Nm (lb-in)	3:1	36 (319)	80 (708)	180 (1593)	380 (3363)	1200 (10620)
		4, 5, 7:1	50 (443)	120 (1062)	250 (2213)	540 (4779)	1300 (11505)
		10:1	36 (319)	94 (832)	200 (1770)	440 (3894)	1200 (10620)
		2-Stage (except 100:1)	54 (478)	125 (1106)	260 (2301)	550 (4868)	1300 (11505)
		100:1	38 (336)	94 (832)	200 (1770)	440 (3894)	1200 (10620)
Emergency Output Torque (T_{2not})	Nm (lb-in)	3:1	100 (885)	200 (1770)	500 (4425)	1000 (8850)	1850 (16373)
		4, 5, 7:1	120 (1062)	240 (2124)	600 (5310)	1260 (11151)	2450 (21683)
		10:1	90 (797)	200 (1770)	500 (4425)	1000 (8850)	2800 (24780)
		2-Stage (except 100:1)	120 (1062)	240 (2124)	600 (5310)	1260 (11151)	2450 (21683)
		100:1	90 (797)	200 (1770)	500 (4425)	1000 (8850)	2800 (24780)
Nominal Speed (n_{1n})	RPM	-	4500	4500	4000	3800	2000
Max Speed (n_{1max})		-	6500	6000	6000	5500	3500
Standard Output Backlash (j)	arcmin	1-stage	< 6	< 5	< 5	< 5	< 4
		2-stage	< 7	< 6	< 6	< 6	< 6
Reduced Output Backlash (j)	arcmin	1-stage	< 4	< 3	< 3	< 3	< 2
		2-stage	< 5	< 4	< 4	< 4	< 4
Allowable Radial Load (F_{rad}) ¹⁾	N (lbs)	-	3000 (675)	4200 (945)	6300 (1418)	11000 (2475)	13000 (2925)
Allowable Axial Load (F_{axial})	N (lbs)	-	2400 (540)	3800 (855)	5600 (1260)	10600 (2385)	13500 (3038)
Torsional Stiffness (C_{221})	Nm/arcmin (lb-in/arcmin)	1-stage	5 (44)	13 (115)	40 (354)	56 (496)	130 (1151)
		2-stage	5 (44)	13 (115)	40 (354)	56 (496)	130 (1151)
Weight (m)	kg (lbs)	1-stage	2.6 (5.7)	3.7 (8.2)	7.2 (15.9)	19.3 (42.6)	32 (71)
		2-stage	3.3 (7.3)	4.2 (9.3)	9.5 (20.9)	23.3 (51.4)	36.6 (81)
Noise Level (L_{PA})	dB(A)		< 64	< 65	< 67	< 67	< 70
Mass Moment of Inertia (J_1)	kg cm ² (lb-in ²)	3:1	0.43 (0.168)	1.15 (0.450)	6.05 (2.368)	14.25 (5.578)	53 (20.75)
		4:1	0.33 (0.129)	0.92 (0.360)	4.05 (1.585)	9.31 (3.644)	39 (15.27)
		5:1	0.27 (0.106)	0.81 (0.317)	3.17 (1.241)	6.91 (2.705)	34 (13.31)
		7:1	0.23 (0.090)	0.72 (0.282)	2.44 (0.955)	4.91 (1.922)	31 (12.14)
		10:1	0.2 (0.078)	0.67 (0.262)	2.08 (0.814)	3.89 (1.523)	29 (11.35)
Efficiency at Load			1-stage: 96% 2-stage: 94%				
Service Life			> 30,000 hours				
Lubrication			Lifetime lubrication with synthetic oil				
Protection Rating			IP65				
Operating Temperature Range			-20°C to 90°C				

SPL-W

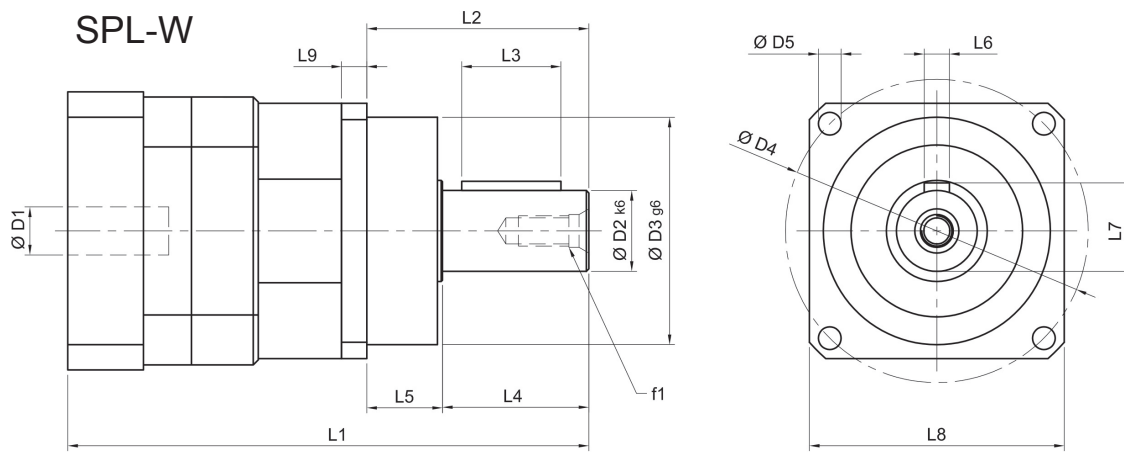

SPL-W		60		75		100		140		180	
		mm	(in)	mm	(in)	mm	(in)	mm	(in)	mm	(in)
D1 max standard	motor shaft diameter	14	(0.551)	19	(0.748)	24	(0.945)	32	(1.260)	54	(2.126)
D1 max available*	motor shaft diameter	19	(0.748)	24	(0.945)	32	(1.26)	38	(1.496)	54	(2.126)
D1 max 2-stage	motor shaft diameter	14	(0.551)	19	(0.748)	24	(0.945)	34	(1.339)	38	(1.496)
D2 k6	output shaft diameter	16	(0.63)	22	(0.866)	32	(1.26)	40	(1.575)	55	(2.165)
D3 g6	pilot diameter	60	(2.362)	70	(2.756)	90	(3.543)	130	(5.118)	160	(6.299)
D4	bolt circle	68	(2.677)	85	(3.346)	120	(4.724)	165	(6.496)	215	(8.465)
f1	shaft thread	M5 x 12		M8 x 19		M12 x 26		M16 x 36		M20 x 42	
D5	mounting holes ø	ø5.5		ø6.6		ø9		ø11		ø13	
L1 1-STAGE**	gearbox total length	151 (5.945)		174.5 (6.87)		226.5 (8.917)		292 (11.496)		312 (12.283)	
L1 2-STAGE**		178 (7.008)		201 (7.913)		251 (9.882)		342 (13.465)		334 (13.15)	
L2	shaft length	48 (1.89)		56 (2.205)		88 (3.465)		112 (4.409)		100 (3.937)	
L3	key length	25 (0.984)		32 (1.26)		50 (1.969)		70 (2.756)		63 (2.756)	
L4	usable shaft length	28 (1.102)		36 (1.417)		58 (2.283)		82 (3.228)		82 (3.228)	
L5	pilot height	20 (0.787)		20 (0.787)		30 (1.181)		30 (1.181)		14 (0.551)	
L6	key width	5 (0.197)		6 (0.236)		10 (0.394)		12 (0.472)		16 (0.630)	
L7	key height	18 (0.709)		24.5 (0.965)		35 (1.378)		43 (1.693)		60 (2.362)	
L8	output square	65 (2.559)		76 (2.992)		101 (3.976)		141 (5.551)		180 (7.087)	
L9	flange thickness	6 (0.236)		7 (0.276)		10 (0.394)		12 (0.472)		14 (0.551)	

* for larger motor shaft diameters, please contact GAM ** depending on the motor, value can vary

TYPE CODES FOR SPL SERIES (SPL-W)

Example: SPL - W - 075 - 005 G - [115 - A01] - S111

Gearbox Series

SPL Series

Gearbox Style

W = Output Shaft

Gearbox Size

060, 075, 100, 140, 180

Ratio

3, 4, 5, 7, 10, 12, 16, 20, 25, 35, 40, 50, 70, 100

Special Options

Assigned by GAM

Motor Mount Kit

Assigned by GAM

Options Available for This Product

G = Key on output shaft per DIN6885

C = Reduced backlash and key on output shaft

H = Smooth output shaft

A = Reduced backlash and smooth shaft

Tolerances (mm)		
Size	k6	g6
Over 6	+0.010	-0.005
Thru 10	+0.001	-0.014
Over 10	+0.012	-0.006
Thru 18	+0.001	-0.017
Over 18	+0.015	-0.007
Thru 30	+0.002	-0.020
Over 30	+0.018	-0.009
Thru 50	+0.002	-0.025
Over 50	+0.021	-0.010
Thru 80	+0.002	-0.029
Over 80	+0.025	-0.012
Thru 120	+0.003	-0.034
Over 120	+0.028	-0.014
Thru 180	+0.003	-0.037

Sold & Serviced By:

ELECTROMATE

Toll Free Phone (877) SERV098

Toll Free Fax (877) SERV099

www.electromate.com

sales@electromate.com



SPL SERIES - SPL-K

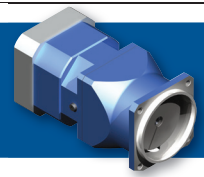

SPL-K		60	75	100	140	180	
Stock Ratios		5,10					
All Ratios Available		1 Stage: 3, 4, 5, 7, 10 2 Stage: 12, 16, 20, 25, 35, 40, 50, 70, 100					
Nominal Output Torque (T_{2n})	Nm (lb-in)	3:1	26 (230)	39 (345)	110 (974)	210 (1859)	600 (5310)
		4, 5, 7:1	32 (283)	65 (575)	150 (1328)	340 (3009)	600 (5310)
		10:1	24 (212)	40 (354)	115 (1018)	210 (1859)	600 (5310)
		2-Stage (except 100:1)	38 (336)	85 (752)	180 (1593)	400 (3540)	600 (5310)
		100:1	28 (248)	48 (425)	130 (1151)	250 (2213)	600 (5310)
Max Acceleration Output Torque (T_{2B})	Nm (lb-in)	3:1	36 (319)	80 (708)	180 (1593)	380 (3363)	1200 (10620)
		4, 5, 7:1	50 (443)	120 (1062)	250 (2213)	540 (4779)	1300 (11505)
		10:1	36 (319)	94 (832)	200 (1770)	440 (3894)	1200 (10620)
		2-Stage (except 100:1)	54 (478)	125 (1106)	260 (2301)	550 (4868)	1300 (11505)
		100:1	38 (336)	94 (832)	200 (1770)	440 (3894)	1200 (10620)
Emergency Output Torque (T_{2not})	Nm (lb-in)	3:1	100 (885)	200 (1770)	500 (4425)	1000 (8850)	1850 (16373)
		4, 5, 7:1	120 (1062)	240 (2124)	600 (5310)	1260 (11151)	2450 (21683)
		10:1	90 (797)	200 (1770)	500 (4425)	1000 (8850)	2800 (24780)
		2-Stage (except 100:1)	120 (1062)	240 (2124)	600 (5310)	1260 (11151)	2450 (21683)
		100:1	90 (797)	200 (1770)	500 (4425)	1000 (8850)	2800 (24780)
Nominal Speed (n_{1n})	RPM	-	4500	4500	4000	3800	2000
Max Speed (n_{1max})		-	6500	6000	6000	5500	3500
Standard Output Backlash (j)	arcmin	1-stage	< 6	< 5	< 5	< 5	< 4
		2-stage	< 7	< 6	< 6	< 6	< 6
Reduced Output Backlash (j)	arcmin	1-stage	< 4	< 3	< 3	< 3	< 2
		2-stage	< 5	< 4	< 4	< 4	< 4
Torsional Stiffness (C_{21})	Nm/arcmin (lb-in/arcmin)	1-stage	3.21 (28.4)	7.88 (69.7)	22.61 (200.1)	36.64 (324.3)	36.6 (324.3)
		2-stage	3.21 (28.4)	7.88 (69.7)	22.61 (200.1)	36.64 (324.3)	36.6 (324.3)
Weight (m)	kg (lbs)	1-stage	3.35 (7.39)	4.61 (10.16)	9.82 (21.65)	24.55 (54.12)	38.4 (84.7)
		2-stage	4.05 (8.93)	5.11 (11.27)	12.12 (26.72)	28.55 (62.94)	43 (94.8)
Noise Level (L_{pA})	dB(A)		< 64	< 65	< 67	< 67	< 70
Mass Moment of Inertia (J_1)	kg cm ² (lb-in ²)	3:1	0.65 (0.223)	2.82 (0.962)	10.11 (3.454)	21.31 (7.283)	53 (18.090)
		4:1	0.54 (0.185)	2.41 (0.822)	6.87 (2.346)	13.79 (4.711)	39 (13.310)
		5:1	0.49 (0.168)	2.23 (0.762)	5.41 (1.848)	10.2 (3.486)	39 (13.310)
		7:1	0.44 (0.150)	2.06 (0.704)	4.18 (1.428)	7.15 (2.444)	31 (10.580)
		10:1	0.42 (0.143)	1.98 (0.678)	3.55 (1.213)	5.59 (1.910)	31 (10.580)
Efficiency at Load	1-stage: 96% 2-stage: 94%						
Service Life	> 30,000 hours						
Lubrication	Lifetime lubrication with synthetic oil						
Protection Rating	IP65						
Operating Temperature Range	-20°C to 90°C						

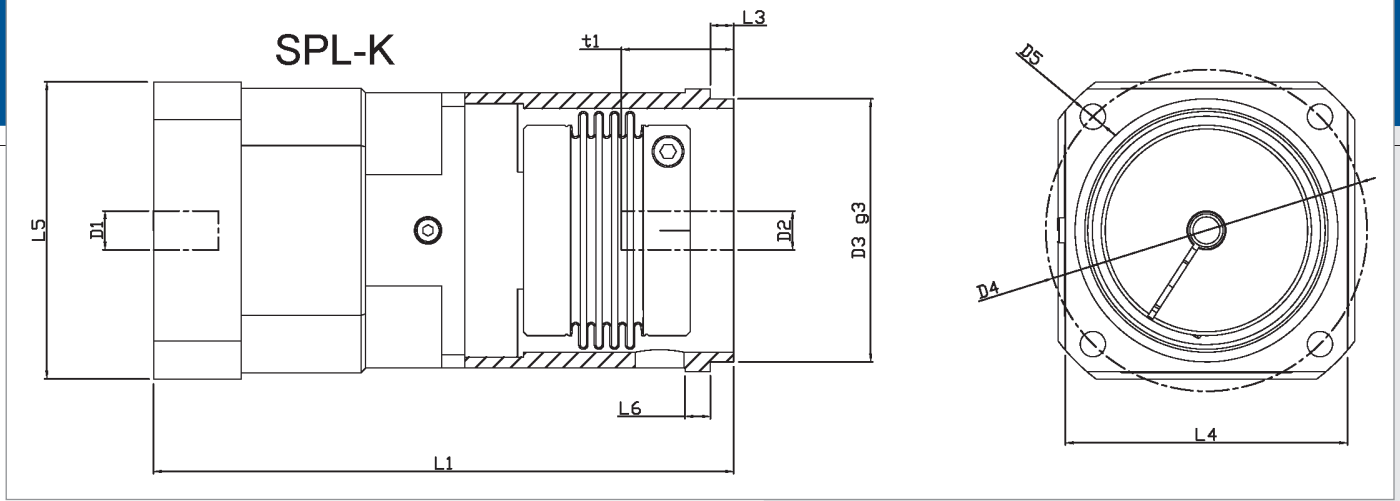

SPL-K		60		75		100		140		180	
		mm	(in)	mm	(in)	mm	(in)	mm	(in)	mm	(in)
D1 max standard	motor shaft diameter	14	(0.551)	19	(0.748)	24	(0.945)	32	(1.260)	54	(2.126)
D1 max available*	motor shaft diameter	19	(0.748)	24	(0.945)	32	(1.26)	38	(1.496)	54	(2.126)
D1 max 2-stage	motor shaft diameter	14	(0.551)	19	(0.748)	24	(0.945)	34	(1.339)	38	(1.496)
D2 _{max-KB}	max output bore	28	(1.102)	38	(1.496)	50	(1.969)	64	(2.520)	85	(3.346)
D2 _{max-KE}	max output bore	26	(1.024)	38	(1.496)	46	(1.811)	56	(2.205)	-	-
D3 _{g6-KB/E}	pilot diameter	70	(2.756)	85	(3.346)	115	(4.528)	135	(5.315)	180	(7.087)
D4 _{KB/E}	bolt circle	85	(3.346)	105	(4.134)	140	(5.512)	165	(6.496)	215	(8.465)
D5 _{KB/E}	bolt hole	6.6	(0.26)	9	(0.354)	11	(0.433)	13	(0.512)	17	(0.669)
L1 _{1-stage KB/E**}	gearbox total length	180	(7.087)	207	(8.150)	241.5	(9.508)	300	(11.811)	326	(12.835)
L1 _{2-stage KB/E**}	gearbox total length	207	(8.150)	233.5	(9.193)	266	(10.472)	350	(13.780)	340	(13.386)
L3 _{KB/E}	pilot height	6	(0.236)	8	(0.315)	10	(0.394)	12	(0.472)	15	(0.591)
L4 _{KB/E}	output flange size	70	(2.756)	95	(3.74)	120	(4.724)	145	(5.709)	190	(7.48)
L5**	gearbox thickness	70	(2.756)	81	(3.189)	106	(4.173)	146	(5.748)	200	(7.874)
L6 _{KB/E}	flange thickness	7	(0.276)	9	(0.354)	11	(0.433)	13	(0.512)	15	(0.591)
t1 _{min-KB}	min shaft engagement	21	(0.827)	26	(1.024)	32	(1.260)	33	(1.300)	59	(2.323)
t1 _{max-KB}	max shaft engagement	43	(1.693)	58.5	(2.3031)	60	(2.362)	68	(2.677)	88	(3.465)
t1 _{min-KE}	min shaft engagement	22	(0.866)	28	(1.102)	34	(1.339)	36	(1.417)	-	-
t1 _{max-KE}	max shaft engagement	31.5	(1.240)	38.5	(1.516)	45	(1.772)	48.5	(1.909)	-	-

* for larger motor shaft diameters, please contact GAM ** depending on the motor, value can vary

TYPE CODES FOR SPL-K SERIES

Example: SPL - KE - 060 - 005 G - [115-201] - S111

Gearbox Series

SPL Series

Gearbox Style

KB = Bellows coupling output
KE = Elastomer coupling output

Gearbox Size

060, 075, 100, 140, 180

Ratio

3, 4, 5, 7, 10, 12, 16, 20, 25, 35, 40, 50, 70, 100

Special Options

Assigned by GAM

Motor Mount Kit

Assigned by GAM

Options Available for This Product

- G = Standard backlash and keyway in output coupling
- C = Reduced backlash and keyway in output coupling
- H = Standard backlash and no keyway in output coupling
- A = Reduced backlash and no keyway in output coupling

Tolerances (mm)

Size	k6	g6
Over 6	+0.010	-0.005
Thru 10	+0.001	-0.014
Over 10	+0.012	-0.006
Thru 18	+0.001	-0.017
Over 18	+0.015	-0.007
Thru 30	+0.002	-0.020
Over 30	+0.018	-0.009
Thru 50	+0.002	-0.025
Over 50	+0.021	-0.010
Thru 80	+0.002	-0.029
Over 80	+0.025	-0.012
Thru 120	+0.003	-0.034
Over 120	+0.028	-0.014
Thru 180	+0.003	-0.037

Sold & Serviced By:

ELECTROMATE
Toll Free Phone (877) SERV098
Toll Free Fax (877) SERV099
www.electromate.com
sales@electromate.com



SPL SERIES - SPL-F

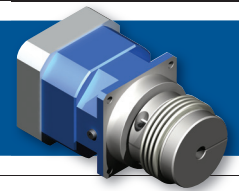

SPL-F			60	75	100	140	180	
Stock Ratios			5,10					
All Ratios Available			1 Stage: 3, 4, 5, 7, 10 2 Stage: 12, 16, 20, 25, 35, 40, 50, 70, 100					
Nominal Output Torque (T_{2n})	Nm (lb-in)	3:1	26 (230)	39 (345)	110 (974)	210 (1859)	600 (5310)	
		4, 5, 7:1	32 (283)	65 (575)	150 (1328)	340 (3009)	600 (5310)	
		10:1	24 (212)	40 (354)	115 (1018)	210 (1859)	600 (5310)	
		2-Stage (except 100:1)	38 (336)	85 (752)	180 (1593)	400 (3540)	600 (5310)	
		100:1	28 (248)	48 (425)	130 (1151)	250 (2213)	600 (5310)	
Max Acceleration Output Torque (T_{2B})	Nm (lb-in)	3:1	36 (319)	80 (708)	180 (1593)	380 (3363)	1200 (10620)	
		4, 5, 7:1	50 (443)	120 (1062)	250 (2213)	540 (4779)	1300 (11505)	
		10:1	36 (319)	94 (832)	200 (1770)	440 (3894)	1200 (10620)	
		2-Stage (except 100:1)	54 (478)	125 (1106)	260 (2301)	550 (4868)	1300 (11505)	
		100:1	38 (336)	94 (832)	200 (1770)	440 (3894)	1200 (10620)	
Emergency Output Torque (T_{2not})	Nm (lb-in)	3:1	100 (885)	200 (1770)	500 (4425)	1000 (8850)	1850 (16373)	
		4, 5, 7:1	120 (1062)	240 (2124)	600 (5310)	1260 (11151)	2450 (21683)	
		10:1	90 (797)	200 (1770)	500 (4425)	1000 (8850)	2800 (24780)	
		2-Stage (except 100:1)	120 (1062)	240 (2124)	600 (5310)	1260 (11151)	2450 (21683)	
		100:1	90 (797)	200 (1770)	500 (4425)	1000 (8850)	2800 (24780)	
Nominal Speed (n_{1n})	RPM	-	4500	4500	4000	3800	2000	
Max Speed (n_{1max})		-	6500	6000	6000	5500	3500	
Standard Output Backlash (j)	arcmin	1-stage	< 6	< 5	< 5	< 5	< 4	
		2-stage	< 7	< 6	< 6	< 6	< 6	
Reduced Output Backlash (j)	arcmin	1-stage	< 4	< 3	< 3	< 3	< 2	
		2-stage	< 5	< 4	< 4	< 4	< 4	
Torsional Stiffness (C_{21})	Nm/arcmin (lb-in/arcmin)	1-stage	3.21 (28.4)	7.88 (69.7)	22.61 (200.1)	36.64 (324.3)	36.6 (324.3)	
		2-stage	3.21 (28.4)	7.88 (69.7)	22.61 (200.1)	36.64 (324.3)	36.6 (324.3)	
Weight (m)	kg (lbs)	1-stage	3.1 (6.8)	4.2 (9.3)	8.7 (19.2)	22.7 (50.1)	32.8 (72.3)	
		2-stage	3.8 (8.4)	4.7 (10.4)	11 (24.2)	26.7 (58.9)	37.4 (82.5)	
Noise Level (L_{pA})	dB(A)		< 64	< 65	< 67	< 67	< 70	
Mass Moment of Inertia (J_1)	kg cm ² (lb-in ²)	3:1	0.65 (0.223)	2.82 (0.962)	10.11 (3.454)	21.31 (7.283)	53 (18.090)	
		4:1	0.54 (0.185)	2.41 (0.822)	6.87 (2.346)	13.79 (4.711)	39 (13.310)	
		5:1	0.49 (0.168)	2.23 (0.762)	5.41 (1.848)	10.2 (3.486)	39 (13.310)	
		7:1	0.44 (0.150)	2.06 (0.704)	4.18 (1.428)	7.15 (2.444)	31 (10.580)	
		10:1	0.42 (0.143)	1.98 (0.678)	3.55 (1.213)	5.59 (1.910)	31 (10.580)	
Efficiency at Load		1-stage: 96% 2-stage: 94%						
Service Life		> 30,000 hours						
Lubrication		Lifetime lubrication with synthetic oil						
Protection Rating		IP65						
Operating Temperature Range		-20°C to 90°C						

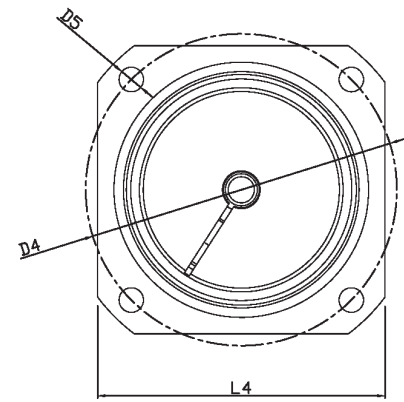
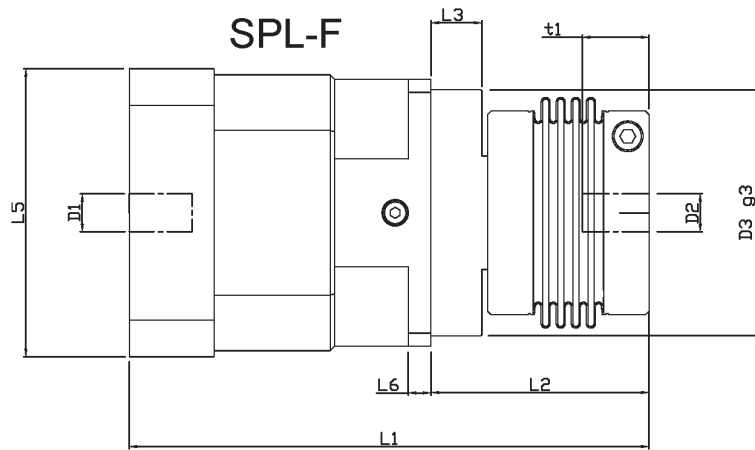

SPL-F		60		75		100		140		180	
		mm	(in)	mm	(in)	mm	(in)	mm	(in)	mm	(in)
D1 max standard	motor shaft diameter	14	(0.551)	19	(0.748)	24	(0.945)	32	(1.260)	54	(2.126)
D1 max available*	motor shaft diameter	19	(0.748)	24	(0.945)	32	(1.26)	38	(1.496)	54	(2.126)
D1 max 2-stage	motor shaft diameter	14	(0.551)	19	(0.748)	24	(0.945)	34	(1.339)	38	(1.496)
D2 _{max-FB}	max output bore	28	(1.102)	38	(1.496)	50	(1.969)	64	(2.520)	85	(3.346)
D2 _{max-FE}	max output bore	26	(1.024)	38	(1.496)	46	(1.811)	56	(2.205)	-	-
D3 _{g6-FB/E}	pilot diameter	60	(2.362)	70	(2.756)	90	(3.543)	130	(5.118)	160	(6.299)
D4 _{FB/E}	bolt circle	68	(2.677)	85	(3.346)	120	(4.724)	165	(6.496)	215	(8.465)
D5 _{FB/E}	bolt hole	ø5.5		ø6.6		ø9		ø11		ø13	
L1 _{1-stage-FB**}	gearbox total length	169	(6.653)	196.5	(7.736)	223	(8.779)	280	(11.024)	304	(11.968)
L1 _{2-stage-FB**}	gearbox total length	196	(7.716)	223	(8.779)	247.5	(9.744)	330	(12.992)	327	(12.874)
L1 _{1-stage-FE**}	gearbox total length	171	(6.732)	196.5	(7.736)	226.5	(8.917)	290	(11.417)	-	-
L1 _{2-stage-FE**}	gearbox total length	198	(7.795)	223	(8.779)	251	(9.882)	340	(13.386)	-	-
L2 _{FB}	coupling length	76	(2.992)	83	(2.047)	105	(4.134)	117	(4.606)	112	(4.409)
L2 _{FE}	coupling length	79	(3.110)	94	(3.700)	104	(4.094)	125	(4.921)	-	-
L3 _{FB/E}	pilot height	20	(0.787)	20	(0.787)	30	(1.181)	30	(1.181)	14	(0.551)
L4 _{FB/E}	output flange size	65	(2.559)	76	(2.992)	101	(3.976)	141	(5.551)	180	(7.087)
L5**	gearbox thickness	70	(2.756)	81	(3.189)	106	(4.173)	146	(5.748)	200	(7.874)
L6 _{FB/E}	flange thickness	6	(0.236)	7	(0.276)	10	(0.394)	12	(0.472)	20	(0.787)
t1 _{min-FB}	min shaft engagement	21	(0.827)	26	(1.024)	32	(1.260)	33	(1.300)	59	(2.323)
t1 _{max-FB}	max shaft engagement	39	(1.535)	43	(1.693)	58	(2.165)	52	(2.047)	88	(3.465)
t1 _{min-FE}	min shaft engagement	22	(0.866)	28	(1.102)	34	(1.339)	36	(1.417)	-	-
t1 _{max-FE}	max shaft engagement	31.5	(1.240)	38.5	(1.516)	45	(1.772)	48.5	(1.909)	-	-

* for larger motor shaft diameters, please contact GAM ** depending on the motor, value can vary

TYPE CODES FOR SPL-F SERIES

Example: SPL - FE - 060 - 005 G - [115-201] - S111

Gearbox Series

SPL Series.

Gearbox Style

FB = Bellows coupling output
FE = Elastomer coupling output

Gearbox Size

060, 075, 100, 140, 180

Ratio

3, 4, 5, 7, 10, 12, 16, 20, 25, 35, 40, 50, 70, 100

Special Options

Assigned by GAM

Motor Mount Kit

Assigned by GAM

Options Available for This Product

- G = Standard backlash and keyway in output coupling
- C = Reduced backlash and keyway in output coupling
- H = Standard backlash and no keyway in output coupling
- A = Reduced backlash and no keyway in output coupling

Tolerances (mm)

Size	k6	g6
Over 6	+0.010	-0.005
Thru 10	+0.001	-0.014
Over 10	+0.012	-0.006
Thru 18	+0.001	-0.017
Over 18	+0.015	-0.007
Thru 30	+0.002	-0.020
Over 30	+0.018	-0.009
Thru 50	+0.002	-0.025
Over 50	+0.021	-0.010
Thru 80	+0.002	-0.029
Over 80	+0.025	-0.012
Thru 120	+0.002	-0.034
Over 120	+0.028	-0.014
Thru 180	+0.003	-0.037