

SPH Series

Helical Performance Redefined



GAM

GAM Can. Just Ask.

Sold & Serviced By:
 **ELECTROMATE**

Toll Free Phone (877) SERV098
Toll Free Fax (877) SERV099
www.electromate.com
sales@electromate.com



SPH Series

The SPH series features helical gearing which brings a whole new level of power and precision to GAM's already extensive portfolio of gear reducer technology. With special attention paid to every aspect during development, the SPH gracefully combines design and engineering, to deliver our best inline planetary gear reducer yet. For dynamic and demanding servo applications where performance is critical, the SPH is highly powerful and efficient, yet smooth and quiet.

- 1. Helical Gears** Precision cut and ground to quietly deliver higher torques and accuracies
- 2. Adapter Flange** Custom machined to match any motor for easy installation
- 3. Input Clamping Element** Low inertia and balanced for high speeds with a single tangential screw ensures a secure motor connection
- 4. Bearings** Optimized taper roller bearings to accommodate high radial and axial loads
- 5. Housing** Sleek and contoured steel housing with black oxide treatment for maximum durability
- 6. Ring Gear** Machined directly into the single piece housing for maximum stiffness
- 7. Output Shaft** Offered smooth or keyed and can be easily shortened if required

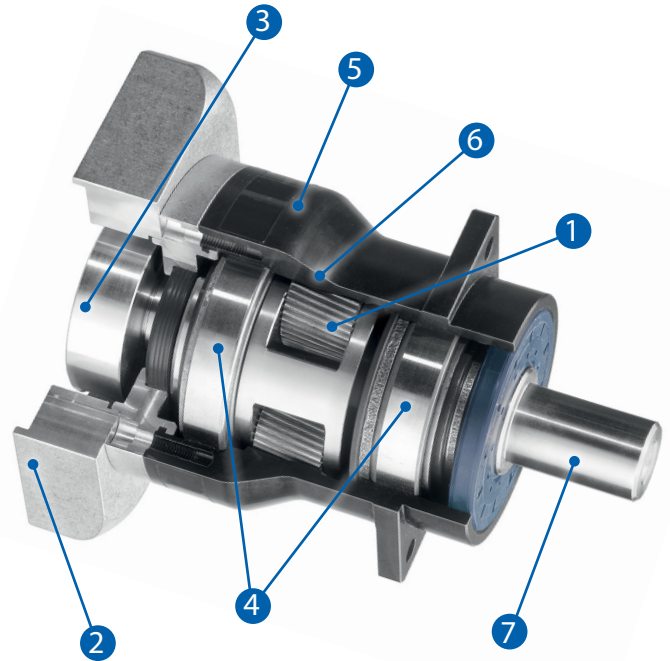

Available configurations for simple and compact machine integration

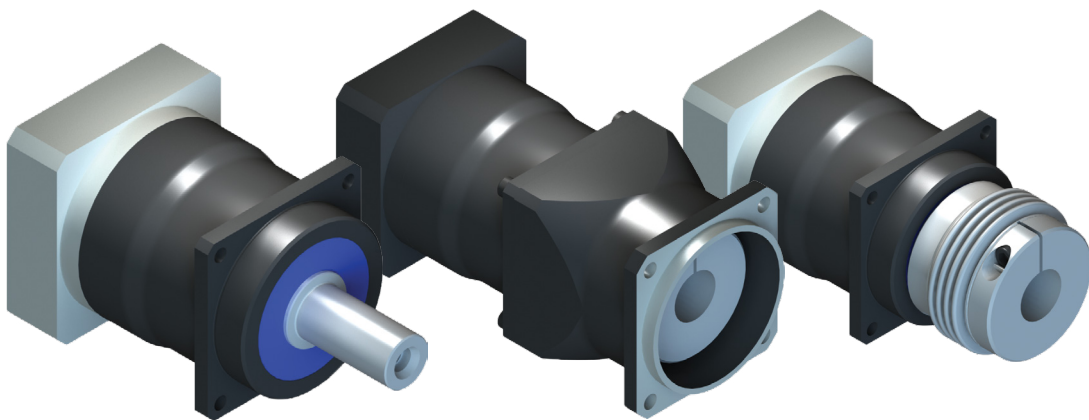

SPH-W

Shaft output design for mounting to pulleys and rack and pinion systems. Available with a smooth or keyed output shaft.

SPH-K

Features a bellows or a zero backlash elastomer-spider coupling on the output for maximum stiffness and the best results in highly dynamic applications. An output housing comes standard with custom housings available.

SPH-F

Same benefits as the SPH-K models without the housing on the output. Plug the gearbox directly into your machine and achieve a more compact design.

Sold & Serviced By:

ELECTROMATE

Toll Free Phone (877) SERV098

Toll Free Fax (877) SERV099

www.electromate.com

sales@electromate.com

When your application is demanding...demand GAM's SPH

	LOW	HIGH	SUPERIOR	WHY GAM SPH?
Flexibility	Competition A		SPH	Configured to meet the application, not the other way around!
	Competition B			
Modifications & Customizations	Competition A		SPH	Flexible manufacturing and experienced engineering
	Competition B			
Performance			SPH	95 years of gear manufacturing experience
			Competition A	
			Competition B	
Quality			SPH	State of the art testing and measuring machines. ISO 9001 certified
			Competition A	
			Competition B	

The SPH is GAM's highest performing inline gear reducer

Designed for **dynamic** & **cyclic** applications

Can be optimized for **high speed** and **continuous** applications

Helical gears make the difference

The helical gear profile is cut at an angle that allows for gradual tooth engagement allowing for smooth, accurate, and quiet transmission. GAM's SPH gears are cut at the optimal helix angle to minimize resultant axial forces and they have a larger tooth width to maximize torque carrying capacity compared to the competition.

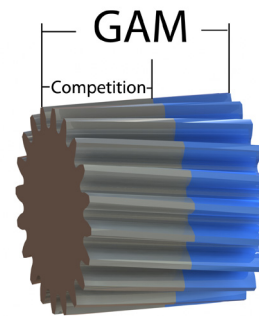

It all starts with the gears

The SPH's helical gears are produced to an extremely high level of quality and ground for further precision. With state of the art testing and measuring instruments and qualified personnel, we assure that the SPH will meet and exceed your requirements. With the SPH, every detail counts.



The following methods are applied:

- CNC coordinate measurement method
- CNC gear measurement method
- Mechanical measurement test
- Surface testing
- Thickness measurement
- Magnetic particle inspection
- Hardness testing
- Grinding burn inspection

Technical Specifications

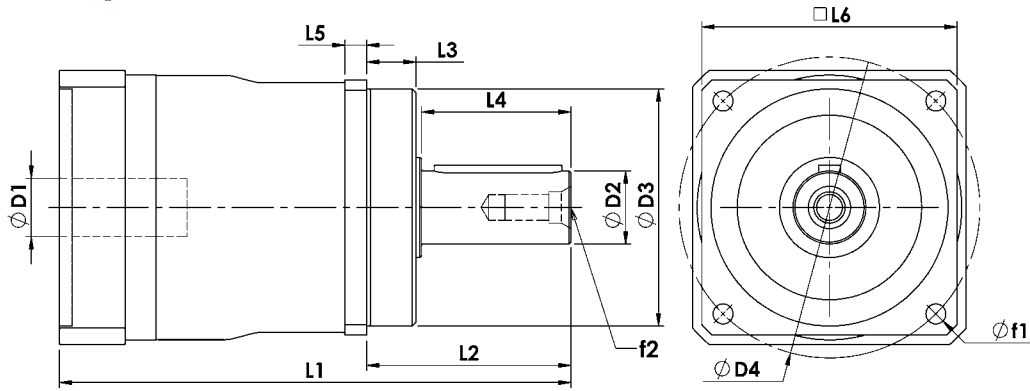

SPH-W		50		60		75		100		140		180	
		mm	(in)	mm	(in)	mm	(in)	mm	(in)	mm	(in)	mm	(in)
D1 _{max} Standard	Motor Shaft Diameter	11	(0.433)	14	(0.551)	19	(0.748)	24	(0.945)	32	(1.260)	38	(1.496)
D1 _{max} Available ¹⁾		11	(0.433)	19	(0.748)	24	(0.945)	32	(1.260)	38	(1.496)	48	(1.890)
D1 _{max} 2-stage		11	(0.433)	14	(0.551)	19	(0.748)	24	(0.945)	32	(1.260)	38	(1.496)
D2 k6	Output Shaft Diameter	14	(0.551)	16	(0.630)	22	(0.866)	32	(1.260)	40	(1.575)	55	(2.165)
D3 g6	Pilot Diameter	45	(1.772)	60	(2.362)	70	(2.756)	90	(3.543)	130	(5.118)	160	(6.299)
D4	Output Bolt Circle	63	(2.480)	68	(2.677)	85	(3.346)	120	(4.724)	165	(6.496)	215	(8.465)
f1	Mounting Holes	5.5	(0.217)	6	(0.236)	6.6	(0.260)	9	(0.354)	11	(0.433)	13	(0.512)
f2	Shaft End Thread	M5		M5		M8		M8		M16		M20	
L1 ²⁾	Overall Gearbox Length	125	(4.921)	150	(5.906)	165	(6.496)	220	(8.661)	280	(11.024)	330	(12.992)
L1 2-stage ²⁾		165	(6.496)	190	(7.480)	210	(8.268)	270	(10.630)	345	(13.583)	420	(16.535)
L2	Shaft Length	38	(1.496)	48	(1.890)	56	(2.205)	88	(3.465)	112	(4.409)	112	(4.409)
L3	Pilot Height	12	(0.472)	18	(0.709)	18	(0.709)	28	(1.102)	27	(1.063)	27	(1.063)
L4	Usable Shaft Length	24	(0.945)	28	(1.102)	36	(1.417)	58	(2.283)	82	(3.228)	85	(3.346)
L5	Flange Thickness	6	(0.236)	6	(0.236)	7	(0.276)	10	(0.394)	12	(0.472)	18	(0.709)
L6	Output Square	55	(2.165)	61	(2.402)	75	(2.953)	100	(3.937)	140	(5.512)	180	(7.087)

1) For larger motor shaft diameters, please contact GAM. 2) Depending on the motor, value can vary.

SPH-W		50	60	75	100	140	180	
Stock Ratios ²⁾		5, 10						
All Ratios Available		1 Stage: 3, 4, 5, 7, 10						
		2 Stage: 12, 15, 16, 20, 25, 28, 30, 35, 40, 50, 70, 100						
Nominal Output Torque (T _{2n})	Nm (lb-in)	3:1-5:1	20 (177)	60 (531)	100 (885)	250 (2213)	450 (3983)	900 (7966)
		7:1	18 (159)	40 (354)	80 (708)	180 (1593)	420 (3717)	800 (7081)
		10:1	15 (133)	30 (266)	65 (575)	110 (974)	240 (2124)	450 (3983)
		12:1-40:1	13 (115)	60 (531)	100 (885)	250 (2213)	450 (3983)	900 (7966)
		50:1	13 (115)	40 (354)	80 (708)	250 (2213)	450 (3983)	900 (7966)
		70:1	10 (89)	40 (354)	80 (708)	180 (1593)	420 (3717)	800 (7081)
		100:1	7 (62)	30 (266)	65 (575)	110 (974)	240 (2124)	450 (3983)
Max Acceleration Output Torque (T _{2a})	Nm (lb-in)	1.5 x Nominal (T _{2n})						
Emergency Output Torque (T _{2not})	Nm (lb-in)	3.5 x Nominal (T _{2n})						
Nominal Input Speed (n _{1n})	RPM	-	4500	4500	4500	4000	3800	2000
Max Input Speed (n _{1max})		-	6000					
Standard Output Backlash (j)	arcmin	1-stage	<4	<4	<4	<4	<4	<4
		2-stage	<6	<6	<6	<6	<6	<6
Reduced Output Backlash (j)	arcmin	1-stage	<3	<2	<2	<2	<2	<2
		2-stage	<5	<4	<4	<4	<4	<4
Allowable Radial Load (F _{rad}) ¹⁾	N (lbf)	-	700 (157)	3,500 (787)	4,500 (1012)	8,000 (1798)	12,000 (2698)	20,000 (4496)
Allowable Axial Load (F _{axial})	N (lbf)	-	600 (135)	1,600 (360)	2,400 (540)	2,400 (540)	6,000 (1349)	10,000 (2248)
Torsional Stiffness (C ₁₂₁)	Nm/arcmin (lb-in/arcmin)	1-stage	2.0 (18)	4.0 (35)	12 (106)	32 (283)	54 (478)	168 (1487)
		2-stage	2.0 (18)	4.0 (35)	12 (106)	32 (283)	54 (478)	168 (1487)
Noise Level (L _{PA})	dB(A)	1-stage	<60	<60	<63	<64	<65	<65
		2-stage	<60	<60	<61	<62	<63	<64
Efficiency at Load	1-stage: 98% 2-stage: 96%							
Service Life	>20,000 hours							

1) Load applied at center of output shaft @ 100 RPM. 2) Excludes size 180