



## ▶ PERFORMANCE: PE SERIES

### GAM can.

If you don't see exactly what you need, let us know. We can modify the PE Series gearboxes to meet your needs. Page 4 provides a list of commonly requested modifications to give you a feel for our capabilities.

The GAM PE series is a great gearbox value for servo, stepper, and other motion control applications. It offers the best quality available for the price point. Based on the design of the popular EPL series, the PE series is a reliable alternative when radial or axial loadings are minimized.

### PE Series offers:

- Metric output (4 sizes)
- NEMA output (4 sizes)
- Wide range of ratios (3:1 to 1000:1)
- Available to purchase online!
- Improved backlash specifications
- Increased service life

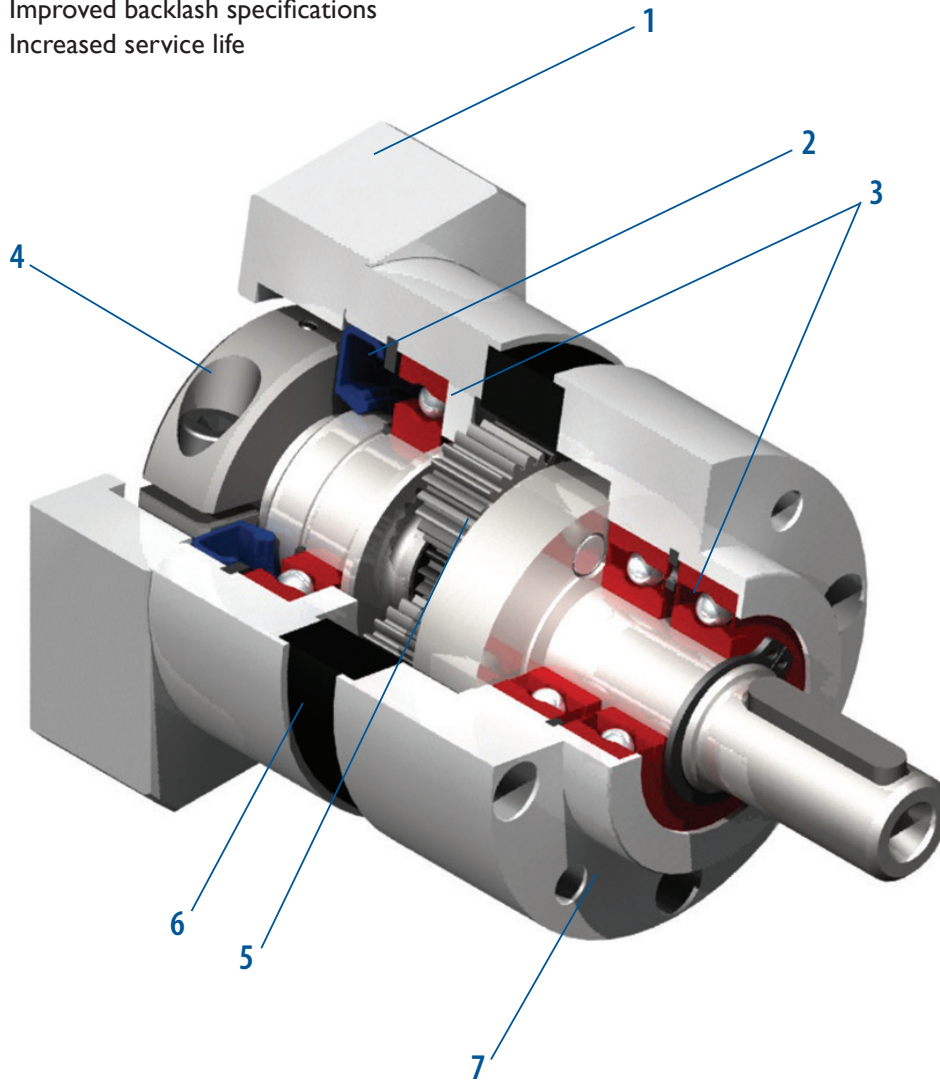

- |   |   |
|---|---|
| 1. Adapter Plate<br>(Customized adapter plates for quick and easy motor mounting) | 4. Input Clamping Element                             |
| 2. Seals<br>(Protective seals to isolate the gearbox)                             | 5. Planet Gears<br>(Precision honed gears)            |
| 3. Ball Bearings<br>(dual ball bearings)  | 6. Ring Gear<br>(Ring gear incorporated into housing) |
|   | 7. Output Face  |

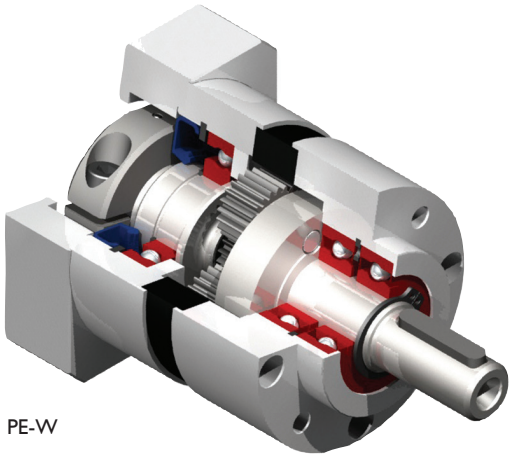

PE-W

**PE-W**

- Metric output face
- Ratios 3:1 to 1000:1
- Frame sizes from 50 mm to 118 mm
- Ready to mount to your motor

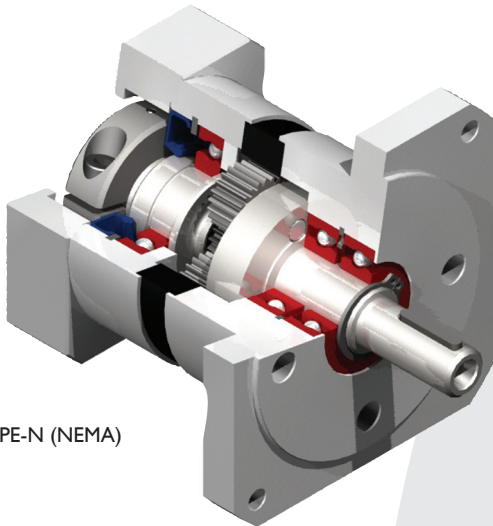

PE-N (NEMA)

**PE-N (NEMA)**

- NEMA output face
- Ratios 3:1 to 1000:1
- Frame sizes from NEMA 17 to 42
- Ready to mount to your motor

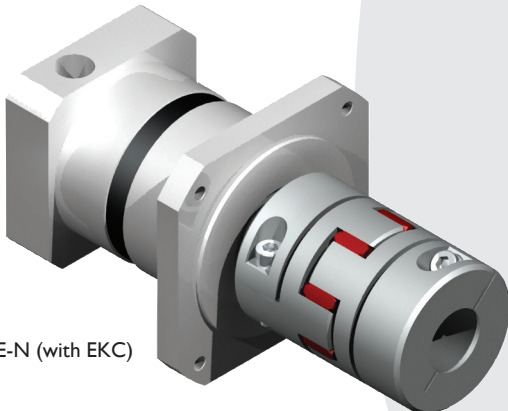

PE-N (with EKC)

**PE-N (shown with GAM's EKC elastomer coupling)**

- Use the PE Series gearbox with the EKC coupling for the most cost-effective solution!



# ▶ PE-W SERIES - (METRIC)

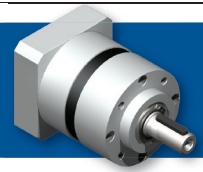

PE-W Series		50	64	84	118	
Stock Ratios		5, 10, 50				
All Ratios Available		1-stage: 3, 4, 5, 7, 10 2-stage: 12, 16, 20, 25, 35, 40, 50, 70, 100 3-stage: 120, 160, 200, 250, 350, 490, 700, 1000				
Nominal Output Torque ( $T_{2n}$ )	Nm (lb-in)	3:1	5 (44)	20 (177)	40 (354)	100 (885)
		4, 5, 7:1	6.5 (58)	26 (230)	54 (478)	120 (1062)
		10, 100, 1000:1	5 (44)	16 (142)	40 (354)	105 (929)
		12:1	14 (124)	36 (319)	80 (708)	170 (1505)
		all other ratios	16 (142)	42 (372)	100 (885)	210 (1859)
Max Acceleration Output Torque ( $T_{2B}$ )	Nm (lb-in)	3:1	10 (89)	36 (319)	70 (620)	180 (1593)
		4, 5, 7:1	13 (115)	44 (389)	100 (885)	200 (1770)
		10, 100, 1000:1	10 (89)	24 (212)	75 (664)	180 (1593)
		12:1	17.5 (155)	45 (398)	100 (885)	215 (1903)
		all other ratios	20 (177)	52 (460)	125 (1106)	255 (2257)
Emergency Output Torque ( $T_{2not}$ )	Nm (lb-in)	3:1	20 (177)	72 (637)	160 (1416)	200 (1770)
		4, 5, 7:1	26 (230)	84 (743)	216 (1912)	480 (4248)
		10, 100, 1000:1	20 (177)	62 (549)	160 (1416)	410 (3629)
		12:1	28 (248)	72 (637)	160 (1416)	400 (3540)
		all other ratios	32 (283)	84 (743)	216 (1912)	480 (4248)
Nominal Speed ( $n_{1n}$ )	RPM	-	3500	3500	3000	2500
Max Speed ( $n_{1max}$ )		-	6000	6000	6000	5000
Standard Output Backlash ( $j$ )	arcmin	3:1 - 10:1	<16	<10	<10	<8
		12:1 - 100:1	<20	<14	<14	<12
		120:1 - 1000:1	-	<18	<18	<16
Allowable Radial Load ( $F_{rad}$ ) <sup>1)</sup>	N (lbs)	-	425 (96)	560 (126)	1300 (293)	2500 (563)
Allowable Axial Load ( $F_{axial}$ )	N (lbs)	-	350 (79)	500 (113)	1000 (225)	1500 (338)
Torsional Stiffness ( $C_{t21}$ )	Nm/arcmin (lb-in/arcmin)	10, 100, 1000	0.60 (5.3)	1.3 (11.5)	3.4 (30.1)	8.3 (73.5)
		7, 70, 700	0.78 (6.9)	1.7 (15)	4.8 (42.5)	13.6 (120.4)
		all other ratios	0.9 (8.0)	2.4 (21.2)	7.1 (62.8)	17.2 (152.2)
Weight (m)	kg (lbs)	1-stage	0.4 (0.9)	1.0 (2.2)	2.3 (5.1)	5.8 (12.8)
		2-stage	0.5 (1.1)	1.3 (2.9)	3.1 (6.8)	7.9 (17.4)
		3-stage	- (-)	1.6 (3.5)	3.9 (8.6)	10.0 (22.1)
Noise Level ( $L_{pA}$ )	dB(A)	-	< 64	< 66	< 68	< 70
Mass Moment of Inertia ( $J_1$ )	kg cm <sup>2</sup> (lb-in <sup>2</sup> ) (lb-in <sup>2</sup> )	3:1	0.06 (0.021)	0.45 (0.154)	1.37 (0.468)	6.54 (2.235)
		4:1, 12:1, 16:1	0.04 (0.014)	0.38 (0.130)	1.14 (0.390)	4.8 (1.640)
		5:1, 20:1, 25:1	0.04 (0.014)	0.36 (0.123)	1.05 (0.359)	4.05 (1.384)
		7:1, 35:1	0.04 (0.014)	0.35 (0.120)	0.97 (0.331)	3.4 (1.162)
		10:1, 40:1 - 100:1	0.04 (0.014)	0.34 (0.116)	0.93 (0.318)	3.1 (1.059)
		120:1 - 1000:1	(0.000)	0.34 (0.116)	0.93 (0.318)	3.12 (1.066)
Efficiency at Load	1-stage: 94% 2-stage: 92% 3-stage: 90%					
Service Life	>20,000					
Lubrication	Mineral Grease EP0					
Protection Rating	IP 64					
Operating Temperature Range	-20°C to 90°C					

1) Load applied at center of output shaft @100 RPM

# PE-W

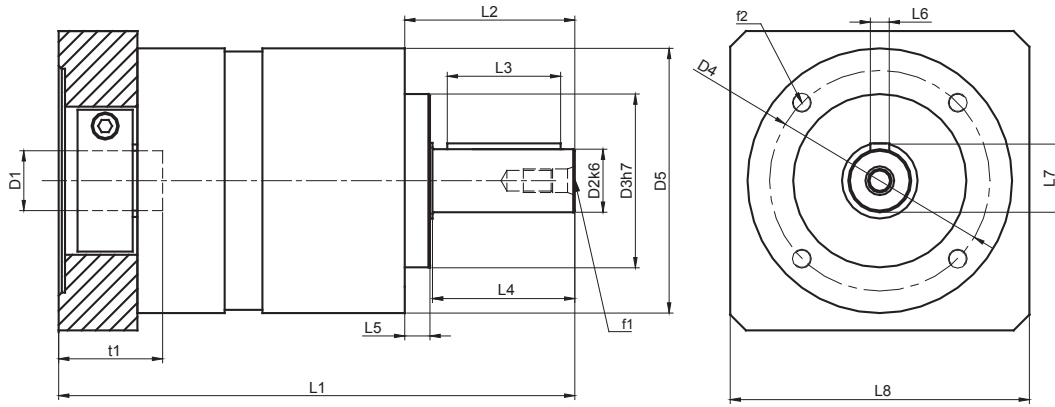

mm (in)		50	64	84	118
D1 <sub>max standard*</sub>	motor shaft diameter	11 (0.433)	14 (0.551)	19 (0.748)	24 (0.945)
D1 <sub>max available*</sub>	motor shaft diameter	14 (0.551)	16 (0.630)	24 (0.945)	32 (1.260)
D2 <sub>k6</sub>	output shaft diameter	12 (0.472)	14 (0.551)	20 (0.787)	25 (0.984)
D3 <sub>h7</sub>	pilot diameter	35 (1.378)	40 (1.575)	55 (2.165)	80 (3.15)
D4	bolt circle	44 (1.732)	52 (2.047)	70 (2.756)	100 (3.937)
D5	housing diameter	50 (1.969)	64 (2.52)	84 (3.307)	118 (4.646)
f1	shaft thread	M4x8	M5x12	M6x16	M10x22
f2	mounting holes	M4x6	M5x12	M6x14	M8x18
L1 1-STAGE**	gearbox total length	93 (3.661)	117 (4.606)	162 (6.378)	199 (7.835)
L1 2-STAGE**		108 (4.252)	139 (5.472)	195 (7.677)	239 (9.409)
L1 3-STAGE**		- (-)	161 (6.339)	228 (8.976)	280 (11.024)
L2	shaft length	24.5 (0.965)	39 (1.535)	54 (2.126)	61 (2.402)
L3	key length	16 (0.63)	25 (0.984)	36 (1.417)	45 (1.772)
L4	usable shaft length	18 (0.709)	30 (1.181)	45 (1.772)	50 (1.969)
L5	pilot height	4 (0.157)	8 (0.315)	8 (0.315)	10 (0.394)
L6	key width	4 (0.157)	5 (0.197)	6 (0.236)	8 (0.315)
L7	key height	13.5 (0.531)	16 (0.63)	22.5 (0.886)	28 (1.102)
L8**	adapter size	50 (1.969)	70 (2.756)	90 (3.543)	120 (4.724)
t1***	allowable shaft length	23 (0.87)	23 (0.906)	30 (1.181)	40 (1.575)

\* for larger motor shaft diameters, please contact GAM \*\* depending on the motor, value can vary \*\*\* long motor shafts can be accommodated, but overall gearbox length will grow  
 \*\*\*\*The PE-W-050 may have a blue ring gear

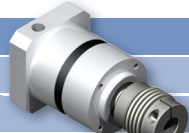
	Recommended Output Coupling (if necessary)			
	metal bellows	KLC-25	KLC-50	KLC-125
elastomer	EKC-25	EKC-35	EKC-80 or 110	EKM-300

## TYPE CODES FOR PE-W SERIES (METRIC)

**Example: PE - W - 084 - 005 G - [115 - A01] - S111**

**Gearbox Series**

PE w/ Metric Output

**Gearbox Style**

W = Output Shaft

**Gearbox Size**

050, 064, 084, 118

**Ratio**

3, 4, 5, 7, 10, 12, 16, 20, 25, 35, 40, 50, 70, 100, 120, 160, 200, 250, 350, 490, 700, 000=1000

**Special Options**

Assigned by GAM

**Motor Mount Kit**

Assigned by GAM

**Options Available for This Product**

G = Key on output shaft per DIN6885

### Tolerances (mm)

Size	k6	h7
Over 6	+0.010	0
Thru 10	+0.001	-0.015
Over 10	+0.012	0
Thru 18	+0.001	-0.018
Over 18	+0.015	0
Thru 30	+0.002	-0.021
Over 30	+0.018	0
Thru 50	+0.002	-0.025
Over 50	+0.020	0
Thru 80	+0.002	-0.030

Sold & Serviced By:

**ELECTROMATE**

Toll Free Phone (877) SERV099

Toll Free Fax (877) SERV099

www.electromate.com

sales@electromate.com



# ▶ PE-N SERIES - (NEMA)

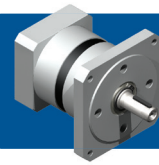

PE-N Series		17	23	34	42	
Stock Ratios		5, 10, 50				
All Ratios Available		1-stage: 3, 4, 5, 7, 10 2-stage: 12, 16, 20, 25, 35, 40, 50, 70, 100 3-stage: 120, 160, 200, 250, 350, 490, 700, 1000				
Nominal Output Torque (T <sub>2n</sub> )	Nm (lb-in)	3:1	5 (44)	5 (44)	20 (177)	40 (354)
		4, 5, 7:1	6.5 (58)	6.5 (58)	26 (230)	54 (478)
		10, 100, 1000:1	5 (44)	5 (44)	16 (142)	40 (354)
		12:1	14 (124)	14 (124)	36 (319)	80 (708)
		all other ratios	16 (142)	16 (142)	42 (372)	100 (885)
Max Accel. Torque (T <sub>2B</sub> )	Nm (lb-in)	3:1	10 (89)	10 (89)	36 (319)	70 (620)
		4, 5, 7:1	13 (115)	13 (115)	44 (389)	100 (885)
		10, 100, 1000:1	10 (89)	10 (89)	24 (212)	75 (664)
		12:1	17.5 (155)	17.5 (155)	45 (398)	100 (885)
		all other ratios	20 (177)	20 (177)	52 (460)	125 (1106)
Emergency Output Torque (T <sub>2not</sub> )	Nm (lb-in)	3:1	20 (177)	20 (177)	72 (637)	160 (1416)
		4, 5, 7:1	26 (230)	26 (230)	84 (743)	216 (1912)
		10, 100, 1000:1	20 (177)	20 (177)	62 (549)	160 (1416)
		12:1	28 (248)	28 (248)	72 (637)	160 (1416)
		all other ratios	32 (283)	32 (283)	84 (743)	216 (1912)
Nominal Speed (n <sub>1n</sub> )	RPM	-	3500	3500	3500	3000
Max Input Speed (n <sub>1max</sub> )		-	6000	6000	6000	6000
Standard Output Backlash (j)	arcmin	3:1 - 10:1	<20	<16	< 10	< 10
		12:1 - 100:1	<24	<20	< 14	< 14
		120:1 - 1000:1	-	-	< 18	< 18
Allowable Radial Load (F <sub>rad</sub> ) <sup>1)</sup>	N (lbs)	-	361 (81)	361 (81)	476 (107)	1105 (249)
Allowable Axial Load (F <sub>axial</sub> )	N (lbs)	-	298 (67)	298 (67)	425 (96)	850 (191)
Torsional Stiffness (C <sub>t21</sub> )	Nm/arcmin (lb-in/arcmin)	10, 100, 1000	0.50 (4.4)	0.60 (5.3)	1.3 (11.5)	3.4 (30.1)
		7, 70, 700	0.65 (5.8)	0.78 (6.9)	1.7 (15)	4.8 (42.5)
		all other ratios	0.8 (7.5)	0.9 (8.0)	2.4 (21.2)	7.1 (62.8)
Weight (m)	kg (lbs)	1-stage	0.45 (1.0)	0.45 (1.0)	1.1 (2.4)	2.4 (5.3)
		2-stage	0.55 (1.2)	0.55 (1.2)	1.4 (3.1)	3.2 (7.1)
		3-stage	- (-)	- (-)	1.7 (3.7)	4.0 (8.8)
Noise Level (L <sub>PA</sub> )	dB(A)	-	<60	<64	< 66	< 68
Mass Moment of Inertia (J <sub>1</sub> )	kg cm <sup>2</sup> (lb-in <sup>2</sup> )	3:1	0.0144 (0.005)	0.06 (0.021)	0.45 (0.154)	1.37 (0.468)
		4:1, 12:1, 16:1	0.0096 (0.003)	0.04 (0.014)	0.38 (0.130)	1.14 (0.390)
		5:1, 20:1, 25:1	0.0096 (0.003)	0.04 (0.014)	0.36 (0.123)	1.05 (0.359)
		7:1, 35:1	0.0152 (0.005)	0.04 (0.014)	0.35 (0.120)	0.97 (0.331)
		10:1, 40:1 - 100:1	0.0078 (0.003)	0.04 (0.014)	0.34 (0.116)	0.93 (0.318)
120:1 - 1000:1	- (-)	- (-)	0.34 (0.116)	0.93 (0.318)		
Efficiency at Load	1-stage: 94% 2-stage: 92% 3-stage: 90%					
Service Life	>20,000					
Lubrication	Mineral Grease EPO					
Protection Rating	IP 64					
Operating Temperature Range	-20°C to 90°C					

1) Load applied at center of output shaft @100 RPM

# PE-N

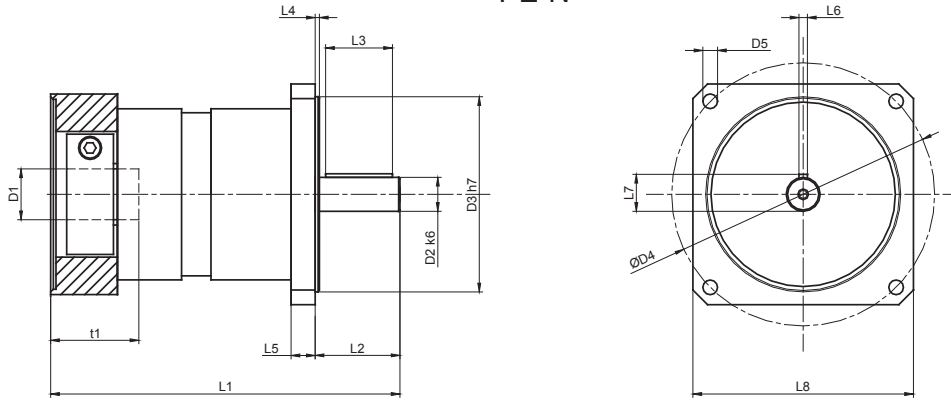

PE-N Series		17		23		34		42	
		mm	(in)	mm	(in)	mm	(in)	mm	(in)
D1 <sup>max standard*</sup>	motor shaft diameter	11	(0.433)	11	(0.433)	14	(0.551)	19	(0.748)
D1 <sup>max available*</sup>	motor shaft diameter	11	(0.433)	14	(0.551)	16	(0.630)	24	(0.945)
D2 <sup>k6</sup>	output shaft diameter	9.525	(0.375)	9.525	(0.375)	12.700	(0.500)	19.05	(0.750)
D3 <sup>h7</sup>	pilot diameter	21.97	(0.865)	38.100	(1.500)	73.025	(2.875)	55.55	(2.187)
D4	bolt circle	43.8	(1.725)	66.7	(2.625)	98.400	(3.875)	125.7	(4.95)
D5	mounting holes	3.25	(0.128)	5	(0.2)	5.5	(0.22)	7.1	(0.28)
L1 1-STAGE**	gearbox total length	108	(4.252)	102	(4.016)	125	(4.921)	162	(6.378)
L1 2-STAGE**		124	(4.882)	122.5	(4.823)	147	(5.787)	194.5	(7.657)
L1 3-STAGE**		-	(-)	-	(-)	169	(6.654)	227	(8.937)
L2	shaft length	25.4	(1.00)	25.4	(1.00)	31.8	(1.25)	31.8	(1.25)
L3	key length	-	(-)	-	(-)	27	(1.06)	29	(1.14)
L4	pilot height	1.6	(0.063)	1.6	(0.06)	1.7	(0.07)	2.4	(0.09)
L5	flange thickness	4.9	(0.193)	5	(0.2)	10	(0.39)	13	(0.51)
L6	key width	-	(-)	-	(-)	3.2	(0.13)	4.8	(0.19)
L7	key height / flat height	9.14	(0.36)	9.14	(0.36)	14.3	(0.56)	18.260	(0.72)
L8	output flange size	40	(1.575)	57.14	(2.25)	82.55	(3.25)	106.68	(4.20)
t1***	allowable motor shaft	25	(0.984)	23	(0.87)	32	(1.26)	40	(1.575)

\* for larger motor shaft diameters, please contact GAM \*\*depending on the motor, value can vary \*\*\* longer motor shafts can be accommodated, but overall gearbox length will grow

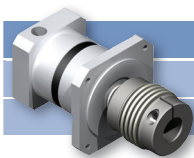

### Recommended Output Coupling (if necessary)

	metal bellows	KLC-25	KLC-25	KLC-50	KLC-125
	elastomer	EKC-25	EKC-25	EKC-80	EKC-110

### TYPE CODES FOR PE-N SERIES (NEMA)

**Example: PE - N23 - 005 G - [115 - A01] - S111**

**Gearbox Series**  
NPE w/ NEMA output

**Gearbox Style**

N17 = NEMA17  
N23 = NEMA23  
N34 = NEMA34  
N42 = NEMA42

**Ratio**

3, 4, 5, 7, 10, 12, 16, 20, 25, 35, 40, 50, 70, 100,  
120, 160, 200, 250, 350, 490, 700, 000=1000

**Special Options**

Assigned by GAM

**Motor Mount Kit**

Assigned by GAM

**Options Available for This Product**

G = Key on output shaft per DIN6885  
flat on NEMA 17 and NEMA 23

Tolerances (mm)		
Size	k6	h7
Over 6	+0.010	0
Thru 10	+0.001	-0.015
Over 10	+0.012	0
Thru 18	+0.001	-0.018
Over 18	+0.015	0
Thru 30	+0.002	-0.021
Over 30	+0.018	0
Thru 50	+0.002	-0.025
Over 50	+0.021	0
Thru 80	+0.002	-0.030