



HIGHEST PERFORMANCE: DYNA SERIES

GAM can.

If you don't see exactly what you need, let us know. We can modify the Dyna Series gearboxes to meet your needs. Page 4 provides a list of commonly requested modifications to give you a feel for our capabilities.

The Dyna Series is our highest performance right-angle gear reducer utilizing sophisticated hypoid gearing. The benefit of hypoid gearing is that it combines the space and configuration advantages of worm gearing with the high efficiencies of bevel gearing. The result is that the Dyna Series is able to achieve ratios up to 15:1 in a single stage and ratios up to 100:1 in 2 stages.

⚠️ **DSX version for the highest performance available!**

The DSX is our flagship right angle hypoid gearbox that has been optimized for the most demanding motion control applications that require high angular accuracy. Featuring hypoid gears that have been ground, the DSX has the smoothest torque transmission and extremely low backlash and noise levels.

Contact GAM for further information on the DSX.

Dyna Series benefits include:

- Ratios up to 15:1 in a single stage – the highest in the market – and 100:1 in just two gear stages
- High efficiencies
- High allowable axial and radial loading
- Ultra low backlash
- Back drivable
- Multiple output shaft configurations and hollow output

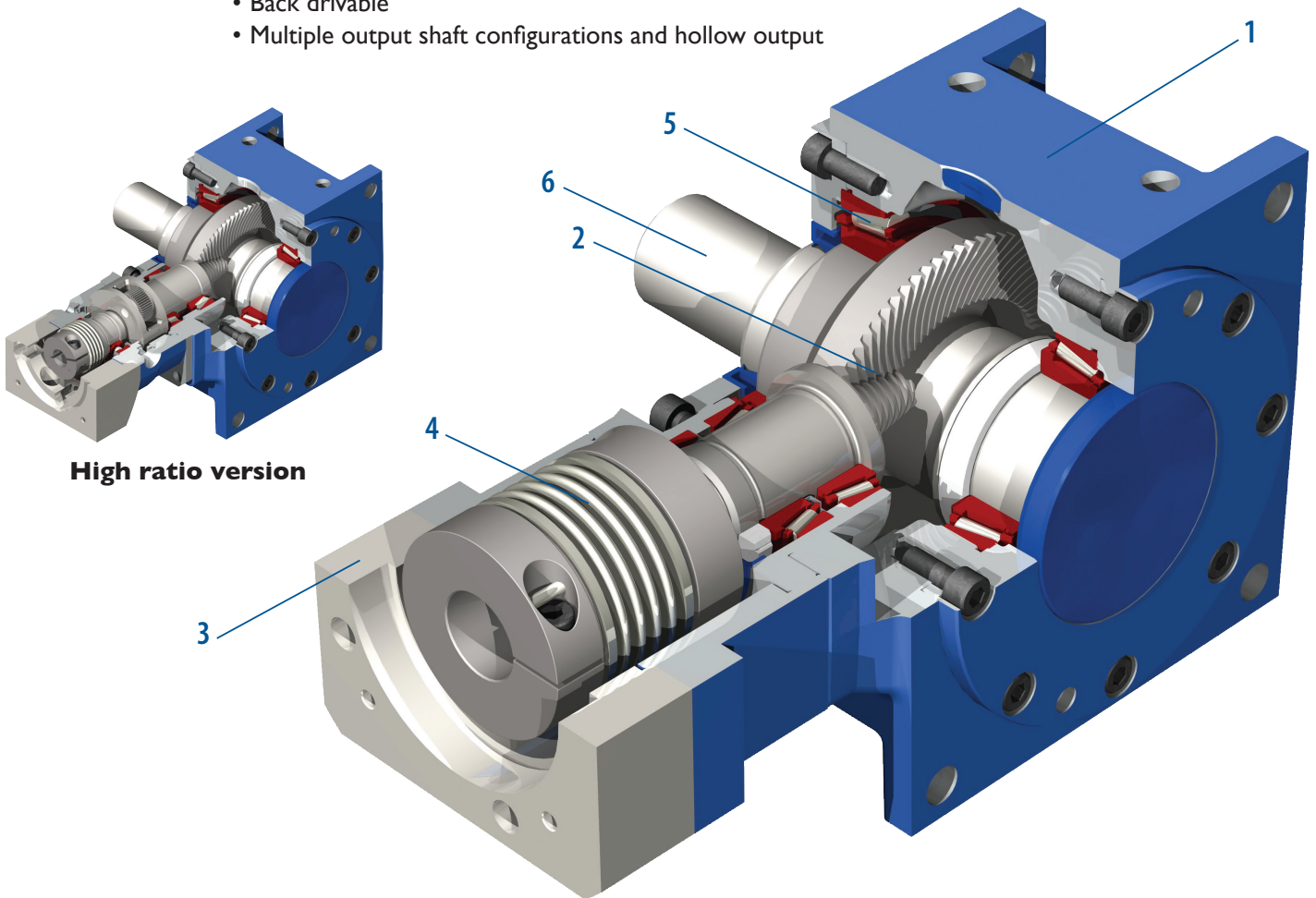

High ratio version

- 1. Aluminum Housing**
(Aluminum housing significantly reduces the weight of the gearbox)
- 2. Hypoid Gearing**
(Optimized gearing allows ratios up to 15:1 in a single stage; 100:1 in two stages. DSX gears are ground for improved performance.)

- 3. Adapter Flange**
(Customized adapter flanges for quick and easy mounting to any motor)
- 4. Coupling**
(Gearbox can be supplied with either a bellows or elastomer coupling)

- 5. Tapered Roller Bearings**
(Roller bearings for high radial and axial loading)
- 6. Output Shaft**
(Gearbox can be supplied with one or two solid shafts or hollow shafts)

Sold & Serviced By:
ELECTROMATE
 Toll Free Phone (877) SERV098
 Toll Free Fax (877) SERV099
www.electromate.com
sales@electromate.com

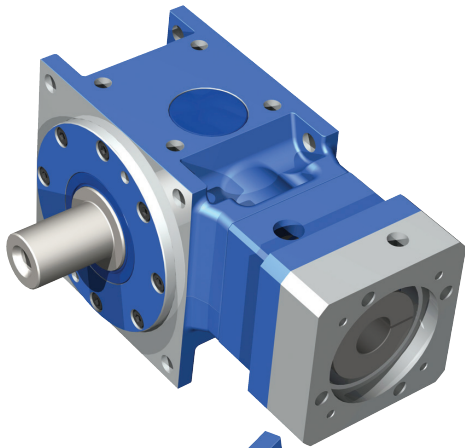

DS-W

- Single output shaft configuration with our high performance bellow coupling input and machined motor flange to mount to any servo motor
- Frame sizes from 55 mm to 190 mm
- ⚠ DSX option available

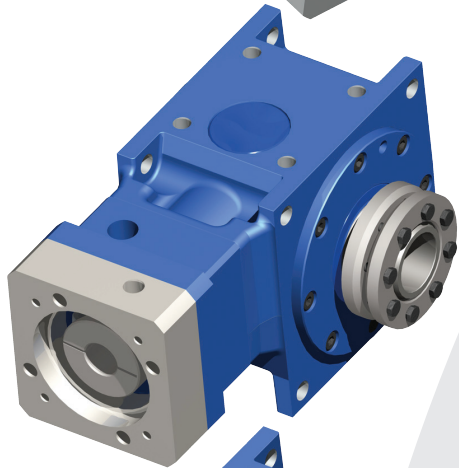

DS-H

- Hollow bore output configuration with our high performance bellow coupling input and machined motor flange to mount to any servo motor
- Zero-backlash shrink disk coupling on the output included with the gearbox
- Frame sizes from 55 mm to 190 mm
- ⚠ DSX option available

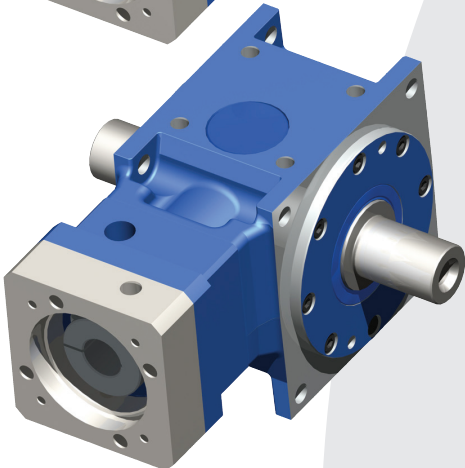

DS-T

- Dual output shaft configuration with our high performance bellow coupling input and machined motor flange to mount to any servo motor
- Frame sizes from 55 mm to 190 mm
- ⚠ DSX option available

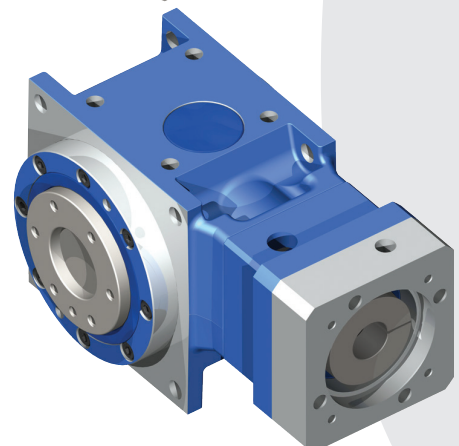

DS-F

- Flange output allows connection of pinion gears, pulleys, rotary index tables, and transmission shafting directly to the output for a more compact and stiffer solution
- Frame sizes from 55 mm to 190 mm
- ⚠ DSX option available



▶ HIGHEST PERFORMANCE: DYNA SERIES

The Advantage of Hypoid Gearing

The GAM Hypoid offers significant advantages over other conventional right-angle gears.

Conventional spiral bevel gearing, meshing in the position shown at the bottom of the drawing, has a purely rolling meshing action that is mechanically very efficient. Its drawback is that it offers the smallest total tooth contact area, so its torque throughput capacity is lower. Single-stage spiral bevel gearing is limited to about a 6:1 reduction ratio. It's easy to get higher ratios with multiple-stage configurations, but the additional gear stage lowers mechanical efficiency, increases backlash, consumes space and weight and reduces reliability.

Conventional worm gearing, meshing in the position shown at the top of the drawing, has a very high total tooth contact area. While it offers high torque throughput and high ratio reduction, worm gearing has the lowest mechanical efficiency, due to the friction generated by its high component of sliding action. Worm gearing is also subject to the kind of wear that demands adjustment in order to maintain accuracy.

Hypoid gearing, meshing at the intermediate position, offers mostly rolling action with a small component of sliding action. It has a greater tooth contact area than bevel gearing, so its load-carrying capability is greater. The GAM Hypoid offers further advantages by going up to a 15:1 gear ratio in a single stage with efficiencies between 93% and 96%, depending upon ratio throughout the speed range. Another important design criterion for precision servo applications is, of course, low backlash in the gear box.

The GAM Hypoid offers two important advantages:

- Single-stage design eliminates backlash from a second set of meshing gears
- Accurate machining and assembly alignment – high-accuracy models offer backlash of ≤ 2 arcminutes.

GAM Hypoid gearing is available in two product ranges, our highest precision Dyna Series, and high precision, Dyna-Lite Series.

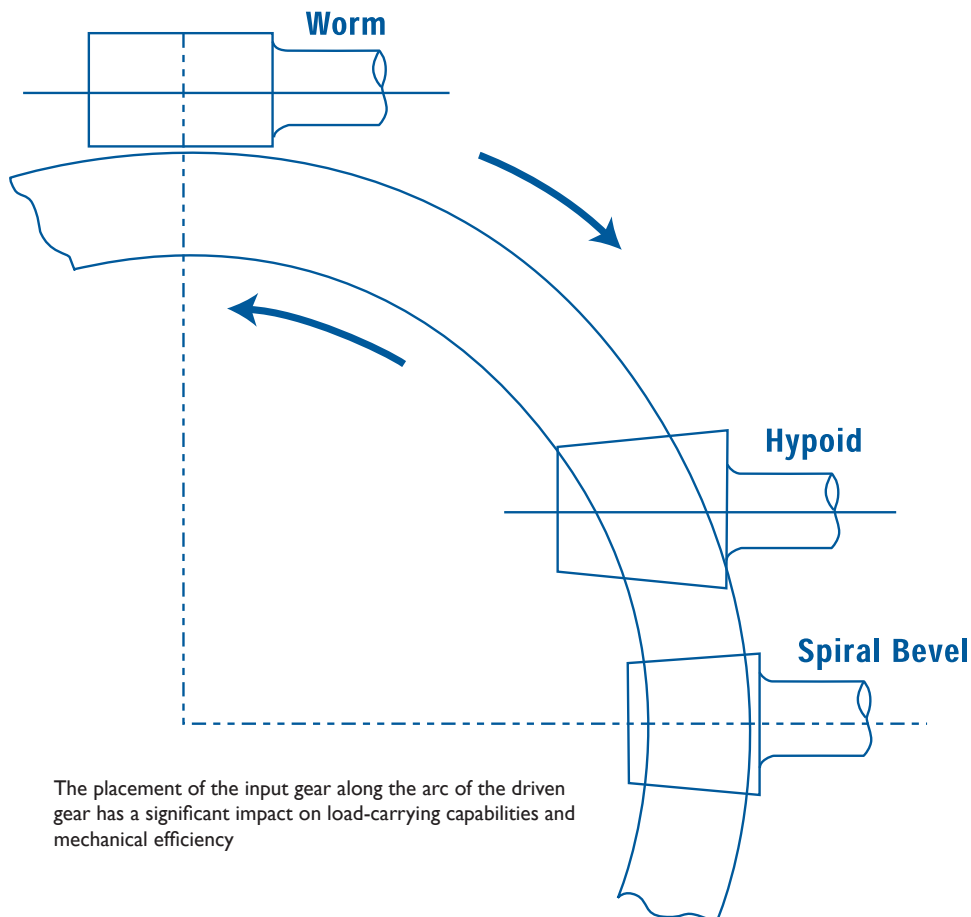

▶ HIGHEST PERFORMANCE: DYNA SERIES

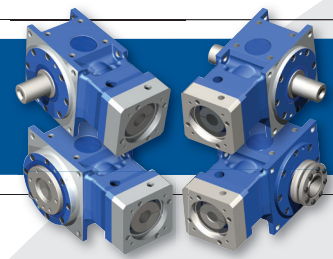

Dyna Series		55	75	90	115	140	190	
Stock Ratios ¹⁾		3, 5, 10, 15, 30, 50, 100			3, 5, 10, 15		N/A	
All Ratios Available		1-stage: 3, 4, 5, 6, 8, 10, 12, 15			2-stage: 25, 30, 40, 50, 70, 100		3-stage: consult GAM	
Nominal Output Torque (T_{2n})	Nm (lb-in)	3:1	35 (310)	70 (620)	140 (1239)	260 (2301)	700 (6196)	1400 (12391)
		4:1	34 (301)	68 (602)	136 (1204)	255 (2257)	690 (6107)	1350 (11949)
		5:1	33 (292)	65 (575)	131 (1159)	250 (2213)	670 (5930)	1280 (11329)
		6:1	32 (283)	61 (540)	124 (1097)	240 (2124)	660 (5841)	1200 (10621)
		8:1	30 (266)	56 (496)	115 (1018)	220 (1947)	640 (5664)	1120 (9913)
		10:1	28 (248)	53 (469)	105 (929)	200 (1770)	560 (4956)	1040 (9205)
		12:1	25 (221)	50 (443)	95 (841)	180 (1593)	480 (4248)	950 (8408)
		15:1	22 (195)	45 (398)	80 (708)	160 (1416)	400 (3540)	800 (7081)
	All 2-Stage Ratios	35 (310)	70 (620)	140 (1239)	260 (2301)	700 (6196)	1400 (12391)	
Max Acceleration Output Torque (T_{2B})	Nm (lb-in)	-	1.5 x Nominal	1.5 x Nominal	1.5 x Nominal	1.5 x Nominal	1.5 x Nominal	
Emergency Output Torque (T_{2not})	Nm (lb-in)	3:1-6:1	70 (620)	140 (1239)	280 (2478)	520 (4602)	1400 (12391)	2800 (24782)
		8:1-10:1	60 (531)	110 (974)	230 (2036)	440 (3894)	1280 (11329)	2240 (19826)
		12:1-15:1	50 (443)	100 (885)	190 (1682)	360 (3186)	960 (8497)	1900 (16816)
		All 2-Stage Ratios	70 (620)	140 (1239)	280 (2478)	520 (4602)	1400 (12391)	2800 (24782)
Nominal Input Speed ⁶⁾ (n_{1n})	RPM	1 Stage	6000	6000	5000	4000	3000	2500
		2 Stage	3000	3000	3200	3200	2800	2500
Max Input Speed ⁶⁾ (n_{1max})	RPM	1 Stage	8000	8000	7000	6000	5000	4500
		2 Stage	6000	6000	6000	6000	6000	4500
Standard Output Backlash (j)	arcmin	1 Stage	<5	<5	<4	<4	<4	<4
		2 Stage	<7	<7	<6	<6	<6	<6
Reduced Output Backlash (j)	arcmin	1 Stage	<3	<3	<2	<2	<2	<2
		2 Stage	<4	<4	<3	<3	<3	<3
Noise Level (L_{pk})	dB	-	<70	<71	<74	<74	<74	
Allowable Radial Load ⁴⁾ (F_{rad})	N (lbs)	-	3500 (787)	3800 (854)	4000 (899)	7500 (1686)	11000 (2473)	15000 (3372)
Allowable Axial Load (F_{axial})	N (lbs)	-	1400 (315)	1520 (342)	1600 (360)	3000 (674)	4400 (989)	6000 (1349)
Maximum Tilting Moment	Nm (lb-in)	-	145 (1283)	173 (1531)	238 (2106)	510 (4513)	990 (8763)	1650 (14604)
Torsional Stiffness (C_{t21}) ⁵⁾	Nm/arcmin (lb-in/arcmin)	1 Stage	2.1 (18.6)	4.2 (37.2)	10.5 (92.9)	23.4 (207.1)	61.8 (547.0)	126 (1115.2)
		2 Stage	2.1 (18.6)	4.2 (37.2)	10.2 (90.3)	22.8 (201.8)	60.1 (531.9)	119.2 (1055.0)
Weight (m)	kg (lbs)	1 Stage	3 (6.6)	6 (13.2)	10 (22.0)	17 (37.5)	39 (86.0)	55 (121.3)
		2 Stage	4 (8.8)	7 (15.4)	11 (24.3)	22 (48.5)	49 (108.0)	65 (143.3)
Mass Moment of Inertia	kg cm ² (lb-in ²)	3:1	0.584 (0.200)	1.32 (0.451)	3.41 (1.165)	8.49 (2.901)	29.7 (10.149)	91.3 (31.199)
		4:1	0.439 (0.150)	0.993 (0.339)	2.46 (0.841)	6.03 (2.061)	20 (6.834)	61.2 (20.913)
		5:1	0.357 (0.122)	0.834 (0.285)	1.98 (0.677)	4.79 (1.637)	14.7 (5.023)	45.1 (15.412)
		6:1	0.258 (0.088)	0.747 (0.255)	1.24 (0.424)	4.04 (1.381)	11.7 (3.998)	34.9 (11.926)
		8:1	0.214 (0.073)	0.654 (0.223)	0.958 (0.327)	3.36 (1.148)	9.08 (3.103)	25.8 (8.816)
		10:1	0.192 (0.066)	0.612 (0.209)	0.842 (0.288)	3.04 (1.039)	7.85 (2.683)	21.8 (7.449)
		12:1	0.181 (0.062)	0.592 (0.202)	0.78 (0.267)	2.87 (0.981)	7.14 (2.440)	19.6 (6.698)
		15:1	0.17 (0.058)	0.568 (0.194)	0.715 (0.244)	2.72 (0.929)	6.55 (2.238)	19.5 (6.664)
		30:1	0.405 (0.138)	0.487 (0.166)	1.309 (0.447)	4.043 (1.382)	7.100 (2.426)	13.944 (4.765)
		40:1	0.367 (0.126)	0.402 (0.137)	1.084 (0.370)	3.477 (1.188)	5.050 (1.726)	7.625 (2.606)
		50:1	0.354 (0.121)	0.373 (0.128)	1.009 (0.345)	3.292 (1.125)	4.388 (1.499)	5.604 (1.915)
		70:1	0.352 (0.120)	0.356 (0.122)	0.978 (0.334)	3.430 (1.172)	4.779 (1.633)	4.918 (1.681)
100:1	0.342 (0.117)	0.346 (0.118)	0.938 (0.321)	3.130 (1.070)	3.879 (1.325)	4.018 (1.373)		
Efficiency at Load		3:1-8:1 > 96%			10:1-15:1 > 93%	30:1-100:1 > 92%		
Service Life		>30,000 hours						
Lubrication		Synthetic Oil: ISO VG 100						
Protection Rating		IP 64						
Operating Temperature Range		-10°C to 90°C						

1) Stock ratios listed are available in Standard AND Reduced Backlash. 2) Nominal torque and speed values listed are for gear tooth ratings. Use thermal limit for continuous operation. 3) DSX Precision ground gearing for quieter and smoother operation, improved accuracy, and repeatability. 4) Load applied at center of output shaft @400 RPM. 5) Stiffness values relative to DSX version only. Stiffness for DS-H,F may vary slightly- contact GAM for values. 6) Higher input speeds may be possible – consult GAM.



▶ DYNA SERIES - DS-W, DS-H, DS-T, DS-F

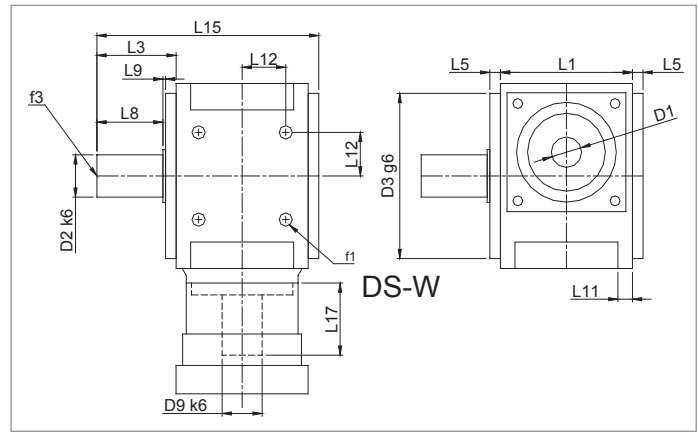
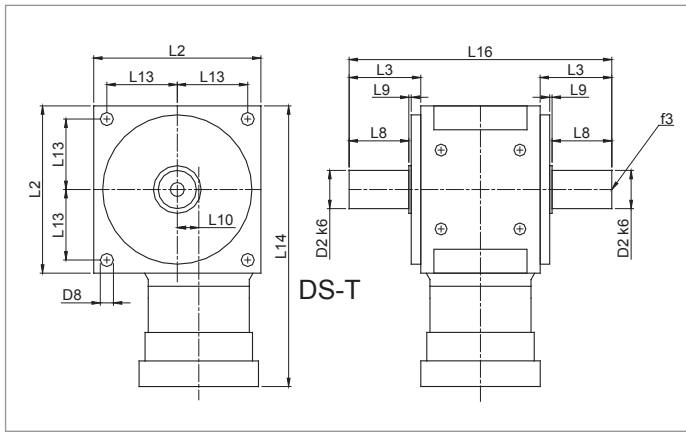
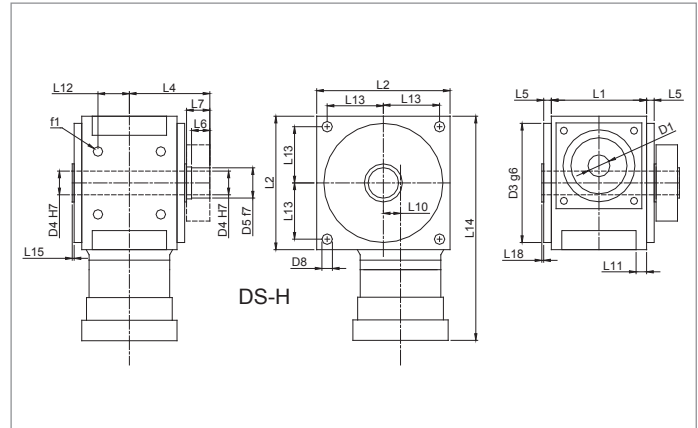
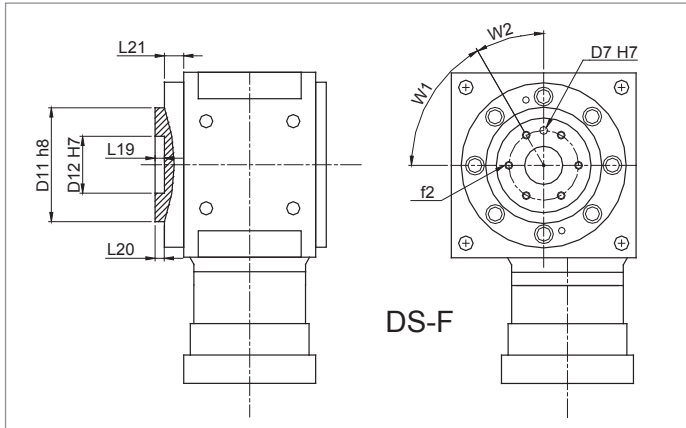

Recommended Output Coupling (if necessary)

metal bellows	KM-60	KM-170	KM-270	KM-400	KM-1300	KSD-2500
elastomer	EKM-60	EKM-150	EKM-300	EKM-500	EKM-1000	-

TYPE CODES FOR DYNA SERIES

Example: DS - W B - 090 - 005 G - [115-201] - S111

Gearbox Series
 DS = Dyna Series
 DSX = Dyna Series Extreme

Gearbox Style
 W = Single output shaft
 T = Dual output shaft
 H = Hollow output shaft
 F = Flange output

Input Type
 B = Bellows coupling input
 E = Elastomer coupling input
 L = Shaft input

Gearbox Size
 055, 075, 090, 115, 130, 140, 160, 190

Ratio
 003, 004, 005, 006, 008, 010,
 012, 015, 030, 040, 050, 070, 100

Special Options
 Assigned by GAM

Motor Mount Kit
 Assigned by GAM

Options Available for This Product

	LOW	OUTPUT
OPTION	BACKLASH	KEYWAY
A=	Y	N
C=	Y	Y
G=	N	Y
H=	N	N

Options C and G N/A for DS-F/H models.

Contact GAM for DSX Drawings

Tolerances (mm)

Size	k6	g6	h8	f7	H7	h6
Over 6	+0.010	-0.005	0	-0.013	+0.015	0
Thru 10	+0.001	-0.014	-0.022	-0.028	0	-0.009
Over 10	+0.012	-0.006	0	-0.016	+0.018	0
Thru 18	+0.001	-0.017	-0.027	-0.034	0	-0.011
Over 18	+0.015	-0.007	0	-0.02	+0.021	0
Thru 30	+0.002	-0.020	-0.033	-0.041	0	-0.013
Over 30	+0.018	-0.009	0	-0.025	+0.025	0
Thru 50	+0.002	-0.025	-0.039	-0.05	0	-0.016
Over 50	+0.021	-0.010	0	-0.03	+0.030	0
Thru 80	+0.002	-0.029	-0.046	-0.06	0	-0.019
Over 80	+0.025	-0.012	0	-0.036	+0.035	0
Thru 120	+0.003	-0.034	-0.054	-0.021	0	-0.022
Over 120	+0.028	-0.014	0	-0.043	+0.043	0
Thru 180	+0.003	-0.039	-0.063	-0.083	0	-0.025

Served by:

 Toll Free Phone (877) SERV098

 Toll Free Fax (877) SERV099

www.electromate.com

sales@electromate.com

Dyna Series		55		75		90		115		140		190	
		mm	(in)	mm	(in)	mm	(in)	mm	(in)	mm	(in)	mm	(in)
D1 _{max 1-stage*}	input shaft diameter	21	(0.827)	28	(1.102)	35	(1.378)	43	(1.693)	55	(2.165)	55	(2.165)
D1 _{max 2-stage*}		14	(0.551)	14	(0.551)	24	(0.945)	24	(0.945)	38	(1.496)	38	(1.496)
D3 g6	pilot diameter	89	(3.504)	105	(4.134)	125	(4.921)	150	(5.906)	195	(7.677)	245	(9.646)
D8	mounting hole diameter	6.6	(0.26)	9	(0.354)	11	(0.433)	14	(0.551)	17.5	(0.689)	17.5	(0.689)
D9 k6	gearbox input shaft dia	14	(0.551)	18	(0.709)	22	(0.866)	28	(1.102)	32	(1.26)	40	(1.575)
f1	mounting hole thread	M6		M8		M10		M12		M16		M16	
L1	housing width	60	(2.362)	80	(3.15)	100	(3.937)	120	(4.724)	146	(5.748)	196	(7.717)
L2	housing size	90	(3.543)	115	(4.528)	140	(5.512)	170	(6.693)	215	(8.465)	260	(10.236)
L5	pilot height	13.5	(0.531)	8.5	(0.335)	8	(0.315)	8	(0.315)	10	(0.394)	10	(0.394)
L10	hypoid offset	9	(0.354)	14	(0.551)	18	(0.709)	23	(0.906)	32	(1.26)	42	(1.654)
L11	flange thickness	8	(0.315)	10	(0.394)	11	(0.433)	13	(0.512)	15	(0.591)	17	(0.669)
L12	hole location	22	(0.866)	27	(1.063)	33	(1.299)	40	(1.575)	52	(2.047)	70	(2.756)
L13	hole location	39	(1.535)	49	(1.929)	59	(2.323)	72	(2.835)	91	(3.583)	112	(4.409)
L14 1-stage**	input length	181	(7.126)	219	(8.622)	250.5	(9.862)	286.5	(11.28)	363.5	(14.311)	439	(17.283)
L14 2-stage**		229.5	(9.035)	262	(10.315)	247.5	(9.744)	280	(11.024)	372	(14.646)	591	(23.268)
L17	input shaft length	20	(0.787)	26	(1.024)	43	(1.693)	48	(1.89)	55	(2.165)	62	(2.441)

* for larger shaft diameters consult GAM ** depending on motor, length may vary

DS-F & DS-H		55		75		90		115		140		190	
		mm	(in)	mm	(in)	mm	(in)	mm	(in)	mm	(in)	mm	(in)
D4 H7**	hollow bore	20	(0.787)	25	(0.984)	30	(1.181)	40	(1.575)	55	(2.165)	70	(2.756)
D5 f7	hollow outer diameter	24	(0.945)	30	(1.181)	36	(1.417)	50	(1.969)	68	(2.677)	80	(3.15)
D6	flange bolt circle	40	(1.575)	50	(1.969)	63	(2.48)	80	(3.15)	100	(3.937)	125	(4.921)
D7 H7	locating hole diameter	6	(0.236)	6	(0.236)	6	(0.236)	8	(0.315)	8	(0.315)	10	(0.394)
D11 h8	flange pilot (OD)	50	(1.969)	63	(2.48)	80	(3.15)	100	(3.937)	125	(4.921)	160	(6.299)
D12 H7	flange pilot (ID)	25	(0.984)	31.5	(1.24)	40	(1.575)	50	(1.969)	63	(2.48)	80	(3.15)
f2	flange tapped holes	7 x M6x9		7 x M6x9		7 x M6x9		11 x M8x12		11 x M8x12		11 x M10x15	
L4	hollow hub length	73	(2.874)	81	(3.189)	95	(3.74)	109	(4.291)	129	(5.079)	161	(6.339)
L6	hub length	20	(0.787)	22	(0.866)	26	(1.024)	29	(1.142)	32	(1.26)	34	(1.339)
L7	shoulder + hub length	23	(0.906)	25	(0.984)	29	(1.142)	33	(1.299)	37	(1.457)	40	(1.575)
L18	shoulder height	1.5	(0.059)	1.5	(0.059)	2	(0.079)	2	(0.079)	2	(0.079)	2	(0.079)
L19	inner flange pilot depth	6.5	(0.256)	6.5	(0.256)	6.5	(0.256)	8.5	(0.335)	8.5	(0.335)	10.5	(0.413)
L20	outer flange pilot height	6.5	(0.256)	6.5	(0.256)	6.5	(0.256)	8.5	(0.335)	8.5	(0.335)	8.5	(0.335)
L21	pilot height	20	(0.787)	15.5	(0.61)	17	(0.669)	20	(0.787)	17.5	(0.689)	22.5	(0.886)
W1	hole angle 1	45°		45°		45°		30°		30°		30°	
W2	hole angle 2	45°		45°		45°		30°		30°		30°	

* for larger shaft diameters, consult GAM ** mating shaft should have h6 tolerance *** depending on motor, length may vary

DS-W & DS-T		55		75		90		115		140		190	
		mm	(in)	mm	(in)	mm	(in)	mm	(in)	mm	(in)	mm	(in)
D2 k6	output shaft diameter	20	(0.787)	24	(0.945)	32	(1.26)	40	(1.575)	55	(2.165)	70	(2.756)
f3	shaft thread per DIN332/1	M6x16		M8x19		M12x28		M16x36		M20x42		M20x42	
L3	output shaft length	50	(1.969)	50	(1.969)	60	(2.362)	70	(2.756)	102	(4.016)	122	(4.803)
L8	usable shaft length	35	(1.378)	40	(1.575)	50	(1.969)	60	(2.362)	90	(3.543)	110	(4.331)
L9	shoulder height	1.5	(0.059)	1.5	(0.059)	2	(0.079)	2	(0.079)	2	(0.079)	2	(0.079)
L15	gearbox width	123.5	(4.862)	138.5	(5.453)	168	(6.614)	198	(7.795)	258	(10.157)	328	(12.913)
L16	gearbox width	160	(6.299)	180	(7.087)	220	(8.661)	260	(10.236)	350	(13.78)	440	(17.323)

* for larger shaft diameters consult GAM ** depending on motor, length may vary