

Sold & Serviced By:
ELECTROMATE
 Toll Free Phone (877) SERV098
 Toll Free Fax (877) SERV099
 www.electromate.com
 sales@electromate.com



Mercury™ 1000 Analog Output Encoder Systems

For Customer Interpolation- Resolution to 0.078µm

Reflective Linear and Rotary Encoders

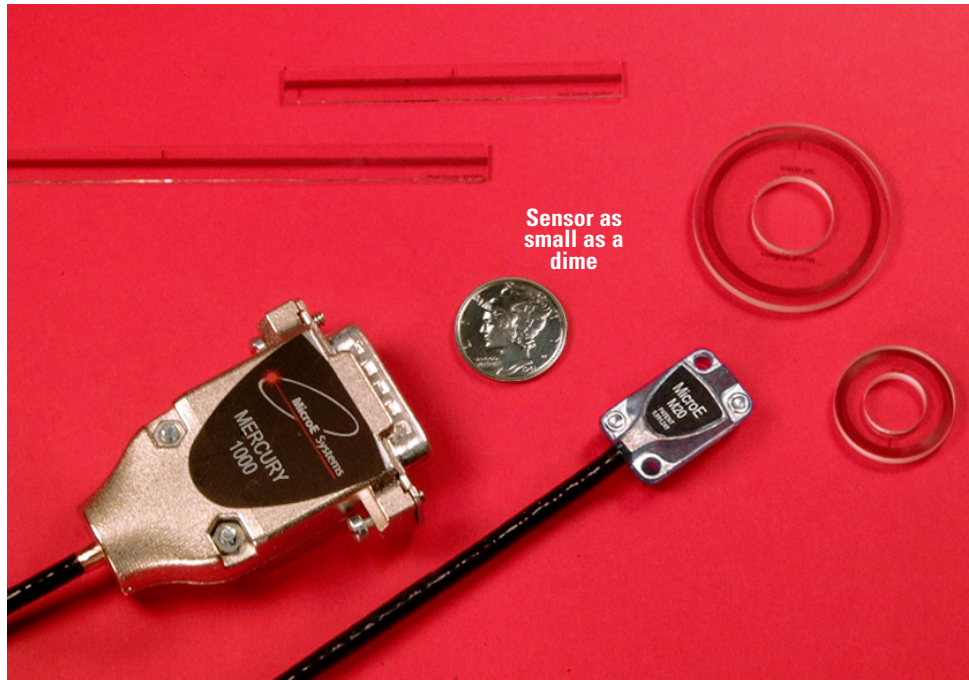

Resolution
 Determined by Customer Electronics
 Linear: 20µm to 0.078µm
 Rotary: 2,500 to 4.2M CPR

Accuracy
 Linear: ± 1µm available
 ± 3µm to ± 5µm standard
 Rotary: Up to ± 2.1 arc-sec

Output
 Analog Sine/Cosine and
 Digital Index Window

The Mercury 1000 encoder system includes the sensor, double shielded cable, connector, and either a linear or rotary glass scale. Mercury's space-saving, integrated configuration gives OEM system designers a breakthrough in performance.

Imagine what you can do with this!

Reduce the cost and size of your system, and increase its performance all at once. MicroE Systems' Mercury 1000 kit encoders are smaller, higher performance, faster to install, and easier to use than any other encoder. Advanced features include SmartPrecision™ automatic offset and gain adjustments during set up to optimize accuracy. No manual adjustments are needed. The tiny sensor fits into very tight spaces, has broad alignment tolerances for fast and easy setup and works in both linear and rotary applications. The entire Mercury 1000 encoder system is EMI shielded for use in the toughest environments. With standard analog sine/cosine output, use your interpolation electronics to achieve the resolution required by your application.

Standard features

- Small sensor with ultra-low Z height; flush screw mounting
- Sensor is 8.4mm (H) x 12.7mm (W) x 20.6mm (L) and weighs 1.6g
- SmartPrecision automatic offset and gain set up
- Analog Sine/Cosine output and Index window
- Fundamental resolution: Linear 20µm; Rotary 2,500 - 16,384 CPR
 Interpolated resolution determined by customer electronics:
 Linear: 20µm - 0.078µm; rotary: 2,500 to 4.2M CPR
- Entire system is EMI shielded
- Bi-directional index signal
- Index mark at the center or end of the glass scale (linear)
- Alignment Tool enables fast set up (Required, see pg 2)

Table of Contents

- System & Sensor** pg 4
- Scales** pg 5-6
- Ordering Information** pg 6

Required accessories

- SmartPrecision Alignment Tool



Optional features

- Glass scale length or diameter:
 Linear lengths from 5mm to 2m
 Rotary diameters from 12mm to 108mm



- Cable length of 0.5m, 1m, 2m or custom
- SmartPrecision Software for set up



System Configurations

Standard and Optional Equipment



Encoder Sensor
 Same for linear and rotary scales.

Controller Interface Cable
 15 pin standard D-sub connector with SmartPrecision™ automatic gain and offset adjustments.

SmartPrecision™ Alignment Tool - SSAT 1000

Required for set up, the built-in LED indicators make alignment fast and easy, eliminating the need for an oscilloscope. In addition, The Alignment Tool automatically optimizes the M1000's gain and offset for increased accuracy with the push of a button.

The RS232 Interface Adapter provides power to the encoder and connections to a PC. This is included with the Alignment Tool.

M1000 Encoder System Standard Equipment

Optional Software

SmartPrecision™ Software



Optional software lets you view signal strength, Lissajous plots, position data and diagnostics.

Broader Alignment Tolerances, Increased Standoff Clearance, Smallest Sensor and More

Why Mercury Encoders Make It Easier To Design High Performance Into Your Equipment

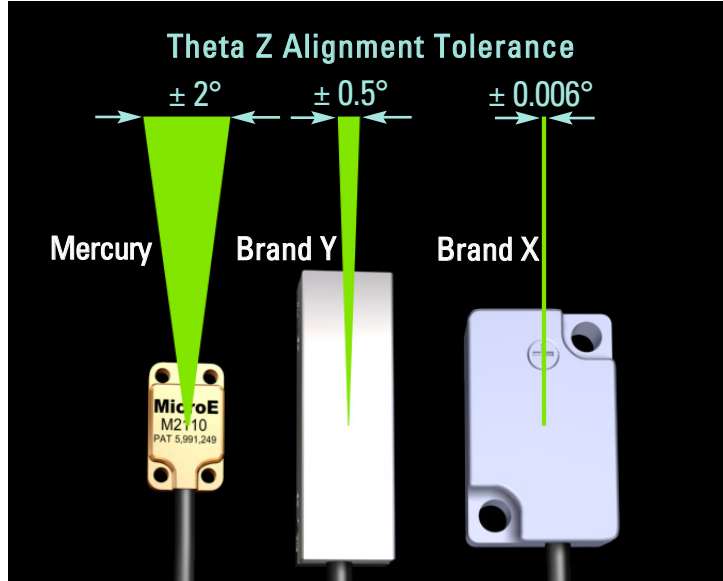

Eliminate the Frustration of Touchy Encoder Alignment

Mercury Solves this Problem for Good

Fussy alignment is no longer a concern. With Mercury's patented PurePrecision™ optics, advanced SmartPrecision™ electronics and LED alignment indicators, you can push the sensor against your reference surface, tighten the screws and you're finished. Try that with brand X or Y.

This performance is possible thanks to relaxed alignment tolerances, particularly in the theta Z axis. Mercury offers a $\pm 2^\circ$ sweet spot— that's a 300% improvement over the best competitive encoder. And that will result in dramatic savings in manufacturing costs.

No other commercially available encoder is easier to align, easier to use, or easier to integrate into your designs.

Alignment Tolerance Comparison**

	Mercury*	Brand X	Brand Y	Mercury vs. Best Competitor
Z Standoff	$\pm 0.15\text{mm}$	$\pm 0.1\text{mm}$	$\pm 0.1\text{mm}$	Mercury is 50% better
Y	$\pm 0.20\text{mm}$ for linear $\pm 0.10\text{mm}$ for rotary $\geq 19\text{mm}$ dia.	$\pm 0.1\text{mm}$	unspecified	Mercury is 100% better
theta X	$\pm 1.0^\circ$	unspecified	$\pm 1.0^\circ$	
theta Y	$\pm 2.0^\circ$	$\pm 0.1^\circ$	$\pm 1.0^\circ$	Mercury is 100% better
theta Z	$\pm 2.0^\circ$	$\pm 0.006^\circ$	$\pm 0.5^\circ$	Mercury is 300% better

*Measured at a constant temperature for one axis at a time with all other axes at their ideal positions.

**Based on published specifications

Mercury Can Reduce System Size and Cost

Mercury's sensor height is 44% shorter than competitive encoders, making it easy to fit into your design. This reduction can also cut total system weight and cost by allowing the use of smaller motors and stages. Safe system operation is also enhanced thanks to Mercury's generous standoff clearance— 200% greater than other encoders. And its standoff tolerance is 50% greater than the best alternative.

This significantly relaxes mechanical system tolerances, while reducing system costs.

Mechanical Dimension Comparison**

	Mercury	Brand X	Brand Y	Mercury vs. Best Competitor
Sensor Z height	8.4mm	23mm	15mm	44% better
Standoff clearance	2.4mm	0.5mm	0.8mm	200% better
Standoff tolerance	$\pm 0.15\text{mm}$	$\pm 0.1\text{mm}$	$\pm 0.1\text{mm}$	50% better
System height	11.7mm	28.5mm	15.8mm	26% better

**Based on published specifications

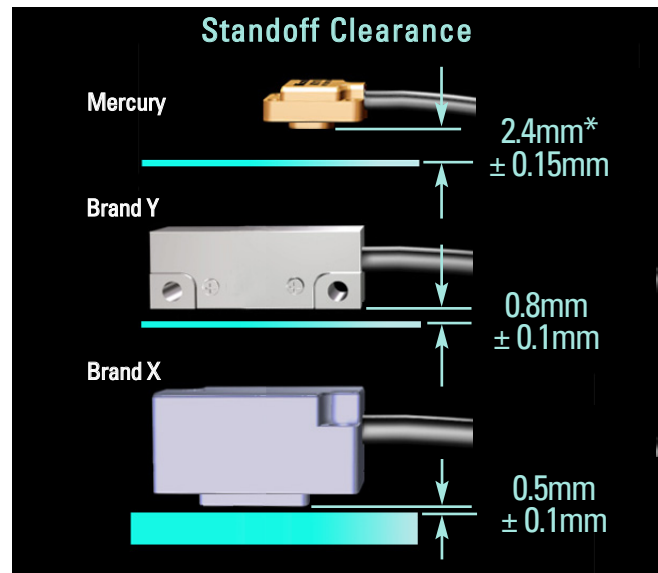

* Dimensions shown illustrate encoder system standoff clearance; see Mercury Encoder Interface Drawings for correct design reference surfaces.

System Specifications

System

Grating Period	20µm
Signal Period	20µm
System Resolution	Fundamental resolution: Linear 20µm; Rotary 2500 - 16,384 CPR Interpolated resolution determined by customer electronics: Linear: 20µm - 0.078µm; rotary: 2,500 to 4.2M CPR

Linear Accuracy* Better than ±1µm available; contact MicroE
 Better than ±3µm up to 130mm, ±5µm from 155mm to 1m,
 ±5µm per meter from 1m to 2m

*Maximum peak to peak error over the specified movement when compared to a NIST-traceable laser interferometer standard, used at room temperature and with MicroE interpolation electronics.

Rotary Accuracy*	Scale O.D.	Microradians	Arc-Seconds
	12.00mm	±100	±21
	19.05mm	±63	±13
	31.75mm	±38	±7.8
	57.15mm	±19	±3.9
	107.95mm	±10	±2.1

*Based on ideal scale mounting concentricity

Sensor Size

W:	12.70mm	0.500"
L:	20.57mm	0.810"
H:	8.38mm	0.330"

Operating and Electrical Specifications

Power Supply	5VDC ±5% @ 60mA
Temperature	
Operating:	0 to 70°C
Storage:	-20 to 70°C
Humidity:	10 - 90% RH non-condensing
EMI:	Entire system is EMI/RFI protected
Shock:	1500G 0.5ms half sine (Sensor)
Sensor Weight:	2.7g (Sensor without cable)
Cable:	Double Shield. Diameter: 3.6mm (0.142") Flex Life: 20 x 10 ⁶ cycles @ 20mm bending radius

Maximum Speed

	Scale Length/Diameter	Maximum Speed*
Linear	All Lengths	7200mm/s
Rotary	0.75"	8640 RPM
	1.25"	5272 RPM
	2.25"	2637 RPM
	4.25"	1318 RPM

*Assumes customer electronics have adequate bandwidth

Mechanical Information - Sensor and Connector

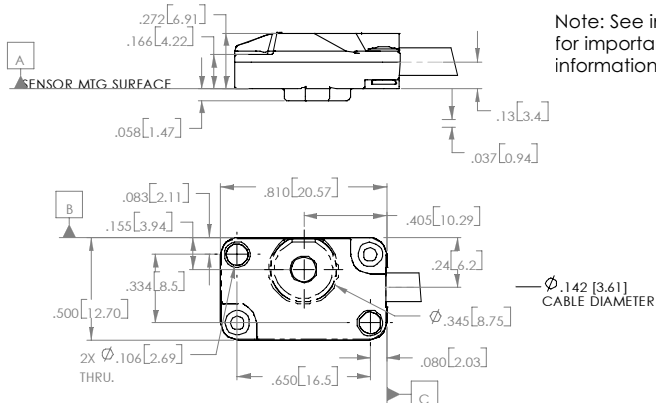

Analog Output Pins 7,8,14 and 15

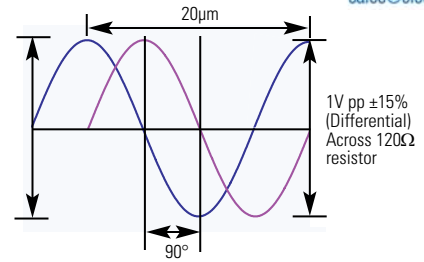

Mercury 1000 Outputs

15-pin Standard Male D-sub connector

PIN	FUNCTION
1	Index Window-
2	Index Window+
3	Reserved - do not connect
4	Reserved - do not connect
5	Reserved - do not connect
6	Reserved - do not connect
7	Cosine+
8	Sine+
9	Reserved - do not connect
10	Reserved - do not connect
11	Reserved - do not connect
12	+5VDC
13	Ground
14	Cosine-
15	Sine -

Index Window Pin 2

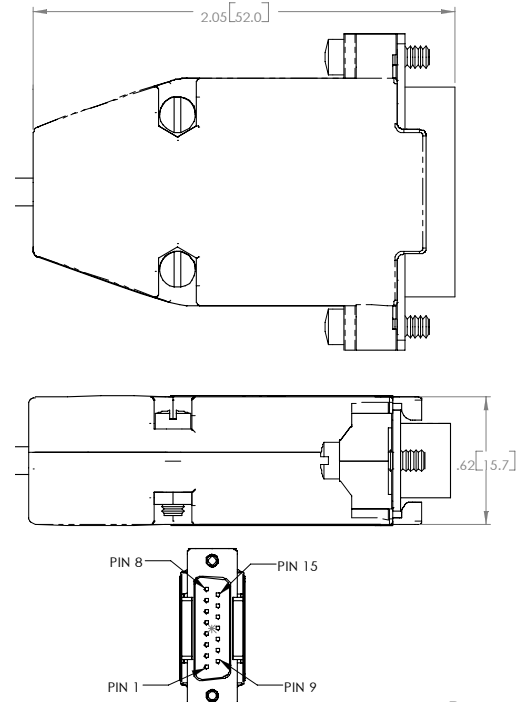
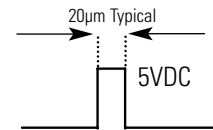

Scale Specifications

Standard and Customized Scales

MicroE Systems offers a wide array of chrome on glass scales for the highest accuracy and best thermal stability. Easy to install, standard linear and rotary scales meet most application requirements. Customized linear, rotary, and rotary segment scales are available where needed. All scales include an optical index. Mercury's glass scales save time by eliminating motion system calibrations or linearity corrections required by other encoders, and provide better thermal stability than metal tape scales.

Options include:

- *Standard linear*: 18mm - 2m
- *Standard rotary*: 12mm - 107.95mm diameter, with or without hubs
- *Custom linear**: special lengths, widths, thickness, index mark locations and special low CTE materials
- *Custom rotary**: special ID's, OD's (up to 304.8mm), index mark outside the main track and special low CTE materials
- *Mounting of hubs for rotary scales*: MicroE Systems can mount and align standard, custom, or customer-supplied hubs
- *Rotary segments**: any angle range; wide range of radius values

*Custom scales or rotary segments are available in OEM quantities. Contact your local MicroE Systems sales office.

Standard Short Linear Scales

130mm and Shorter

Key: inches[mm]

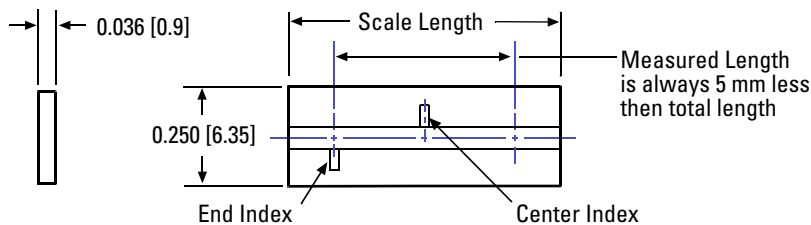

Specifications

Accuracy	±3µm standard ±1µm available
Material	Soda lime glass
Typical CTE	8ppm/°C
Index	Center or End

Model	L18	L30	L55	L80	L105	L130
Scale Length	0.709 [18]	1.181 [30]	2.165 [55]	3.150 [80]	4.134 [105]	5.118 [130]
Measured Length	0.512 [13]	0.984 [25]	1.969 [50]	2.953 [75]	3.937 [100]	4.921 [125]

Custom scales available

Standard Long Linear Scales

155mm and Longer

Key: inches[mm]

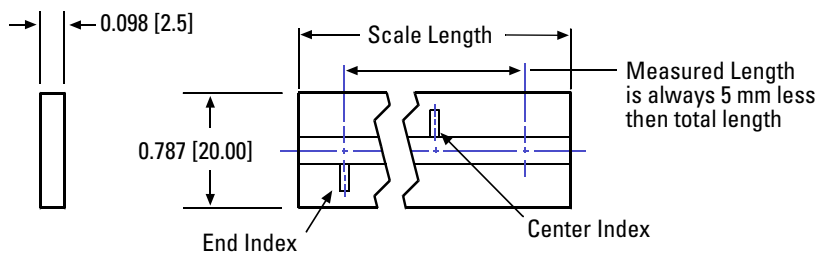

Specifications

Accuracy	±5 µm <1m ±5 µm/m >1m
Material	Soda lime glass
Typical CTE	8ppm/°C
Index	Center or End

Model	L155	L225	L325	L425	L525	L1025	L2025
Scale length	6.102 [155]	8.858 [225]	12.795 [325]	16.732 [425]	20.669 [525]	40.354 [1025]	79.724 [2025]
Measured length	5.906 [150]	8.661 [220]	12.598 [320]	16.535 [420]	20.472 [520]	40.157 [1020]	79.528 [2020]

Custom scales available

Standard Rotary Scales

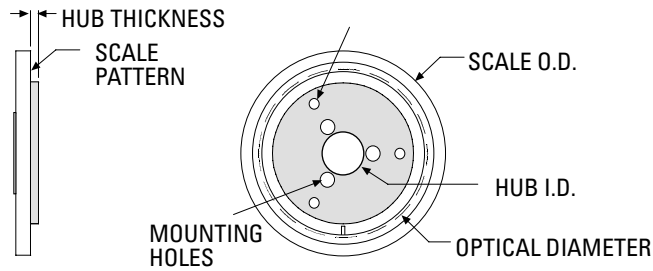

Specifications

Material	Soda lime glass
Typical CTE	8ppm/°C

Key: inches[mm]

Model No.	Scale Outer Diameter	Scale Inner Diameter	Optical Diameter	Hub Inner Diameter +0.0005/-0.0000	Hub Thickness	Fundamental CPR
R1206	0.472 [12.00]	0.250 [6.35]	0.413 [10.50]	0.1253 [3.18]	0.040 [1.02]	1650
R1910	0.750 [19.05]	0.375 [9.52]	0.627 [15.92]	0.1253 [3.183]	0.040 [1.02]	2500
R3213	1.250 [31.75]	0.500 [12.70]	1.027 [26.08]	0.2503 [6.358]	0.050 [1.27]	4096
R5725	2.250 [57.15]	1.000 [25.40]	2.053 [52.15]	0.5003 [12.708]	0.060 [1.52]	8192
R10851	4.250 [107.95]	2.000 [50.80]	4.106 [104.30]	1.0003 [25.408]	0.080 [2.03]	16384

Custom scales available

How to Order Mercury 1000 Encoder Systems

To specify your Mercury encoder with the desired scale, cable length and software, consult the chart below to create the correct part number for your order. Call MicroE Systems' Rapid Customer Response team for more information [508] 903-5000.

Example (Linear Encoder): M1000-M05-L55-C1

Example (Rotary Encoder): M1000-M10-R1910-HA

<u>M1000</u>	-	<u>Cable Length</u>	-	<u>Scale Model</u>	-	<u>Scale Mounting</u>
		M05 = 0.5 m		Lxxx or Rxxxx		For linear scales:
		M10 = 1.0 m				T = Tape mounting
		M20 = 2.0 m				C1 = 3 scale clamps*
						C2 = 10 scale clamps**
						Hubs for Rotary Scales:
						NH = Without Hub
						HE = for R1206
						HA = for R1910
						HB = for R3213
						HC = for R5725
						HD = for R10851

* 3 clamps for linear scales up to 130mm
 ** 10 clamps for linear scales 155mm or longer

How to Order SmartPrecision Alignment

Required for M1000 setup

Example: Alignment Tool for Mercury 1000 encoder, 120 VAC = SSAT1000-120

<u>SSAT1000</u>	-	<u>Voltage</u>
		120 = 120 VAC, 60Hz US Std. 2-prong plug
		220 = 220 VAC, 50Hz European Std. 2-prong plug

How to Order SmartPrecision Software

Optional for SSAT1000 Alignment Tool

SmartPrecision Software

SSWA-AT = SmartPrecision software on CD

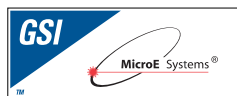

All Specifications are subject to change. All data is accurate to the best of our knowledge. MicroE Systems is not responsible for errors.