



**Applied
Motion
Products**

2008 Product Catalog



**Step Motors & Drives
Servo Motors & Drives**

Sold & Serviced By:

 **ELECTROMATE**

Toll Free Phone (877) SERV098

Toll Free Fax (877) SERV099

www.electromate.com

sales@electromate.com

WELCOME

Welcome to the 2008 Applied Motion short form catalog. This year we celebrate 30 years in Motion Control , so we are looking forward to making it our best year ever.

New Products – there are new products this year. Check out the ST drives on page 29. There’s more in store for 2008. Keep an eye on our website for new developments.

New Format – a new layout for 2008, each product data box has a “quicklink” to take you directly to the in-depth information on our website, which now includes more drawings, 3D models and Flash based training.

Don’t forget, we are always waiting to hear from you on any new projects or applications you have.

The Applied Motion Team



ISO9001:2000 CERTIFIED

BSI British Standards is the UK’s national standards organization that produces standards and information products that promote and share best practice.



QUICKLINK FEATURE:

Jump to specific product web pages easily by typing a short code word. Each product’s web page can be accessed by typing the URL below followed by the product’s “quick link code”:

www.applied-motion.com/7080

“QuickLinks” are located next to each product for your convenience.

QUICKLINK: 7080

FEATURES

- ▶ Step & Direction
5-12v (24 possible)
- ▶ Microstepping
200 to 50800 steps / rev
- ▶ Idle Current Reduction
50% or 100%
- ▶ Screw Terminals
- ▶ Dip Switch Setup
- ▶ Enable Input

Sold & Serviced By:

 **ELECTROMATE**

Toll Free Phone (877) SERV098

Toll Free Fax (877) SERV099

www.electromate.com

sales@electromate.com



About Us

➤ About Applied Motion Products	5
➤ Glossary	105

Software

➤ Si Programmer™	Point and Click Software	8
➤ Q Programmer™	Powerful text based Programming	9
➤ STAC6 Configurator™	Setup and Configuration of the STAC6	10
➤ ST Configurator™	Setup and Configuration of the ST Drives	11
➤ Quick Tuner™	Setup and Configuration of the Servo Drives	12
➤ SiNet™ Hub Programmer	Multi-axis Point and Click Programming	13
➤ SCL Setup Utility	Terminal for testing SCL Serial Commands	14

DC Input Step Drives

➤ 2035	Low Cost Step Motor Drive	16
➤ 2035-O	Low Cost Step Motor Drive with Oscillator	16
➤ 2035-XD	Dual Axis Microstepping Step Motor Drive	18
➤ 3535	Low Cost Step Motor Drive	18
➤ 3535-O	Step Motor Drive with Oscillator	18
➤ 3540M	Microstepping / Step & Direction Input Drive	18
➤ 3540MO	Step Motor Drive with Digital Oscillator	19
➤ 7080	High Powered Step Drive	19
➤ 1240i	Programmable Step Motor Drive	24
➤ 3540i	Programmable Step Motor Drive	24
➤ 7080i	Programmable Step Motor Drive	25
➤ ST 5/10-S	High Performance Step Motor Drive	32
➤ ST 5/10-O	High Performance Programmable Step Motor Drive	32
➤ ST 5/10-Si	High Performance Programmable Step Motor Drive	33

STAC6 Series - HIGH PERFORMANCE AC INPUT STEP DRIVES

➤ STAC6 Drives	AC Input Packaged Step Drives	38/39
➤ Detailed Specifications		39
➤ STAC6 Motors		40/41

Sold & Serviced By:

 **ELECTROMATE**

Toll Free Phone (877) SERV098

Toll Free Fax (877) SERV099

www.electromate.com

sales@electromate.com

AC Input Step Drives w/ Controls

➤ Si2035	Packaged Programmable Drive with Integrated Power Supply	46
➤ Si3540	Packaged Programmable Drive with Integrated Power Supply	47
➤ Si5580	Packaged Programmable Drive with Integrated Power Supply	48

AC Input Step Drives

➤ PDO2035	Packaged Pulse & Direction/Oscillator Drive with Integrated Power Supply	52
➤ PDO3540	Packaged Pulse & Direction/Oscillator Drive with Integrated Power Supply	52
➤ PDO5580	Packaged Pulse & Direction/Oscillator Drive with Integrated Power Supply	53

Controls & Accessories

➤ SiNet™ Hub 444	4 Axis Programmable Hub	57
➤ SiNet™ Hub 8	8 Axis Programmable Hub	57
➤ PS430	Unregulated Power Supply	58
➤ PS1050	Unregulated Power Supply	58
➤ MMI	Operator Interface for use w/ "Si" Software	59
➤ BOB1/BOB2	Break Out Board	59
➤ RC-050	Regeneration Clamp	59

Step Motors

➤ NEMA 08		61
➤ NEMA 11		62
➤ NEMA 14		62
➤ NEMA 17 - High Torque		63
➤ NEMA 23		64
➤ NEMA 23 w/ Cable		65
➤ NEMA 23 - High Torque		66
➤ NEMA 23 - High Torque w/ Cable		67
➤ NEMA 34		68
➤ NEMA 34 w/ Cable		69
➤ NEMA 34 - High Torque		69/70
➤ NEMA 34 - High Torque w/ Cable		71
➤ Wiring Diagrams		73-74
➤ Step Motors Encoders		75
➤ Modifications / Options		75

Sold & Serviced By:



Toll Free Phone (877) SERV099
Toll Free Fax (877) SERV099

www.electromate.com
sales@electromate.com



Servo Drives

➤ BluDC4	Open frame DC input Servo Drive	79
➤ BluDC9	Packaged DC input Servo Drive	80
➤ BluAC5	Packaged AC input Servo Drive	82

Servo Drive Accessories

➤ RC-050	Regeneration Clamp	87
➤ RA-100	Regeneration Resistor	87
➤ BOB1/BOB2	Breakout Board	87

Servo Cables

➤ All Servo Cables		88
---------------------------	--	-----------

Servo Motors

➤ Part Numbering System	Overview	91
➤ N Series NEMA 17	High Performance Servo Motors	92
➤ N Series NEMA 23	High Performance Servo Motors	93
➤ N Series NEMA 34	High Performance Servo Motors	94
➤ M Series 40mm	High Performance Servo Motors	95
➤ M Series 60mm	High Performance Servo Motors	96
➤ M Series 80mm	High Performance Servo Motors	97
➤ M Series 100mm	High Performance Servo Motors	98
➤ A Series 80mm	High Performance Servo Motors	99
➤ V Series	Low Cost Servo Motors	100
➤ Holding Brake Specs		101
➤ Motor Phase Excitation		101
➤ Encoder Connections		101
➤ Motor Connections		102
➤ E.D.C.M. Explanation		102

Gearheads

➤ Gearheads		103
--------------------	--	------------

Sold & Serviced By:



Toll Free Phone (877) SERV098
Toll Free Fax (877) SERV099
www.electromate.com
sales@electromate.com

MOTION CONTROL SINCE 1978

Applied Motion Products began in 1978 with a handful of step motor customers in the Silicon Valley disk drive business. Today, Applied Motion serves a wide variety of industrial markets with a comprehensive offering of integrated motion control systems.

- Servo Drives & Motors
- Stepper Drives & Motors
- Position Controllers
- Integrated Software
- Precision Gearheads



The right choice for your precision positioning needs:

A keen focus on the precise needs of our customers is key to our continuing success. Our trained, high tech distributors provide local sales and service support to users and OEMs.



APPLICATIONS EXPERIENCE

Applied Motion has application experience across a wide variety of industries. Having solved hundreds of complex problems in motion control with both standard and custom solutions, new products are driven by customer application needs. Success is measured by our customers' growth.



FLEXIBILITY

Applied Motion does not take the "one size fits all" approach. Our engineers tailor our products form, fit and function. Applied Motion works out the details to meet or exceed our customer's schedules, delivery needs and packaging requirements.



NIMBLE/FAST

Often, response time can make the difference between success and disappointment in a project. Applied Motion understands the realities that a quick decision and prototype can mean to a successful outcome.



INNOVATIVE/RECEPTIVE

Open discussion and a lively exchange of ideas encourage Applied Motion to meet and exceed our mutual goals.



SUPPORT NETWORK

To ensure continuing customer success, Applied Motion has put together a world class support system including Interactive Training Tools and telephone and on-site assistance.

AGENCY APPROVALS

As AMP develops new products we are customer driven to meet agency approvals and industry standards (RoHS, CE, UL). As we constantly invent our own product future, testing and certification are a critical part of the process.

Sold & Serviced By:



Toll Free Phone (877) SERV098

Toll Free Fax (877) SERV099

www.electromate.com

sales@electromate.com



Distributors

QUICKLINK: DIST

Applied Motion Products Worldwide Distributor Network

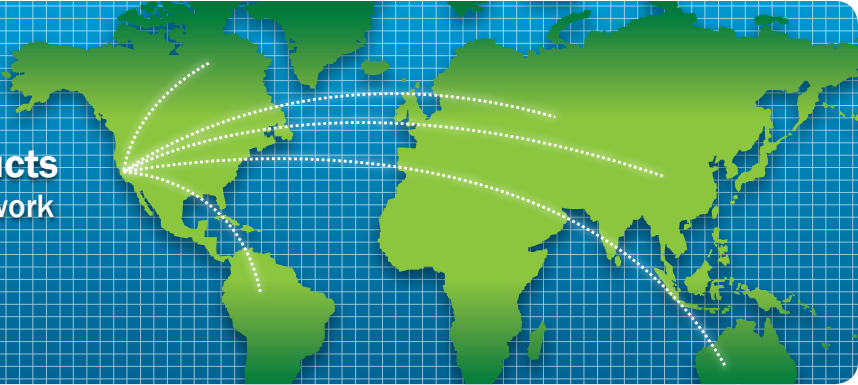

WORLDWIDE NETWORK

Applied Motion has a network of Distributors and Sales Partners throughout the Globe, our ASP (Automation Solution Providers) specialize in specifying, selling and supporting our products to a wide variety of industries.

Our distributors are located in the following regions:

- North America
 - USA - North East
 - USA - South East
 - USA - North West
 - USA - Mid West
 - USA - South West
 - USA - West
- Canada
- Central America
- South America
- Europe
- Asia

To find an ASP/distributor near you please visit our website:
www.applied-motion.com/distributors

Sold & Serviced By:

 **ELECTROMATE**

Toll Free Phone (877) SERV098

Toll Free Fax (877) SERV099

www.electromate.com

sales@electromate.com

SOFTWARE

Software

Advanced Application Software Solutions



EASE OF SETUP IS OUR PRIORITY

Our goal is to make the setup & programming of motion systems as easy as possible. We include all the software tools needed to setup, calibrate, and configure your Applied Motion system. All software downloads and updates are provided to our customers at no charge.



SI PROGRAMMER™

Intended for use in stand-alone applications, Si Programmer™ provides a friendly, point-and-click, graphical interface that doesn't require any previous programming experience.

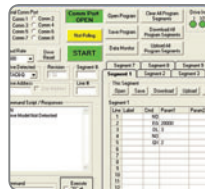

Q PROGRAMMER™

Used to create and edit stand-alone programs for Q-compatible drives. The functions of these drives include multi-tasking, math, register manipulation, encoder following, and more.



CONFIGURATOR™

Used for setup and configuration with the ST and STAC6 drives. Configurator™ gives an easy path to setting all the drive parameters.



QUICK TUNER™

Quick Tuner™ is used for the configuration and tuning of AMP servo drives.



SINET™ HUB PROGRAMMER

The SiNet™ Hub Programmer™ is the multi-axis version of the Si software. It is used with the hubs to create multi-axis systems.

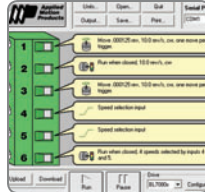

EXPOSITION™

If you're using the 2035XD two axis drive, you'll need eXposition™ to configure it.

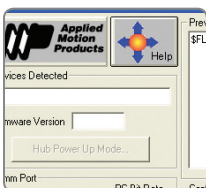

SCL™ SETUP UTILITY

The SiNet™ Command Language is a set of ASCII commands that can be streamed to the drive via the serial port.

Sold & Serviced By:

 **ELECTROMATE**

Toll Free Phone (877) SERV098
 Toll Free Fax (877) SERV099
www.electromate.com
sales@electromate.com



Si Programmer™ - PROGRAM YOUR SI COMPATIBLE DRIVE

QUICKLINK: siprog



- ✓ Easy-to-use, icon-based programming environment
- ✓ Intuitive instructions for all levels of experience
- ✓ Quick setup and programming of all compatible drives
- ✓ Built-in functionality for optional operator interface (MMI)
- ✓ Built-in control of digital inputs and outputs

DESCRIPTION

Intended for use in stand-alone applications, Si (Simple Indexer) Programmer provides quick, out-of-the-box use with an extremely friendly, point-and-click graphical interface that does not require any software programming experience. Once an Si program has been composed and downloaded to an Si compatible drive, the program is executed stand-alone at power-up.

Constructing a program is accomplished through the use of instructions selected via point-and-click. Once an instruction is selected, a "fill in the blanks" format is used to input parameters. Creating an Si program requires no prior programming experience nor does it require learning a programming language. Si Programmer™ generates the actual motion control program, based on user selected parameters, thereby eliminating syntax errors. Once created, programs are easily downloaded, uploaded, saved and printed.

COMPATIBILITY

- ▶ BLuAC5-Si
- ▶ BLuDC9-Si
- ▶ BLuDC4-Si
- ▶ STAC6-Si
- ▶ STAC6-220-Si
- ▶ ST10-Si
- ▶ ST5-Si
- ▶ Si5580
- ▶ Si3540
- ▶ Si2035
- ▶ 7080i
- ▶ 3540i
- ▶ 1240i

An optional operator interface (MMI) provides an inexpensive method for inputting machine operating instructions like move length, move speed, and cycle count, as well as for selecting program branches and for decision making within a program. Si also provides the capability to control digital inputs and outputs, useful for interfacing with external equipment like PLCs, sensors, end-of-travel switches, and more. Si Programmer™ has found success in all types of applications, from simple linear actuators to complete machine control with operator interface applications. Si Programmer™ is available on both stepper and servo drives.

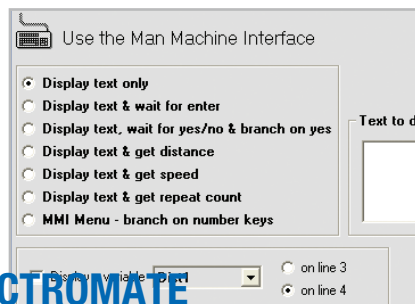
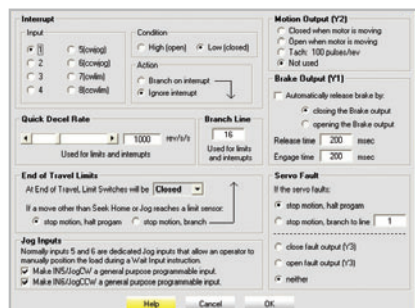
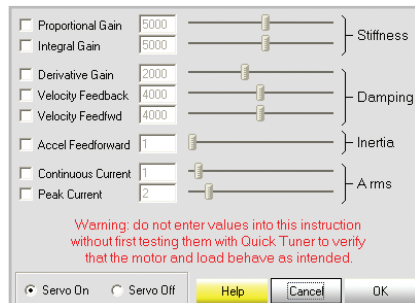

Sold & Serviced By:



Toll Free Phone (877) SERV098
 Toll Free Fax (877) SERV099
www.electromate.com
sales@electromate.com



FREE DOWNLOAD

Our software and user manuals can be downloaded from our website:

www.applied-motion.com/downloads

Q Programmer™

QUICKLINK: qprog

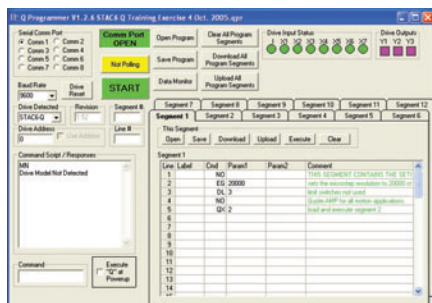

- ✓ Multi-tasking
- ✓ Math functions
- ✓ Stored program execution (stand-alone)
- ✓ DSP-based controller and single-axis drive in one package
- ✓ RS-232/485 ports for comm. with HMI's, PLC's, PC's, and more
- ✓ Manipulation of all drive parameters through internal registers

DESCRIPTION

Q Programmer™ is a single-axis motion control software for programmable servo and step motor drives from Applied Motion Products.

The software allows users to create sophisticated and functional programs that Q drives can run stand-alone. The commands available in the Q software environment consist of commands for controlling motion, inputs & outputs, drive configuration and status, as well as math operations, register manipulation and multi-tasking.

The Q Programmer™ software itself is simply a useful and user-friendly program editor that allows you to create, edit and store motion control programs for your Q-version drive. It also allows you to stream commands to the drive and monitor drive parameters and motor activity during start up of your application.

The real beauty of the Q software environment resides in the drive. Each Q drive is a stand-alone, single-axis drive and DSP-based motion controller in one package. Q drives have the ability to run their own stored programs while at the same time communicating with an external host device such as a PLC, HMI, PC, or other intelligent serial device, to continuously update register data, drive status, and motor activity.

COMPATIBILITY

- BLuAC5-Q
- BLuDC9-Q
- BLuDC4-Q
- STAC6-Q
- STAC6-220-Q
- ST10-Q
- ST5-Q

Sold & Serviced By:



Toll Free Phone (877) SERV098
Toll Free Fax (877) SERV099
www.electromate.com
sales@electromate.com



FREE DOWNLOAD

Our software and user manuals can be downloaded from our website:

www.applied-motion.com/downloads



STAC6 Configurator™

QUICKLINK: [stac6config](#)



- ✓ Simple drive setup
- ✓ Store and download configurations

DESCRIPTION

The STAC6 configurator is the software tool for setting up and configuring the STAC6 series drives. Follow the 5 basic steps to set up the motor, control options, and optional encoder. Then download the configuration to the drive.

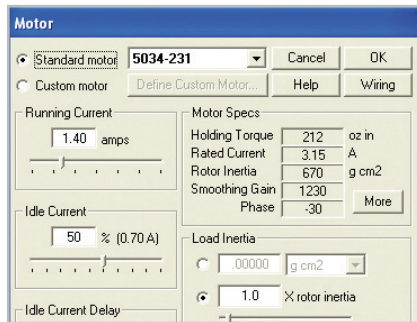

COMPATIBLE DRIVES

- STAC6-S
- STAC6-220-S
- STAC6-Q
- STAC6-220-Q

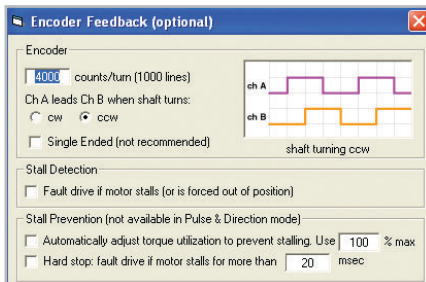
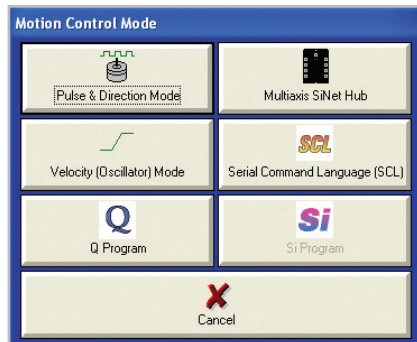

Sold & Serviced By:



Toll Free Phone (877) SERV098
Toll Free Fax (877) SERV099
www.electromate.com
sales@electromate.com



FREE DOWNLOAD

Our software and user manuals can be downloaded from our website:

www.applied-motion.com/downloads

ST Configurator™

QUICKLINK: stconfig



- ✓ Simple drive setup
- ✓ Store and download configurations

DESCRIPTION

The ST configurator™ is the software tool for setting up and configuring the ST series drives. Follow the 5 basic steps to set up the motor, control options, and optional encoder. Then download the configuration to the drive.

COMPATIBLE DRIVES

- ST5-S
- ST10-S
- ST5-Q
- ST10-Q

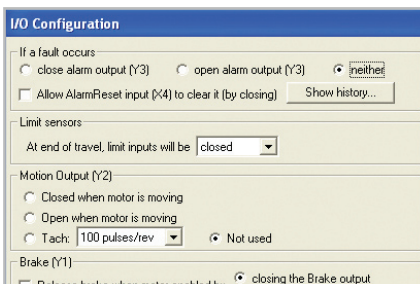
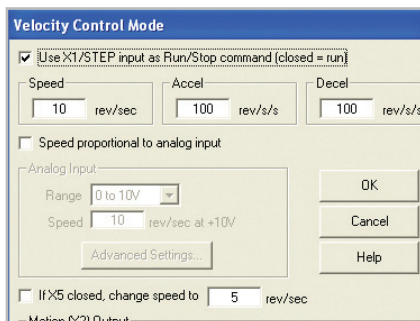

Sold & Serviced By:

 **ELECTROMATE**

Toll Free Phone (877) SERV098

Toll Free Fax (877) SERV099

www.electromate.com

sales@electromate.com



FREE DOWNLOAD

Our software and user manuals can be downloaded from our website:

www.applied-motion.com/downloads



Quick Tuner™

QUICKLINK: quicktuner

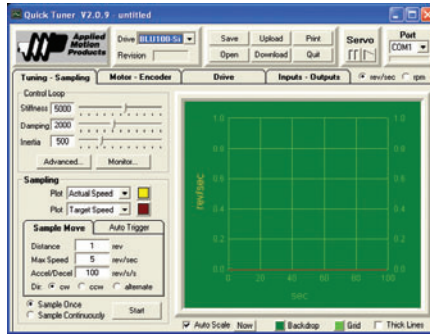

- ✓ Servo configuration software
- ✓ Tune servo response
- ✓ Display response in real time
- ✓ Set-up I/O

DESCRIPTION

Quick Tuner™ is the configuration software for all Applied Motion Servo Drives. It enables the user to setup the drive and its parameters and optimize motor performance.

Tuning is simple, just select the Parameter File for your motor and load it into the system. Download to the drive and in most cases you are ready to go.

The graphical screens will change according to the drive model connected, allowing the user to select only the options available to them.

To fine tune the system there is an oscilloscope function allowing the user to enter a move and view the system response, the gains can then be adjusted to optimize system performance.

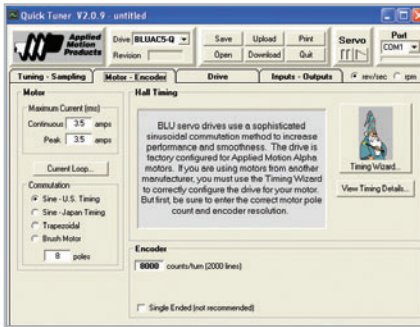

COMPATIBLE DRIVES

- BLuDC4-S
- BLuDC4-Q
- BLuDC9-S
- BLuDC9-Q
- BLuAC5-S
- BLuAC5-Q

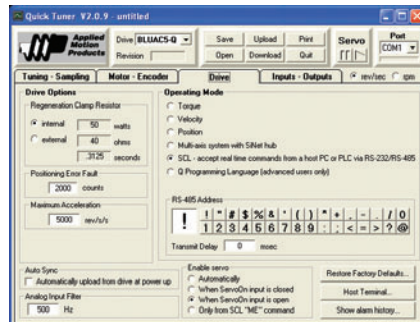

Sold & Serviced By:



Toll Free Phone (877) SERV098
 Toll Free Fax (877) SERV099
www.electromate.com
sales@electromate.com



FREE DOWNLOAD

Our software and user manuals can be downloaded from our website:

www.applied-motion.com/downloads

SiNet™ Hub Programmer

QUICKLINK: sinethub

Software

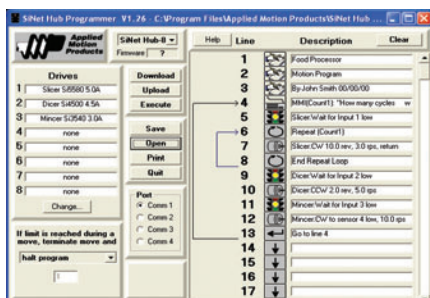

- ✓ Control up to 8 axes
- ✓ Control and use I/O on all connected drives
- ✓ Multi-tasking

DESCRIPTION

SiNet™ Hub Programmer is used with the SiNet™ Hub 8 or the Hub 444, to create multi-axis systems using Applied Motion's Si, i, and S series drives.

Up to 8 drives can be connected to the hubs with the cables supplied. The system can accept stepper or servo drives, or a mixture of both. The software can scan the network to determine which drives are connected.

Then using the simple point-and-click approach, as used in the Si programmer™, the user develops his program sequence, assigning moves and commands to each axis. The system can utilize the I/O present on all the axes connected to the hub.

COMPATIBLE PRODUCTS

- SiNet™ Hub 444
- SiNet™ Hub 8

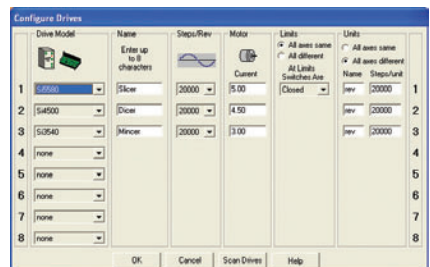
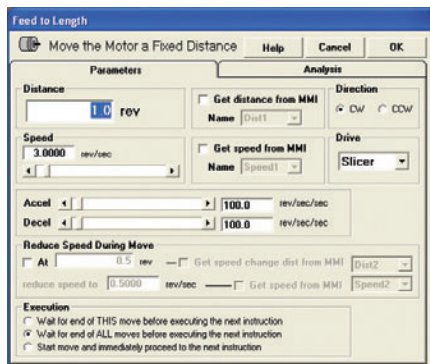
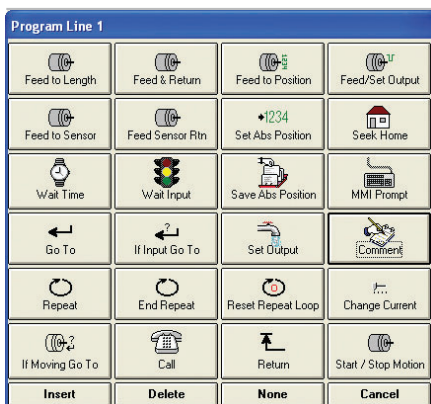

Sold & Serviced By:

 **ELECTROMATE**

Toll Free Phone (877) SERV098
 Toll Free Fax (877) SERV099
www.electromate.com
sales@electromate.com



FREE DOWNLOAD

Our software and user manuals can be downloaded from our website:

www.applied-motion.com/downloads



SCL™ Setup Utility

QUICKLINK: scl

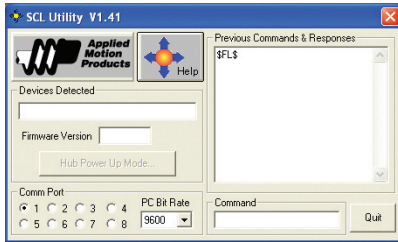

- ✓ Simple terminal program to execute SCL™ commands
- ✓ Test and verify instructions

DESCRIPTION

The SCL™ (SiNet™ Command Language) Setup Utility is a small terminal program that enables the user to stream SCL commands directly to the drive.

SCL™ commands are serial commands designed to be incorporated into the user's host system. The SCL™ Setup Utility is intended to assist with the test and verification of the commands and their operation.

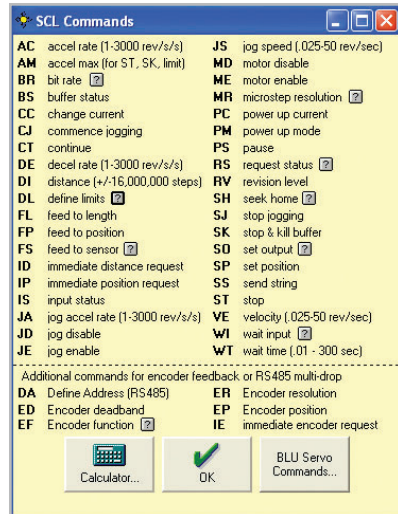

COMPATIBLE DRIVES

- 1240i
- 3540i
- 7080i
- Si2035
- Si3540
- Si5580
- All BLuAC5 models
- All BLuDC9 models
- All BLuDC4 models
- All ST Series models
- All STAC6 Series models

Sold & Serviced By:



Toll Free Phone (877) SERV098
 Toll Free Fax (877) SERV099
www.electromate.com
sales@electromate.com



FREE DOWNLOAD

Our software and user manuals can be downloaded from our website:

www.applied-motion.com/downloads

DC Input Step Drives

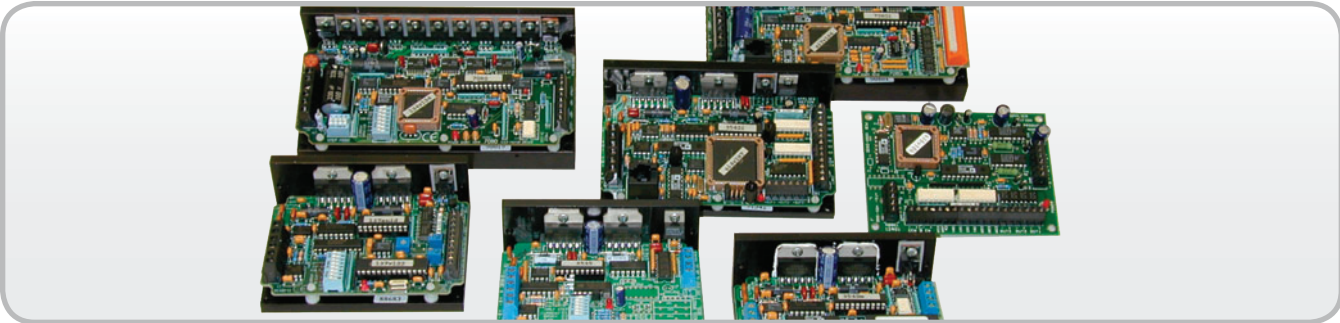

Applied Motion Step Drives are ideal for OEM applications. Our low cost, simple to use drives provide extended service life and value second to none.

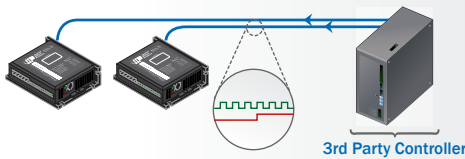

STEP & DIRECTION

The Controller sends Pulse & Direction signals to each drive. The functionality and number of axes controlled will depend on the controller.



OSCILLATOR MODE

An internal oscillator develops a speed signal, allowing the drive to run at a pre-configured velocity. In some cases the velocity can be varied by an analog control signal.

Sold & Serviced By:

 **ELECTROMATE**

Toll Free Phone (877) SERV098

Toll Free Fax (877) SERV099

www.electromate.com

sales@electromate.com

2035 - LOW COST STEP AND DIRECTION INPUT DRIVE

QUICKLINK: 2035

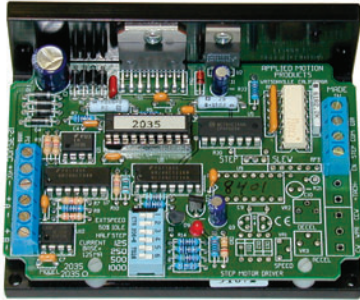

SPECIFICATIONS

Output Current: **0.125 - 2.0A**
DC Bus Voltage: **12 - 35 VDC**

WEIGHT
9.0 oz



FEATURES

- ↘ Step & Direction
5-24V NPN or PNP
- ↘ Full & Half Step
Switch selectable
- ↘ Idle Current Reduction
0 or 50%
- ↘ Screw Terminals
- ↘ Dip Switch Setup
- ↘ Enable Input
- ↘ Opto-isolated inputs

RECOMMENDED MOTORS

- HT11-013
- 5014-842
- HT17-075
- HT23-394

This is a selection of the suitable motors for this drive. For more options visit the website.

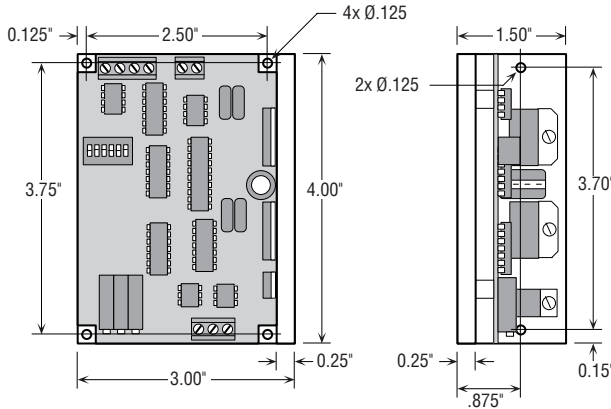

Torque curves on page 20

2035-O - LOW COST STEP MOTOR DRIVE WITH OSCILLATOR

QUICKLINK: 2035o

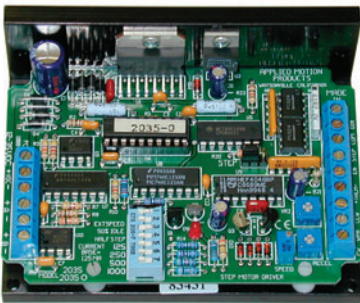

SPECIFICATIONS

Output Current: **0.125 - 2.0 A**
DC Bus Voltage: **12-35 VDC**

WEIGHT
9.0 oz



FEATURES

- ↘ On board Oscillator
- ↘ Full & Half Step
5-24V NPN or PNP
- ↘ Idle Current Reduction
0 or 50%
- ↘ Screw Terminals
- ↘ Dip Switch Setup
- ↘ Analog Speed Adjustment
- ↘ Tach Output
5-24v pulse output
- ↘ Enable Input
- ↘ Run/stop and direction inputs
- ↘ Opto-isolated inputs

RECOMMENDED MOTORS

- HT11-013
- 5014-842
- HT17-075
- HT23-394

This is a selection of the suitable motors for this drive, for more options visit the website

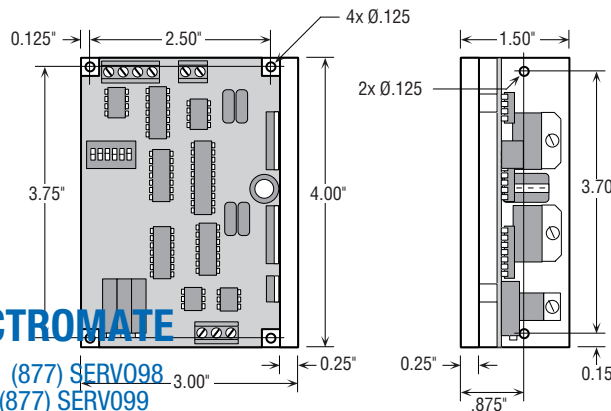

Torque curves on page 20

Sold & Serviced By:



Toll Free Phone (877) SERV098
Toll Free Fax (877) SERV099
www.electromate.com
sales@electromate.com

2035-XD - DUAL AXIS MICROSTEPPING STEP AND DIRECTION INPUT / OSCILLATOR DRIVE

QUICKLINK: 2035xd

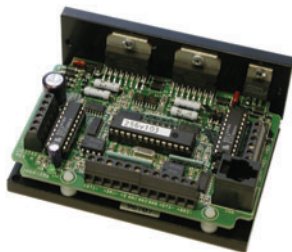

SPECIFICATIONS

Output Current: **0.1 - 2.0 A**
 DC Bus Voltage: **12-35 VDC**

WEIGHT
 9.3 oz

FEATURES

- ↘ Dual-Axis - independent control of two motors
- ↘ Step & Direction / Oscillator
- ↘ Generates step pulses and accel/decel ramps
- ↘ Software programmable microstepping
 200 - 50,800 Steps/Rev
- ↘ Automatic Idle Current Reduction
- ↘ Two analog Inputs - Screw Terminals
 5V logic, 10 bit resolution , 0-5 VDC
- ↘ Four optically isolated digital inputs
 step/run 1, step/run 2, direction 1, direction 2 .
- ↘ Digital Output
 30VDC 100mA max

SOFTWARE

- ↘ eXposition Setup Software
 Software and programming cables supplied

RECOMMENDED MOTORS

- HT11-013
- 5014-842
- HT17-075
- HT23-394

This is a selection of the suitable motors for this drive. For more options visit the website.

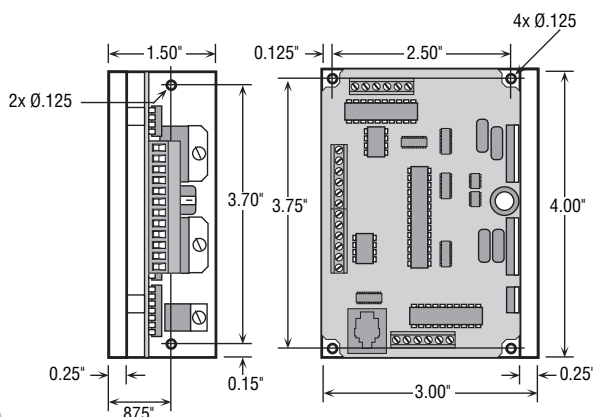

Torque curves on page 20 →

3535 - LOW COST STEP AND DIRECTION INPUT DRIVE

QUICKLINK: 3535

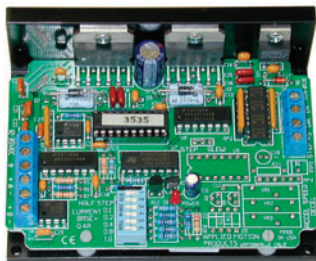

SPECIFICATIONS

Output Current: **0.4 - 3.5 A**
 DC Bus Voltage: **12 - 35 VDC**

WEIGHT
 9.2 oz



FEATURES

- ↘ Step & Direction
 5V logic
- ↘ Full & Half Step
- ↘ Idle Current Reduction
 0 or 50%
- ↘ Screw Terminals
- ↘ Dip Switch Setup
- ↘ Enable input
- ↘ Opto-isolated inputs

RECOMMENDED MOTORS

- HT11-013
- 5014-842
- HT17-075
- HT23-394

This is a selection of the suitable

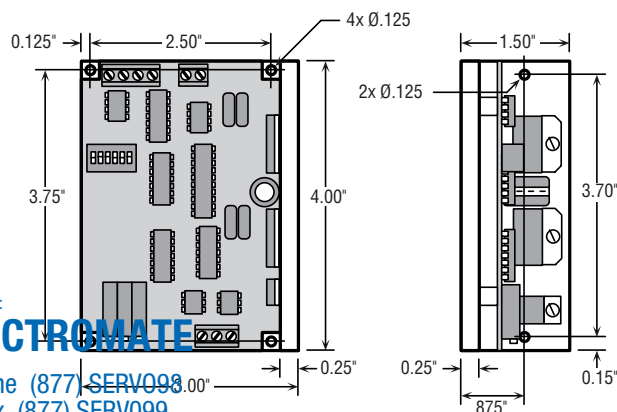

Torque curves on page 21 →

Sold & Serviced By:



Toll Free Phone (877) SERV098
 Toll Free Fax (877) SERV099
www.electromate.com
sales@electromate.com

3535-O - STEP MOTOR DRIVE WITH/ OSCILLATOR

QUICKLINK: 3535o

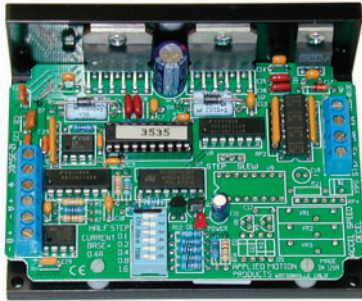

SPECIFICATIONS

Output Current: **0.4 - 3.5 A**
 DC Bus Voltage: **12 - 35 VDC**

WEIGHT

9.2 oz



FEATURES

- ↘ On board Oscillator
- ↘ Generates step pulses and accel/decel ramps
- ↘ Run/stop , dir inputs
- ↘ 5v logic
- ↘ Full & Half Step
- ↘ Idle Current Reduction
- ↘ 0 or 50%
- ↘ Screw Terminals
- ↘ Analog Speed Adjustment
- ↘ Enable Input

RECOMMENDED MOTORS

- HT11-013
- 5014-842
- HT17-075
- HT23-394

This is a selection of the suitable motors for this drive.
 For more options visit the website.

Visit: www.applied-motion.com for torque curves and other tech data.

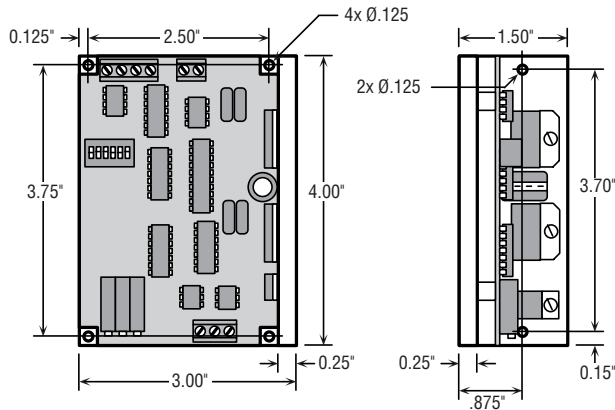

Torque curves on page 21

3540M - MICROSTEPPING / STEP & DIRECTION INPUT DRIVE

QUICKLINK: 3540m



SPECIFICATIONS

Output Current: **3.5 A**
 DC Bus Voltage: **12-42 VDC**

WEIGHT

9.5 oz



FEATURES

- ↘ Step & Direction
- ↘ Optically isolated 5 VDC inputs for step, direction and enable
- ↘ Microstepping
- ↘ 400, 1000, 2000, 12800 steps/rev. Other resolutions are available upon request
- ↘ Idle Current Reduction
- ↘ 50%
- ↘ Enable input
- ↘ (turn off current to the motor)
- ↘ Screw Terminals
- ↘ Self test

RECOMMENDED MOTORS

- HT17-075
- HT23-394
- HT23-397
- HT23-400

This is a selection of the suitable motors for this drive.
 For more options visit the website.

Visit: www.applied-motion.com for torque curves and other tech data.

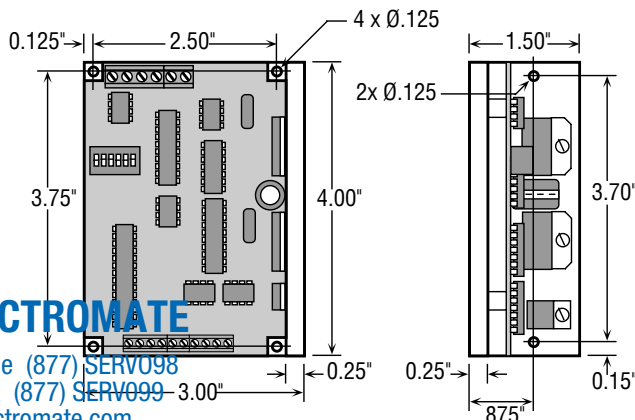

Torque curves on page 21

Sold & Serviced By:



Toll Free Phone (877) SERV098
 Toll Free Fax (877) SERV099
www.electromate.com
sales@electromate.com

3540MO - STEP MOTOR DRIVE WITH OSCILLATOR

QUICKLINK: 3540mo

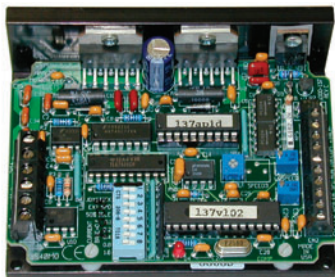

SPECIFICATIONS

Output Current: **0.4 - 3.5 A**
DC Bus Voltage: **12 - 42 VDC**

WEIGHT

9.5 oz



FEATURES

- Oscillator
- Microstepping
12,800 Steps / Rev
- Idle Current Reduction
50%
- RUN/STOP and Direction inputs
5v logic
- High speed and Low speed range
5rps - 25 rps
- Enable input, tach output
5-24V optically isolated, 100 pulses per revolution
- Internal Potentiometer
Accel/decel (1-250 rev/sec/sec, Low speed (0-5 rps), High speed (0-25 rps)
- External Speed control
Pot or Joystick 3 terminal type, 1k-10k ohms

RECOMMENDED MOTORS

- HT11-013
- 5014-842
- HT17-075
- HT23-394

This is a selection of the suitable motors for this drive. For more options visit the website.

Torque curves on page 21 

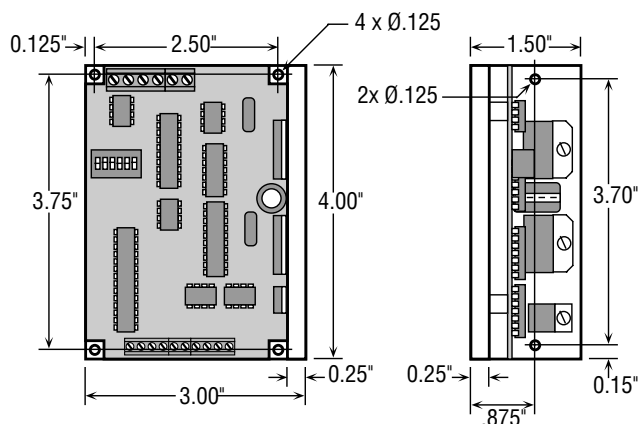

7080 - HIGH POWERED STEP AND DIRECTION INPUT DRIVE

QUICKLINK: 7080



SPECIFICATIONS

Output Current: **0.8 - 7.0 A**
DC Bus Voltage: **24 - 80 VDC**

WEIGHT

1.0 lb



FEATURES

- Step & Direction
5-12v (24 possible)
- Microstepping
200 to 50800 steps / rev
- Idle Current Reduction
50%
- Screw Terminals
- Dip Switch Setup
- Enable Input
- Short Circuit & Thermal Protection
- Optically isolated
5-24 VDC inputs for step, direction and enable

RECOMMENDED MOTORS

- HT23-395
- HT23-401
- HT34-474
- HT34-478

This is a selection of the suitable motors for this drive. For more options visit the website.

Torque curves on page 22 

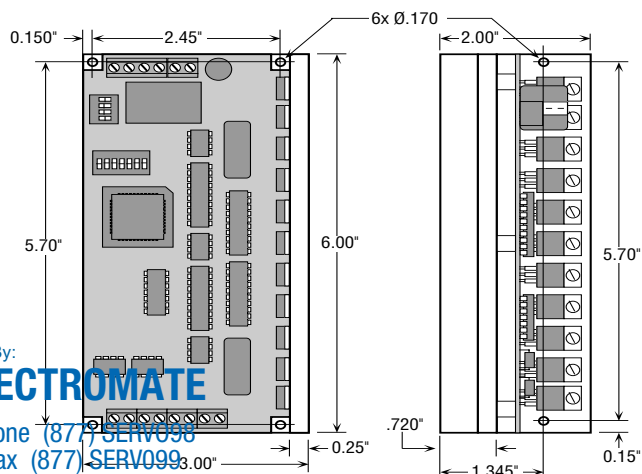

Sold & Serviced By:

 **ELECTROMATE**

Toll Free Phone (877) 517-0038

Toll Free Fax (877) 517-0099

www.electromate.com

sales@electromate.com



2035 / 2035-O - TORQUE CURVES

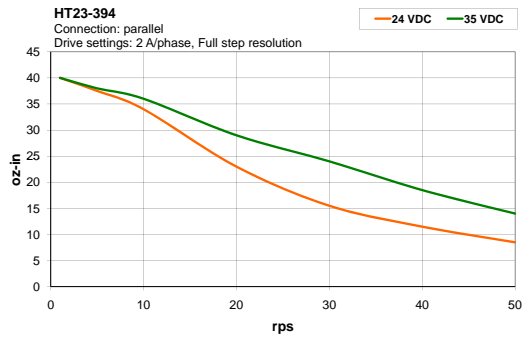
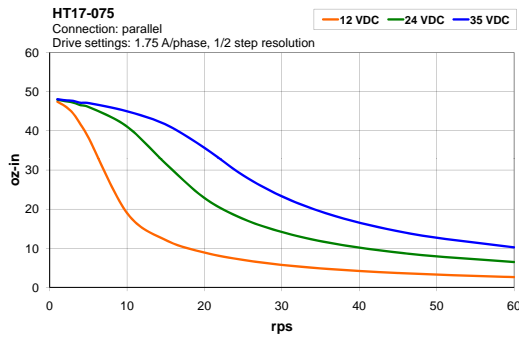
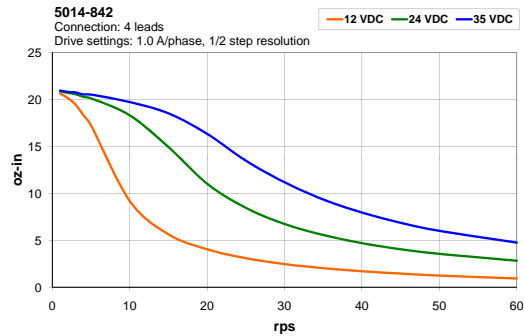
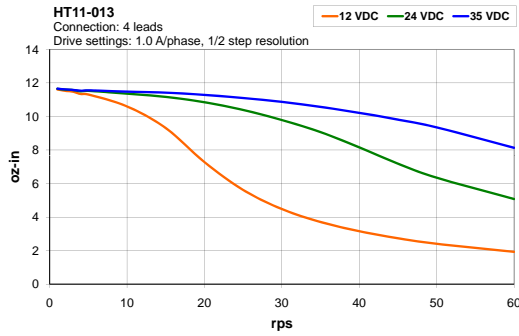

2035XD - TORQUE CURVES

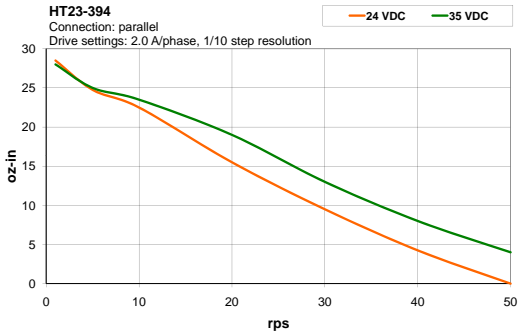
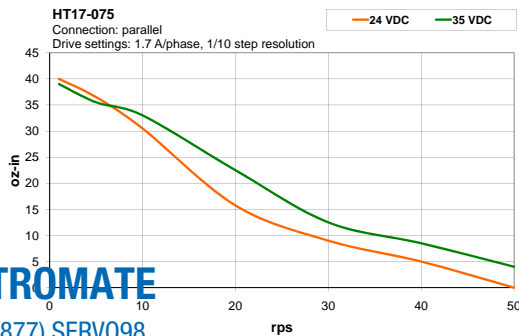
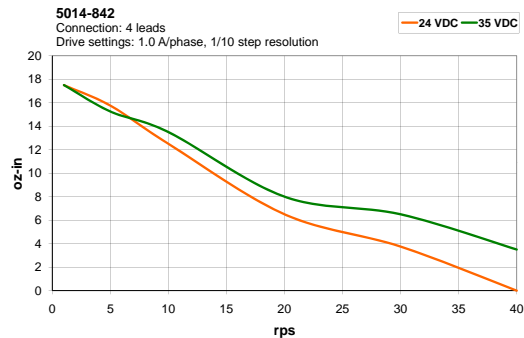
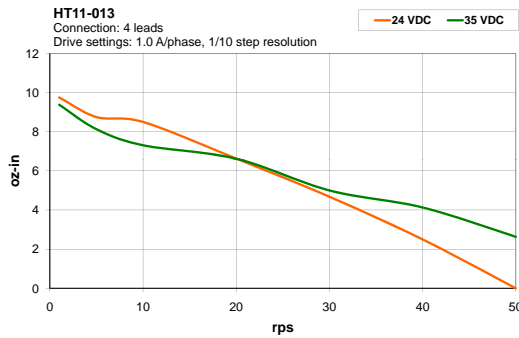

Sold & Serviced By:



Toll Free Phone (877) SERV098

Toll Free Fax (877) SERV099

www.electromate.com

sales@electromate.com

3535 / 3535-O - TORQUE CURVES

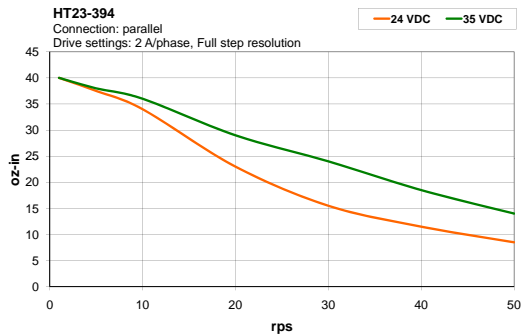
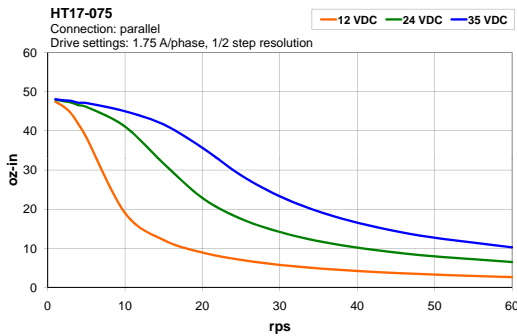
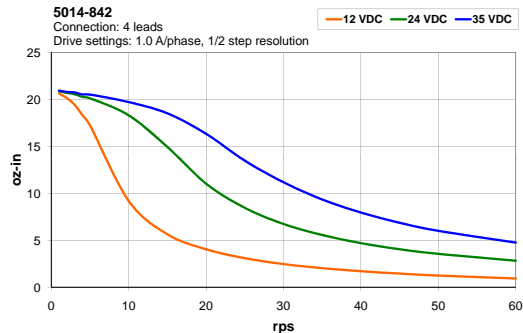
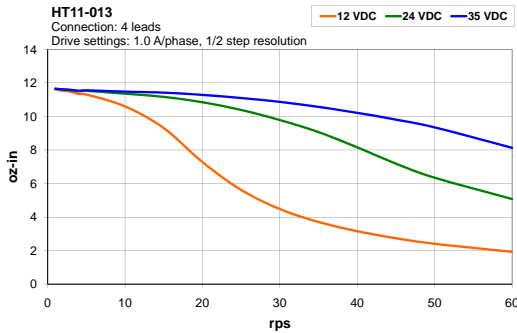

3540M / 3540MO - TORQUE CURVES

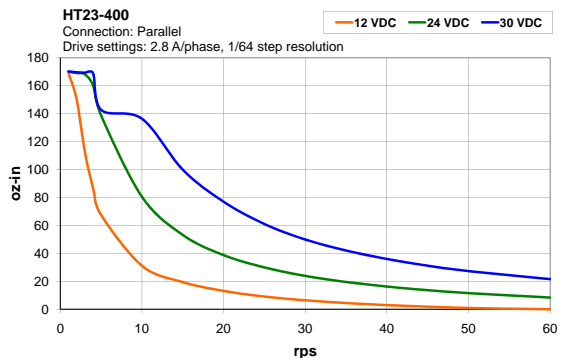
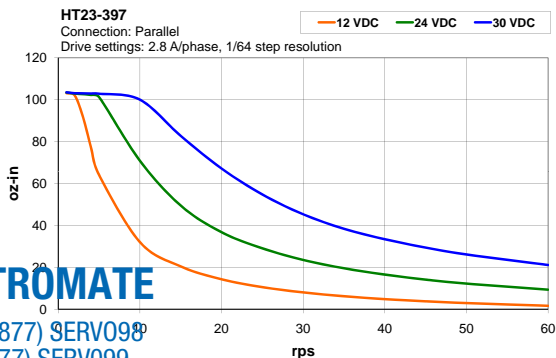
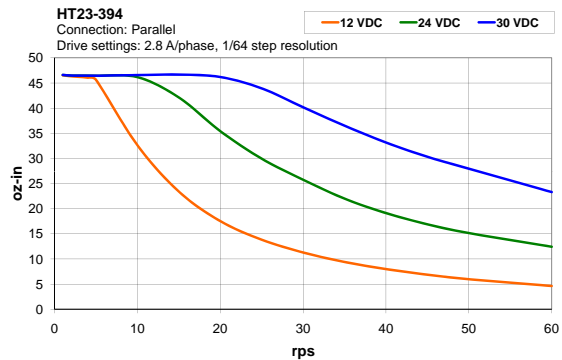
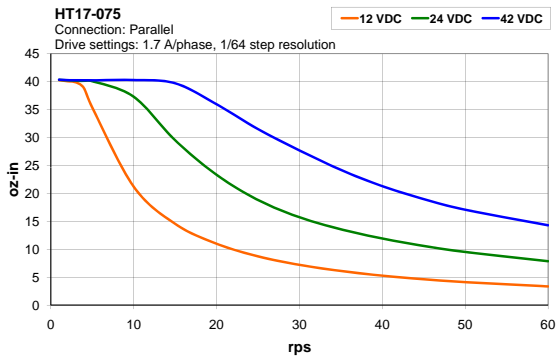

Sold & Serviced By:



Toll Free Phone (877) SERV098
 Toll Free Fax (877) SERV099
www.electromate.com
sales@electromate.com

7080 - TORQUE CURVES

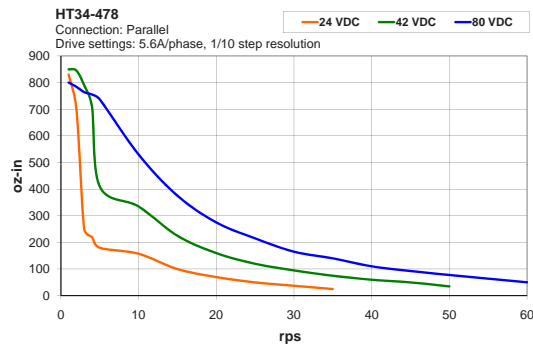
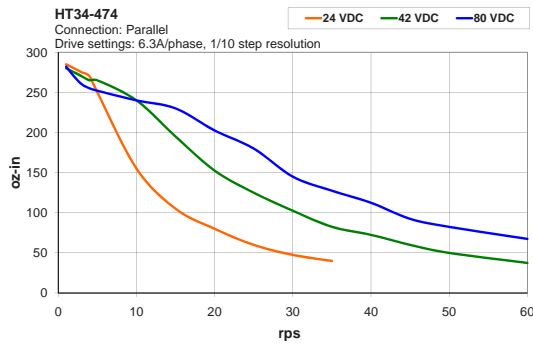
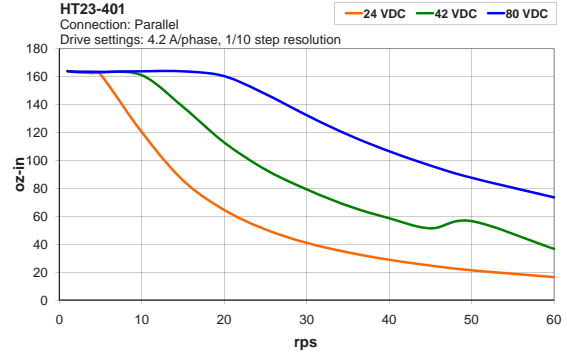
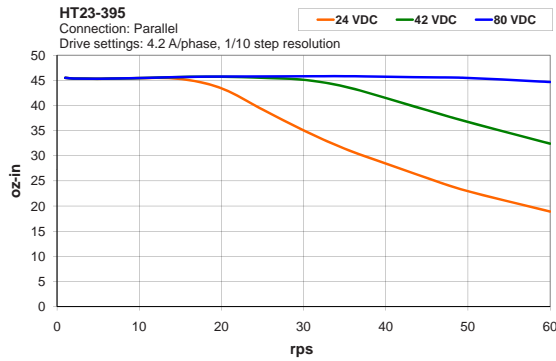

Sold & Serviced By:

ELECTROMATE

Toll Free Phone (877) SERV098

Toll Free Fax (877) SERV099

www.electromate.com

sales@electromate.com

DC Input Step Drives with Controls

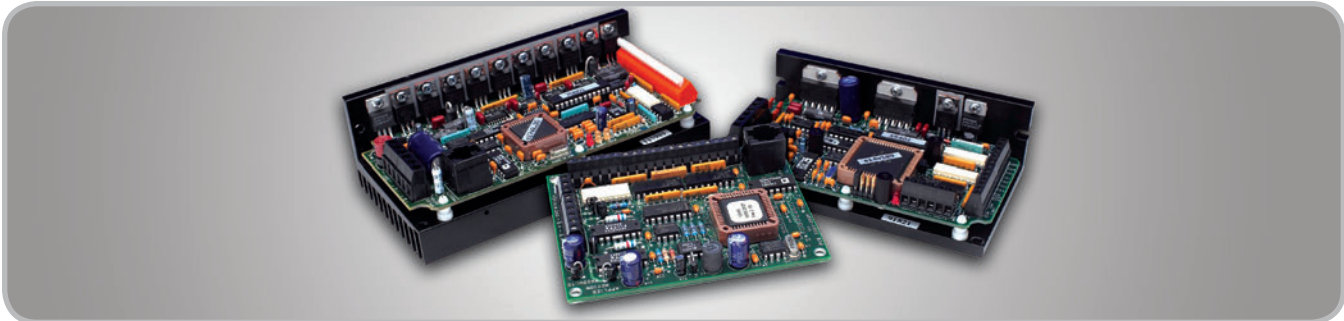

Applied Motion Product's programmable drives feature our Si Programmer™ software for simple “point and click” programming. These drives can also be used in host based systems using SCL™ command language



SI PROGRAMMER™

Si Programmer™ can be used to create complex sequences of events in a simple graphical icon based programming environment. No programming language to learn, just choose the motion icon and fill in the numbers and values.

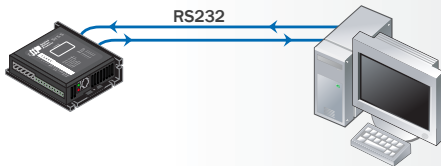

SCL™ (HOST CONTROL)

Intelligent drives can be used as part of a host controlled system. Instructions can be streamed via an RS232 port. Multi-drop RS485 communications are also available as an option on the 3540i drive (order 1000-175 daughter board) and the 1240i-485.

Sold & Serviced By:

 **ELECTROMATE**

Toll Free Phone (877) SERV098

Toll Free Fax (877) SERV099

www.electromate.com

sales@electromate.com

1240i - PROGRAMMABLE STEP MOTOR DRIVE

QUICKLINK: 1240i

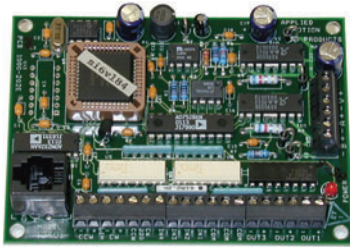

Si Programmable

SCL Compatible

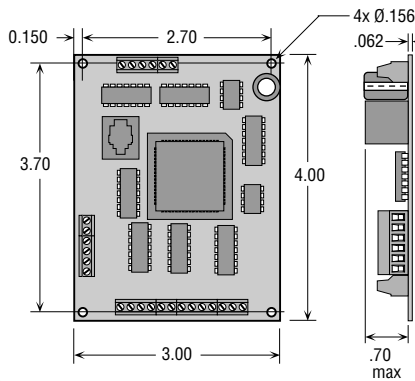

SPECIFICATIONS

Output Current: **0.2 - 1.2A**
DC Bus Voltage: **12 - 42VDC**

OPTIONS

↘ RS485 version available
(PN 1240i-485)

WEIGHT
2.6 oz

SOFTWARE

↘ Si Programmer™
Download, store and execute programs.
↘ SCL™ Setup Utility
Stream serial commands.

FEATURES

- ↘ Microstepping
Software selectable step resolution
2000 - 50800 steps/rev
- ↘ Idle Current
0%,25%,50%,100%
- ↘ Programmable motor current
- ↘ 8 User programmable inputs
5-24V NPN or PNP configurable
- ↘ 3 optically isolated outputs
24v 100 mA max
- ↘ Screw Terminals

Software and programming cables supplied. Go to page 8 for more info.

RECOMMENDED MOTORS

- HT11-013
- 5014-842
- HT17-075
- HT23-394

This is a selection of the suitable motors for this drive. For more options visit the website.

Torque curves on page 26 →

3540i - PROGRAMMABLE STEP MOTOR DRIVE

QUICKLINK: 3540i

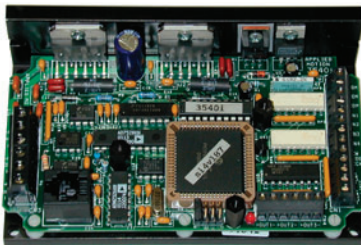

Si Programmable

SCL Compatible

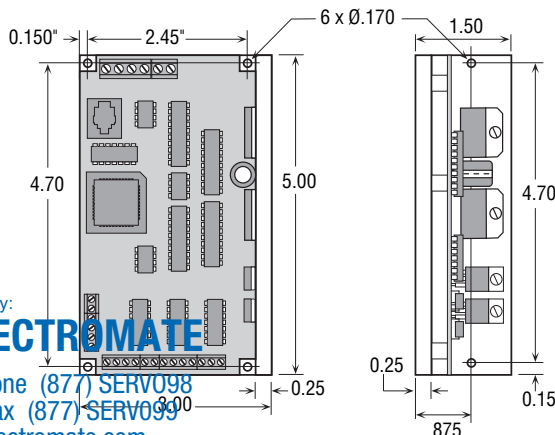

SPECIFICATIONS

Output Current: **3.5 A**
DC Bus Voltage: **12 - 42 VDC**

WEIGHT
11.7 oz

SOFTWARE

↘ Si Software™
Download, store and execute programs.
↘ SCL™ Setup Utility
Stream serial commands.

FEATURES

- ↘ Microstepping
Software selectable step resolution
2000 to 50800 steps/rev
- ↘ Idle Current
0%,25%,50%,100%
- ↘ Programmable motor current
- ↘ 8 User programmable inputs
5-24V NPN or PNP configurable
- ↘ 3 optically isolated outputs
24v 100 mA max
- ↘ Screw Terminals

OPTIONS

↘ RS485/Encoder Feedback board
(PN 1000-175)

RECOMMENDED MOTORS

- HT17-075
- HT23-394
- HT23-397
- HT23-401

This is a selection of the suitable motors for this drive. For more options visit the website.

Torque curves on page 26 →

Sold & Serviced By:



Toll Free Phone (877) SERV098
Toll Free Fax (877) SERV099
www.electromate.com
sales@electromate.com

7080i - PROGRAMMABLE STEP MOTOR DRIVE

QUICKLINK: 7080i



SPECIFICATIONS

Output Current - **0.5-7.0 A**
DC Bus Voltage - **24-80 VDC**

WEIGHT

1.1 lb



Si Programmable

SCL Compatible

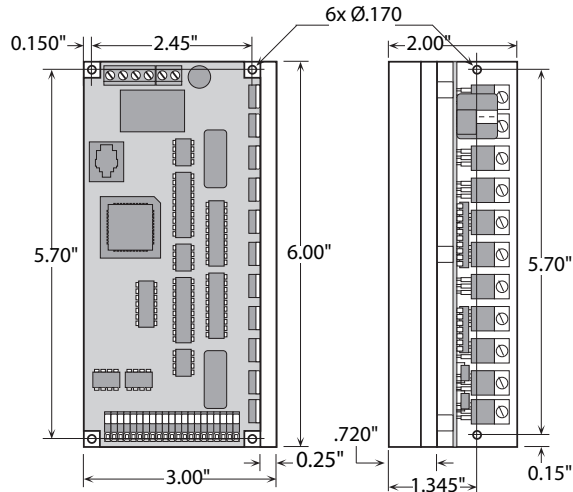

FEATURES

- ↘ Microstepping
- ↘ Software selectable step resolution
2000 to 50800 steps/rev
- ↘ Idle Current Reduction
0%,25%,50%,100%
- ↘ Programmable motor current
- ↘ 8 User programmable inputs
5-24V NPN or PNP configurable
- ↘ 3 optically isolated outputs
24v 100 mA max

SOFTWARE

- ↘ Si Programmer™
Download, store and execute programs.
- ↘ SCL™ Setup Utility
Stream serial commands.
Software and programing cables supplied.

RECOMMENDED MOTORS

- ↘ HT23-395
- ↘ HT23-401
- ↘ HT34-474
- ↘ HT34-478

This is a selection of the suitable motors for this drive.
For more options visit the website.

Torque curves on page 27

Sold & Serviced By:

ELECTROMATE

Toll Free Phone (877) SERV098

Toll Free Fax (877) SERV099

www.electromate.com

sales@electromate.com



1240i -TORQUE CURVES

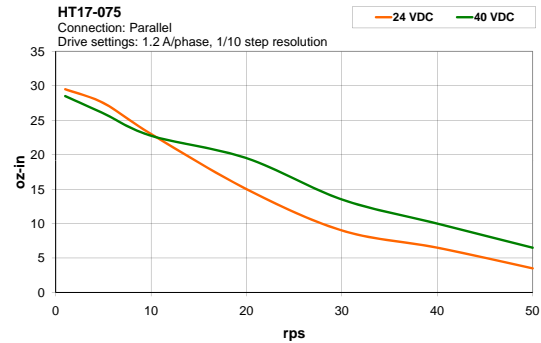
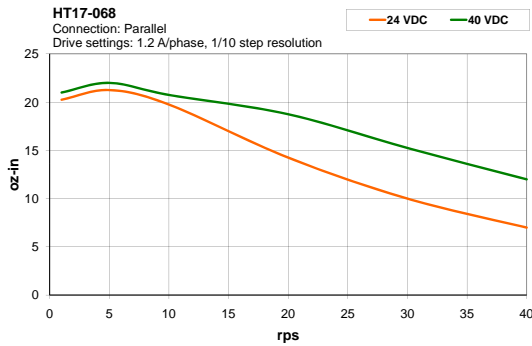
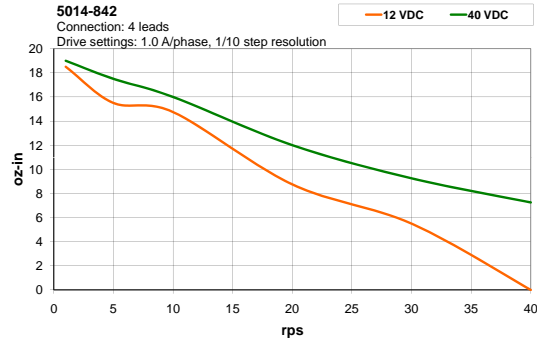
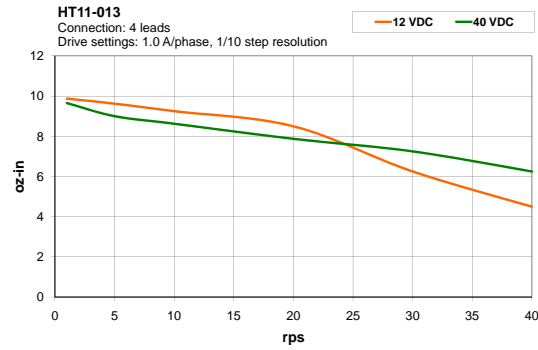

3540i -TORQUE CURVES

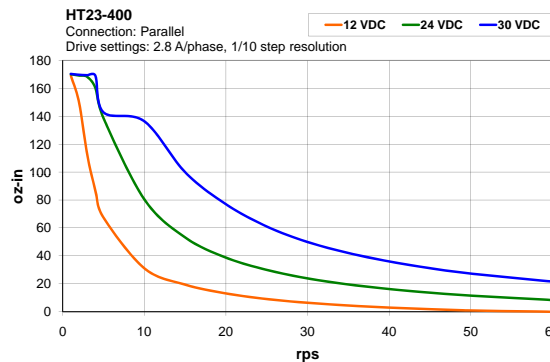
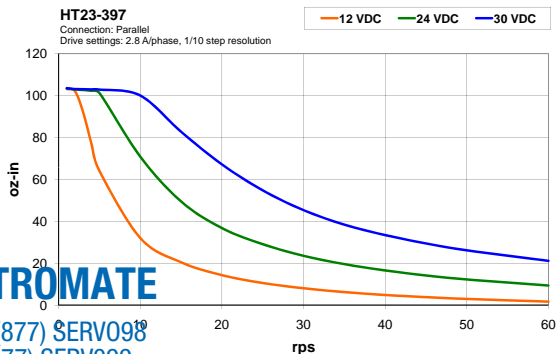
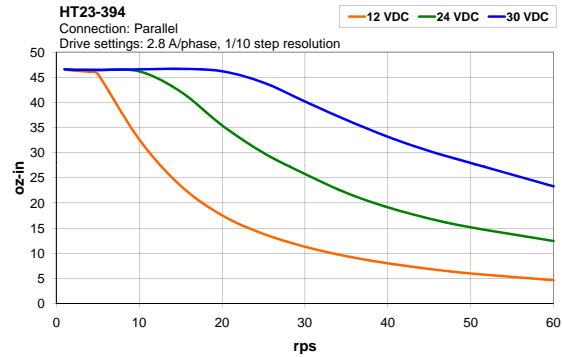
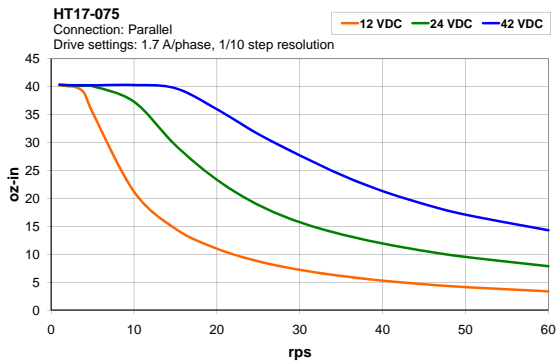

Sold & Serviced By:



Toll Free Phone (877) SERV098

Toll Free Fax (877) SERV099

www.electromate.com

sales@electromate.com

7080i -TORQUE CURVES

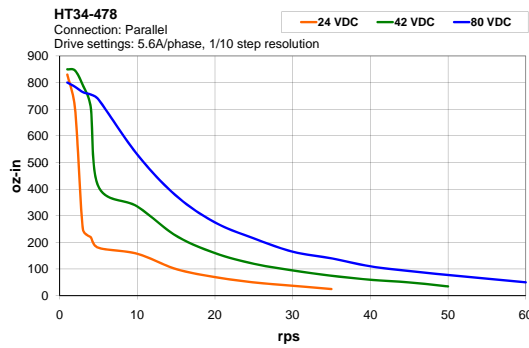
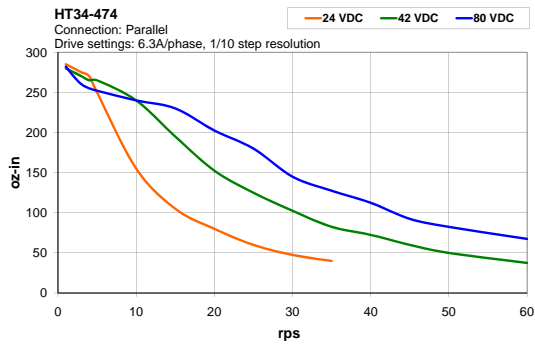
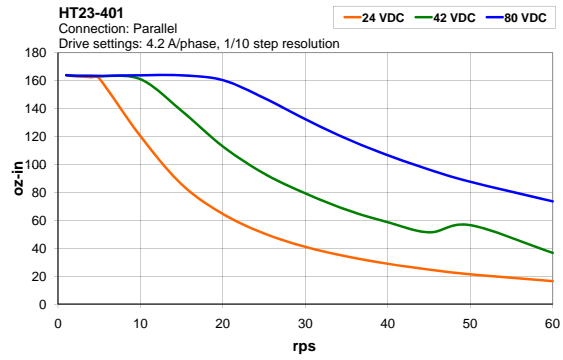
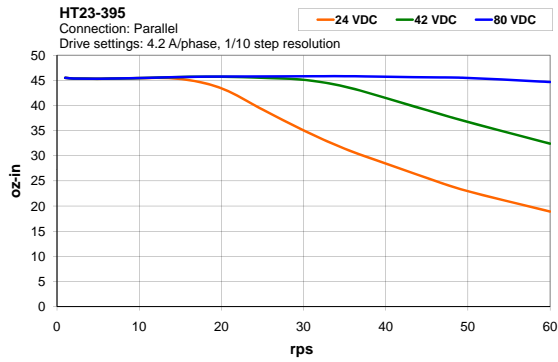

Sold & Serviced By:

 **ELECTROMATE**

Toll Free Phone (877) SERV098

Toll Free Fax (877) SERV099

www.electromate.com

sales@electromate.com

This page has been intentionally left blank

Sold & Serviced By:

 **ELECTROMATE**

Toll Free Phone (877) SERV098

Toll Free Fax (877) SERV099

www.electromate.com

sales@electromate.com

ST Series High Performance DC Input Step Drives



A High Performance Step Drive with 3 models for OEM Applications

ST Series stepper drives are aimed at OEMs who require the advanced features needed to get the best performance from their step motor system.

- ✓ Advanced Current Control
- ✓ Anti-Resonance
- ✓ Torque Ripple Smoothing
- ✓ Microstep Emulation

Specifications

POWER SUPPLY:

ST5 24-48 VDC
ST10 24-80 VDC

OUTPUT CURRENT:

ST5 0.1 - 5.0A Peak
ST10 0.1 - 10.0A Peak

PROTECTION:

- ↘ Over-Voltage
- ↘ Under voltage
- ↘ Over-Temp
- ↘ External Output Shorts

COMMUNICATIONS

- ↘ RS 232

Models

S

- Pulse & Direction
- CW/CCW Pulse
- A/B Quadrature
- Analog Velocity (Oscillator) mode
- Host commands (SCL compatible)
- SiNet Hub compatible

Q

- Q Programmer™ for programming
- Conditional Processing
- Math Functions
- Multi-tasking
- Register Manipulation
- Encoder Following
- "Generic" HMI compatibility

Si

- Si Programmer™ with built-in Configurator™
- Point-and-click indexing software
- Friendly GUI
- Excellent I/O and motion programming
- MMI-01 compatibility

Options

The ST 5/10 Si and Q models can be fitted with option boards to give the following functions:

- **ST-ENC** - Encoder Feedback Option.
- **ST-485** - RS485 Option.

Ordering information

ST5-Si-RE

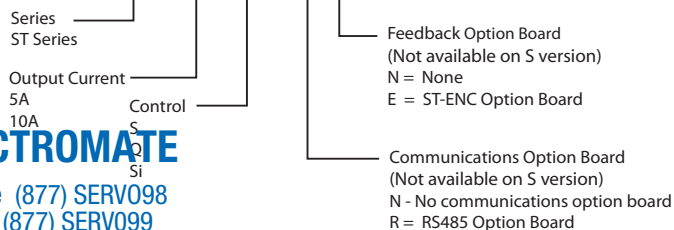

Sold & Serviced By:

 ELECTROMATE

Toll Free Phone (877) SERV098

Toll Free Fax (877) SERV099

www.electromate.com

sales@electromate.com



ST Series - Features

Anti-Resonance

Step motor systems have a natural tendency to resonate at certain speeds. The ST drives automatically calculate the system's natural frequency and apply damping to the control algorithm. This greatly improves midrange stability, allows higher speeds and greater torque utilization, and also improves settling times.

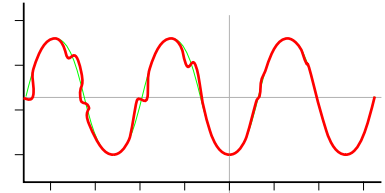

Delivers better motor performance and higher speeds

Microstep Emulation

With Microstep Emulation, low resolution systems can still provide smooth motion. The drive can take low resolution step pulses and create fine resolution motion.

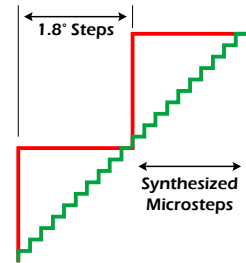

Delivers smoother motion in any application

Torque Ripple Smoothing

All step motors have an inherent low speed torque ripple that can affect the motion profile of the motor. By analyzing this torque ripple the system can apply a negative harmonic to negate this effect. This gives the motor much smoother motion at low speed.

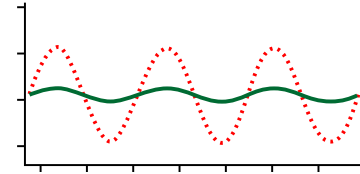

Delivers smoother motion at lower speeds

Command Signal Smoothing

Command Signal smoothing can soften the effect of immediate changes in velocity and direction, making the motion of the motor less jerky. An added advantage is that it can reduce the wear on mechanical components.



Delivers smoother system performance

Self Test & Auto Setup

At start-up the drive measures motor parameters, including the resistance and inductance, then uses this information to optimize system performance. It also compares this information to the last configuration and checks to see if the motor data has changed (this could indicate a fault or system change). The drive can also detect open and short circuits.

Inputs & Outputs

Sold & Serviced By:

ELECTROMATE
3 DIGITAL INPUTS
1 DIGITAL OUTPUT
1 ANALOG INPUT
Toll Free Phone (877) 551-0909
Toll Free Fax (877) 551-0909
www.electromate.com
sales@electromate.com

S

- 3 DIGITAL INPUTS
- 1 DIGITAL OUTPUT
- 1 ANALOG INPUT

Q

- 8 DIGITAL INPUTS
- 4 DIGITAL OUTPUTS
- 2 ANALOG INPUTS

Si

- 8 DIGITAL INPUTS
- 4 DIGITAL OUTPUTS

ST Series - Which version for your application?

Step & Direction

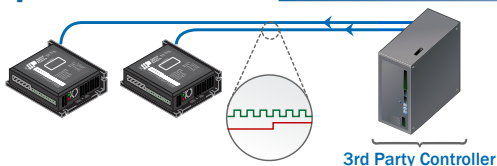

S

- STEP & DIRECTION
- CW & CCW PULSE
- MASTER ENCODER

Oscillator / Run-Stop



S

- SOFTWARE CONFIGURATION
- TWO SPEEDS
- VARY SPEED WITH ANALOG INPUT
- JOYSTICK COMPATIBLE

Host Control



S

- ACCEPTS COMMANDS FROM HOST PC OR PLC
- REAL TIME CONTROL

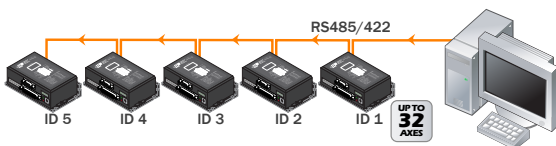

Q Si

- ACCEPTS COMMANDS FROM HOST PC OR PLC
- MULTI-AXIS CAPABLE
- REAL TIME CONTROL

Stand Alone Programmable

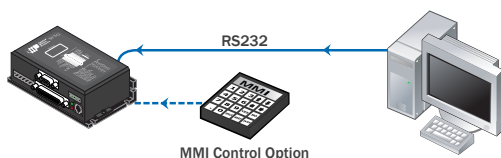

Si

- POINT & CLICK GRAPHICAL INTERFACE
- MMI OPTION
- DOWNLOAD, STORE & EXECUTE PROGRAMS

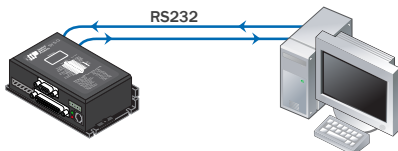

Q

- COMPREHENSIVE TEXT BASED LANGUAGE
- DOWNLOAD, STORE & EXECUTE PROGRAMS
- HIGH LEVEL FEATURES: MULTI TASKING, CONDITIONAL PROGRAMMING, & MATH FUNCTIONS
- HOST INTERFACE WHILE EXECUTING INTERNAL PROGRAMS

Multi axis Systems

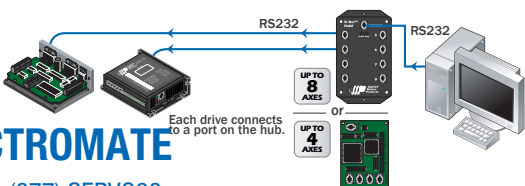

S Q Si

Use SiNet™ Hub Programmer software to develop your sequence of events, then download them to the hub for a stand-alone system or send serial commands to the drives from a PC, PLC, HMI, or other host controller.

Sold & Serviced By:

 **ELECTROMATE**

Toll Free Phone (877) SERV098

Toll Free Fax (877) SERV099

www.electromate.com

sales@electromate.com

ST5-S / ST10-S - PERFORMANCE OEM STEP DRIVE

QUICKLINK: ST

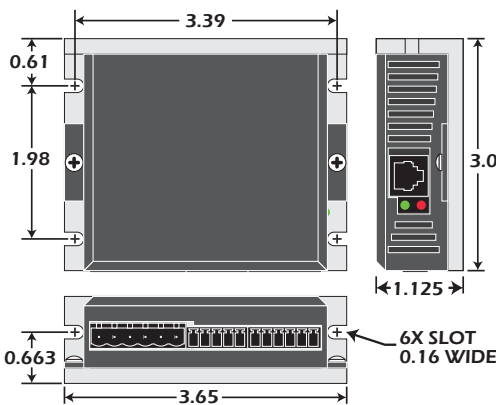

OUTPUT CURRENT

ST5-S 0.1-5 A
ST10-S 0.1-10 A

DC BUS VOLTAGE

ST5-S 24 - 48 VDC
ST10-S 24 - 80 VDC

WEIGHT

7.1 oz

SCL Compatible



FEATURES - also see pages 30-31

- Software setup
Using configurator™ software
- Microstepping
200 to 51200 steps /rev
- Pulse and direction
Pulse/direction, CW/CCW, A/B Quadrature
- Oscillator mode
Run/stop, direction and speed1/speed2 inputs.

SOFTWARE

- Configurator™
Easy to use graphical setup software
- SCL™ Setup Utility
Stream serial commands

INPUTS AND OUTPUTS

- 3 digital inputs
- 1 digital output
- 1 analog input

RECOMMENDED MOTORS

- HT17-068
- HT17-075
- HT23-394
- HT23-401
- HT34-485
- HT34-486
- HT34-487

This is a selection of the suitable motors for this drive. For more options visit the website.

Torque curves on page 34

ST5-Q / ST10-Q - PROGRAMMABLE STEP DRIVE

QUICKLINK: ST

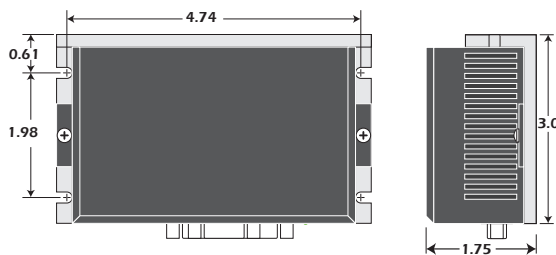

OUTPUT CURRENT

ST5-Q: 0.1-5 A
ST10-Q: 0.1-10 A

DC BUS VOLTAGE

ST5-Q 24 - 48 VDC
ST10-Q 24 - 80 VDC

WEIGHT

10.4 oz

SCL Compatible

Q Programmable



FEATURES - Also see pages 30-31

- Software setup
Using configurator™ software
- Microstepping
200 to 51200 steps /rev

INPUTS AND OUTPUTS

- 8 digital inputs
- 4 digital outputs
- 2 analog inputs

SOFTWARE

- Q Programmer™
- ST Configurator™
Easy to use graphical setup software
- SCL™ Setup Utility
Stream serial commands

RECOMMENDED MOTORS

- HT17-068
- HT17-075
- HT23-394
- HT23-401
- HT34-485
- HT34-486
- HT34-487

This is a selection of the suitable motors for this drive. For more options visit the website.

Torque curves on page 34

Sold & Serviced By:



Toll Free Phone (877) SERV098
Toll Free Fax (877) SERV099
www.electromate.com
sales@electromate.com

ST5-Si / ST10-Si - PROGRAMMABLE STEP DRIVE

QUICKLINK: ST

Si



OUTPUT CURRENT

ST5-Si **0.1-5 A**
ST10-Si **0.1-10 A**

DC BUS VOLTAGE

ST5-Si **24 - 48 VDC**
ST10-Si **24 - 80 VDC**

WEIGHT

10.4 oz

SCL Compatible

Si Programmable

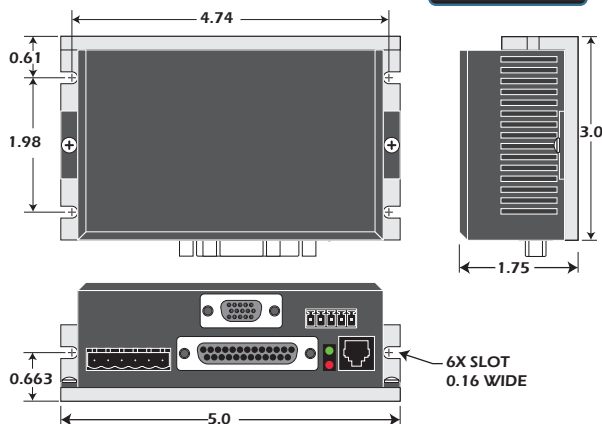

FEATURES - also see pages 30-31

- Microstepping
2000 to 51200 steps /rev
- Capable of all ST-S and ST-Q functions

INPUTS AND OUTPUTS

- 8 Digital inputs
- 4 Digital outputs

SOFTWARE

- Si Programmer™
Simple graphical point and click programming software
- SCL™ Setup Utility
Stream serial commands

RECOMMENDED MOTORS

- HT17-068
- HT17-075
- HT23-394
- HT23-401
- HT34-485
- HT34-486
- HT34-487

This is a selection of the suitable motors for this drive.
For more options visit the website.

Torque curves on page 34 

ST Options

QUICKLINK: ST

The ST 5/10 Si and Q models can be fitted with option boards to add the following functions:

- **ST-ENC** - Encoder Feedback Option.
- **ST-485** - RS485 Option.

ENCODER FEEDBACK

- The ST-ENC encoder feedback option board provides the following functionality:
- **Stall Detect:** The drive detects if the motor has stalled and triggers a fault.
- **Stall Prevention:** The drive automatically senses rotor lag and reduces motor speed to avoid stalling. This feature also includes "Position Maintenance" which is used when the motor is stopped.

RS485

- The ST-485 option board provides the following functionality:
- Multi drop serial communications: communicate to up to 32 drives via RS485, send commands, change parameters and interrogate the drive.



Sold & Serviced By:

 **ELECTROMATE**

Toll Free Phone (877) SERV098

Toll Free Fax (877) SERV099

www.electromate.com

sales@electromate.com



ST 5 -TORQUE CURVES

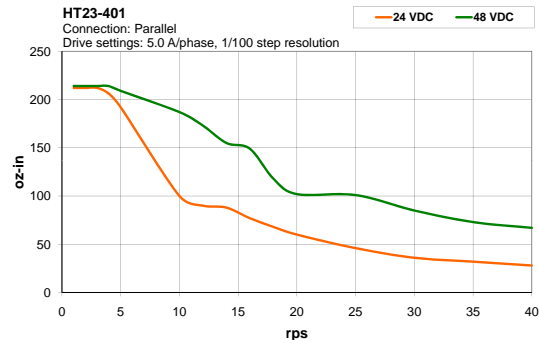
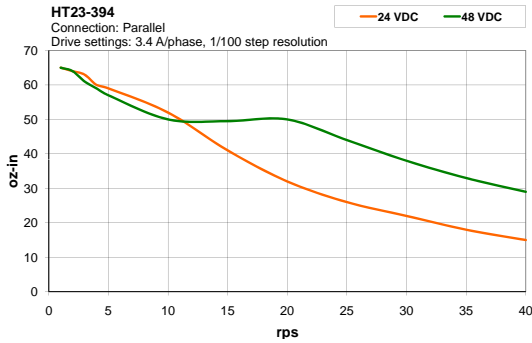
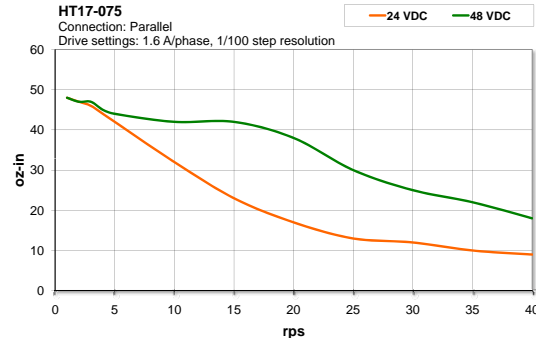
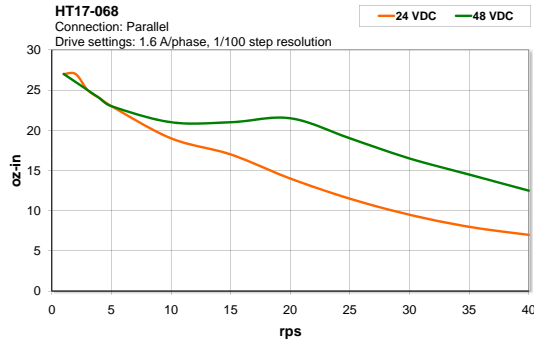

ST10 -TORQUE CURVES

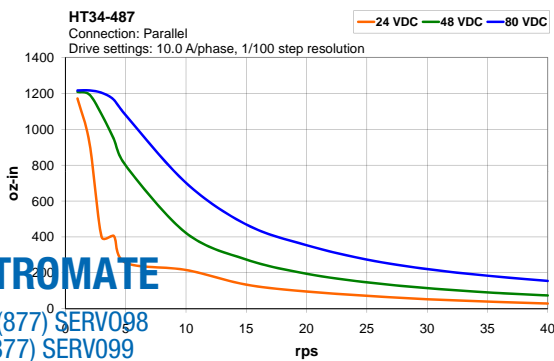
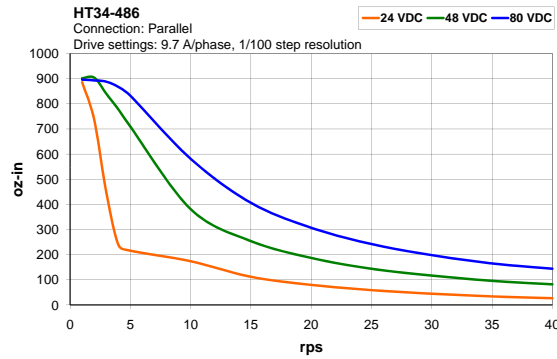
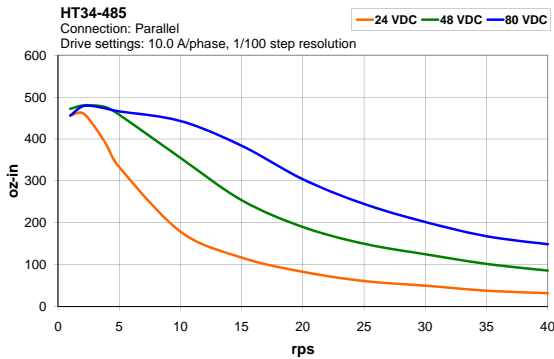

Sold & Serviced By:



Toll Free Phone (877) SERV098

Toll Free Fax (877) SERV099

www.electromate.com

sales@electromate.com

STAC6 Series Step Drives

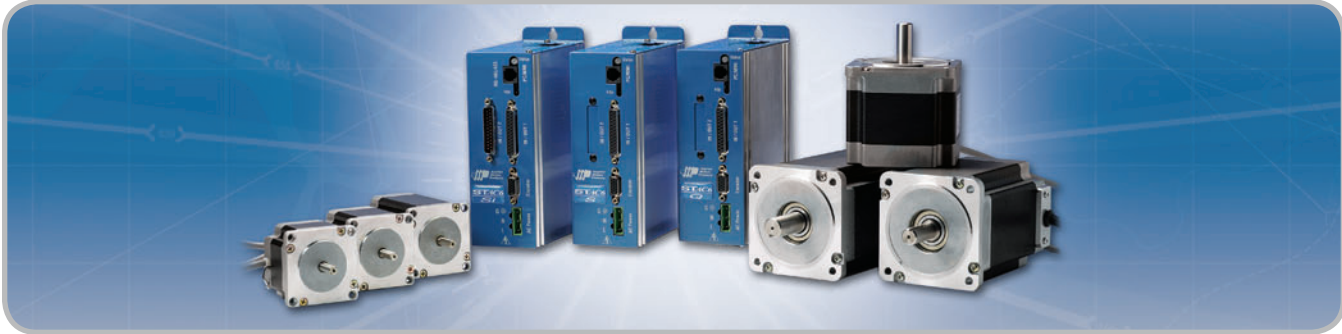

High Performance Step Drive with 3 Control Options for OEM Applications

The STAC6 is a top of the range stepper drive loaded with features to derive the highest performance from larger motors. Available for 110 and 220VAC input and in Programmable or External Control versions.

- ✓ **Advanced Current Control**
- ✓ **Anti-Resonance**
- ✓ **Torque Ripple Smoothing**
- ✓ **Microstep Emulation**
- ✓ **UL and CE**

Specifications

POWER SUPPLY:

STAC6 94-135 VAC
STAC6-220 94-265 VAC

PROTECTION:

- OVER-VOLTAGE
- UNDER VOLTAGE
- OVER-TEMP
- EXTERNAL OUTPUT SHORTS
- REGENERATION

OUTPUT CURRENT:

STAC6 0.5 - 6.0A Peak
STAC6-220 0.5 - 3.2A Peak

Encoder Feedback

With the addition of an encoder on the motor the STAC6 can provide additional functions:

STALL DETECT:

The drive detects if the motor has stalled and triggers a fault.

STALL PREVENTION:

The drive automatically senses rotor lag and reduces motor speed to avoid stalling. This feature includes "Position Maintenance" which is used when the motor is stopped.

Models

S

- Pulse & Direction
- CW/CCW Pulse
- A/B Quadrature
- Analog Velocity (Oscillator) mode
- Host commands (SCL compatible)
- SiNet Hub compatible
- Configurator software for setup

Q

- Q Programmer™ for programming
- Conditional Processing
- Math Functions
- Multi-tasking
- Register Manipulation
- Encoder Following
- "Generic" HMI compatibility

Si

- Si Programmer™ with built-in Configurator™
- Point-and-click indexing software
- Friendly GUI
- Excellent I/O and motion programming
- MMI-01 compatibility

Sold & Serviced By:

 **ELECTROMATE**

Toll Free Phone (877) SERV098

Toll Free Fax (877) SERV099

www.electromate.com

sales@electromate.com

STAC6 Series - Features

Anti-Resonance

Step motor systems have a natural tendency to resonate at certain speeds. The ST drives automatically calculate the system's natural frequency and apply damping to the control algorithm. This greatly improves midrange stability, allows higher speeds and greater torque utilization, and also improves settling times.

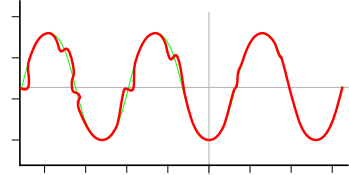

Delivers better motor performance and higher speeds

Microstep Emulation

With Microstep Emulation, low resolution systems can still provide smooth motion. The drive can take low-resolution step pulses and create fine resolution motion.

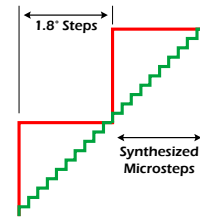

Delivers smoother motion in any application

Torque Ripple Smoothing

All step motors have an inherent low speed torque ripple that can affect the motion of the motor. By analyzing this torque ripple the system can apply a negative harmonic to negate this effect, which gives the motor much smoother motion at low speed.

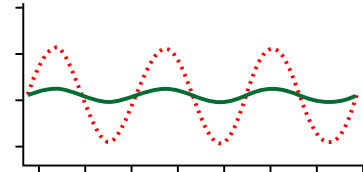

Delivers smoother motion at lower speeds

Command Signal Smoothing

Command Signal smoothing can soften the effect of immediate changes in velocity and direction, making the motion of the motor less jerky. An added advantage is that it can reduce the wear on mechanical components.

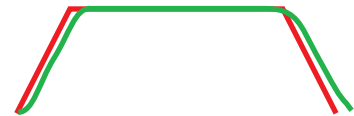

Delivers smoother system performance

Self Test & Auto Setup

At start-up the drive measures motor parameters, including the resistance and inductance, then uses this information to optimize the system performance. It also compares this information to the last configuration and checks to see if the motor data has changed (this could indicate a fault or system change). The drive can also detect open and short circuits.

Inputs & Outputs

S

7 digital inputs
3 digital outputs
2 analog inputs

Expanded I/O - (SE version)

15 digital inputs
7 digital outputs
2 analog inputs

Q

7 digital inputs
3 digital outputs
2 analog inputs

Expanded I/O - (QE version)

15 digital inputs
7 digital outputs
2 analog inputs

Si

15 digital inputs
7 digital outputs

Sold & Serviced By:

 **ELECTROMATE**

Toll Free Phone (877) SERV098
Toll Free Fax (877) SERV099

www.electromate.com

sales@electromate.com

STAC6 Series - Which version for your application

Step & Direction

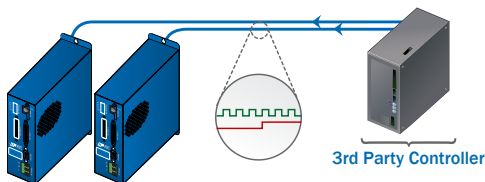

S

- STEP & DIRECTION
- CW & CCW PULSE
- A/B QUADRATURE

Oscillator / Run-Stop

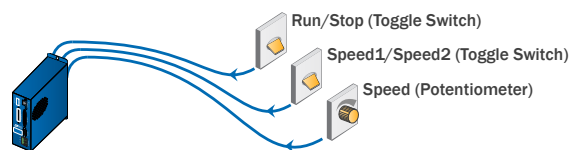

S

- SOFTWARE CONFIGURATION
- TWO SPEEDS
- VARY SPEED WITH ANALOG INPUT
- JOYSTICK COMPATIBLE

Host Control

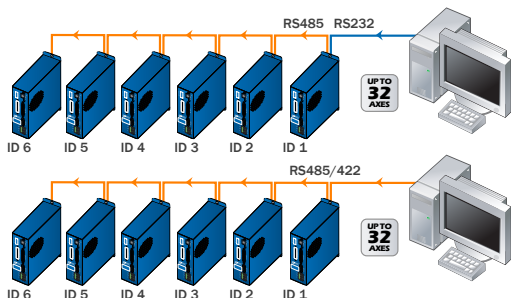

S Q Si

- ACCEPTS HOST COMMANDS FROM PC OR PLC
- MULTI-AXIS CAPABLE
- STREAM SERIAL COMMANDS

Stand Alone Programmable

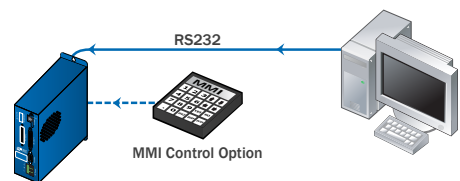

Si

- POINT & CLICK GRAPHICAL INTERFACE
- DOWNLOAD, STORE & EXECUTE PROGRAMS
- MMI OPTION

Q

- COMPREHENSIVE TEXT BASED LANGUAGE
- DOWNLOAD, STORE & EXECUTE PROGRAMS
- HIGH LEVEL FEATURES: MULTI TASKING, CONDITIONAL PROGRAMMING, MATH FUNCTIONS
- HOST INTERFACE WHILE EXECUTING INTERNAL PROGRAMS

Multi axis Systems

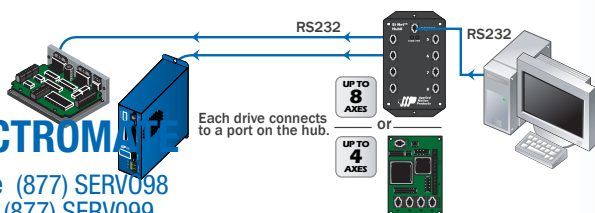

S Q Si

Use SiNet™ Hub Programmer software to develop your sequence of events, then download them to the hub for a stand-alone system **or** send serial commands to the drives from a PC, PLC, HMI, or other host controller.

Sold & Serviced By:

 **ELECTROMATE**

Toll Free Phone (877) SERV098

Toll Free Fax (877) SERV099

www.electromate.com

sales@electromate.com

STAC6 - S - AC INPUT PERFORMANCE STEP DRIVE

QUICKLINK: STAC6



Base Version with
Step/Direction Input
or Host Control

SCL Compatible

OUTPUT CURRENT

STAC6 -S: 0.5 - 6.0 A
STAC6-220-S: 0.5 - 3.2 A

POWER SUPPLY

STAC6 -Si: 94 - 135 VAC single phase
STAC6-220-Si: 94 - 265 VAC single phase

WEIGHT

2 lbs

FEATURES (also see pages 36-37)

- Software setup using STAC6 Configurator™ software
- Microstepping
200 to 51200 steps /rev
- Pulse and direction
Pulse/direction, CW/CCW, A/B Quadrature
- Oscillator
- Idle Current Reduction

INPUTS AND OUTPUTS

- 7 DIGITAL INPUTS
- 3 DIGITAL OUTPUTS
- 2 ANALOG INPUTS

EXPANDED I/O - (SE VERSION)

- 15 DIGITAL INPUTS
- 7 DIGITAL OUTPUTS
- 2 ANALOG INPUTS

SOFTWARE

- STAC6 Configurator™
Easy to use graphical setup software
- SCL™ Setup Utility
Stream Serial Commands

RECOMMENDED MOTORS

- REFER TO PAGES 40-41

STAC6 - Q - AC INPUT PERFORMANCE STEP DRIVE

QUICKLINK: STAC6



Step Drive / Indexer
Programmable with Q
programmer™ software

➤ For more information on Q
Programmer™ Software see page 9

Q Programmable

SCL Compatible

OUTPUT CURRENT

STAC6 -Q: 0.5 - 6.0 A
STAC6-220-Q: 0.5 - 3.2 A

POWER SUPPLY

STAC6 -Q: 94 - 135 VAC single phase
STAC6-220-Q: 94 - 265 VAC single phase

WEIGHT

2 lbs

FEATURES (also see pages 36-37)

- Software setup using configurator software
- Microstepping
200 to 51200 steps /rev
- Idle Current Reduction

INPUTS AND OUTPUTS

- 7 DIGITAL INPUTS
- 3 DIGITAL OUTPUTS
- 2 ANALOG INPUTS

EXPANDED I/O - (QE VERSION)

- 15 DIGITAL INPUTS
- 7 DIGITAL OUTPUTS
- 2 ANALOG INPUTS

SOFTWARE

- STAC6 Configurator™
Easy to use graphical setup software
- Q Programmer™
- SCL™ Setup Utility
Stream Serial Commands

RECOMMENDED MOTORS

- REFER TO PAGES 40-41

Sold & Serviced By:

 **ELECTROMATE**

Toll Free Phone (877) SERV098

Toll Free Fax (877) SERV099

www.electromate.com

sales@electromate.com

STAC6 - Si -AC INPUT PERFORMANCE STEP DRIVE

QUICKLINK: STAC6



Step Drive / Indexer programmable with Si "Simple Indexer software"

➤ For more information on Si Software see page 8

SCL Compatible

Si Programmable

OUTPUT CURRENT

STAC6 -Si: 0.5 - 6.0 A

STAC6220-Si: 0.5 - 3.2 A

POWER SUPPLY

STAC6 -Si: 94 - 135 VAC single phase

STAC6-220-Si: 94 - 265 VAC single phase

WEIGHT

2 lbs

FEATURES (also see pages 36-37)

- Software setup using STAC6 configurator™ software
- Microstepping
2000 to 51200 steps /rev
- Idle Current Reduction

INPUTS AND OUTPUTS

- 15 DIGITAL INPUTS
- 7 DIGITAL OUTPUTS

SOFTWARE

- Si Programmer
Simple graphical point and click programming software
- SCL™ Setup Utility
Stream Serial Commands

RECOMMENDED MOTORS

- REFER TO PAGES 40-41

STAC6- Detailed Specifications

POWER AMPLIFIER SECTION

- IDLE CURRENT REDUCTION
Reduction to any integer percent of full-current after delay selectable in milliseconds.
- MOTOR REGENERATION
Built in regeneration circuit - 25 watts max.

CONTROLLER SECTION

- STEP AND DIRECTION INPUTS
Optically Isolated: 5-12 Volt. Minimum pulse width = 200 ns.
Maximum pulse frequency = 2 MHz
- SPEED RANGE
Depends upon selected resolution. Amplifier is suitable for speeds up to 100 rps
- RESOLUTION
Software selectable from 200-to-51200 steps/rev in increments of 2 steps/rev
- ENCODER OPTION
Employs encoder to provide stall detect and perform stall prevention and position maintenance.
- SERIAL INTERFACE
RS-232, RS-422 and RS-485
- ENCODER
Differential line receivers suitable for 500 KHz or greater

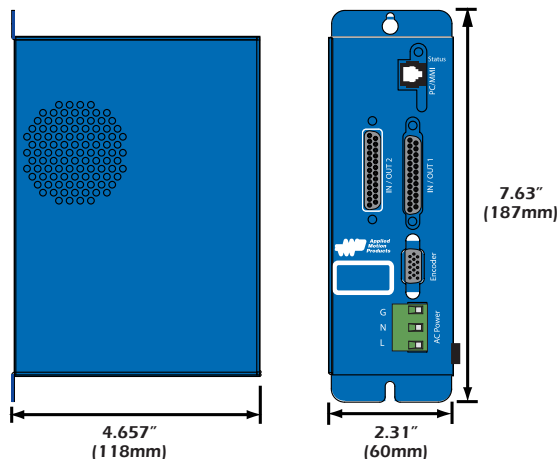

- AGENCY APPROVALS
UL Recognized Component (110 V version only)
CE - EN 61800-3:2004
EN 61800-5-1 :2003

Sold & Serviced By: AMBIENT TEMPERATURE



Toll Free Phone (877) SERV098

Toll Free Fax (877) SERV099

www.electromate.com

sales@electromate.com

STAC6 110v NEMA 23 Motors

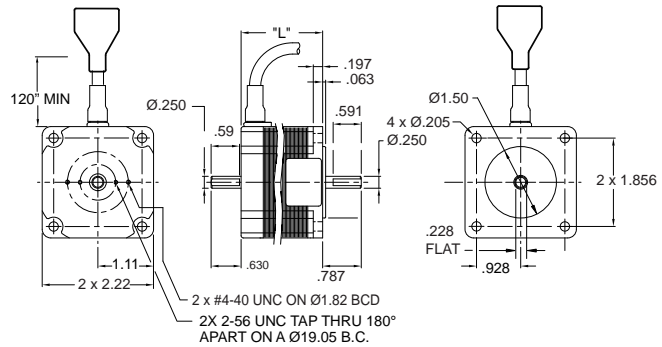
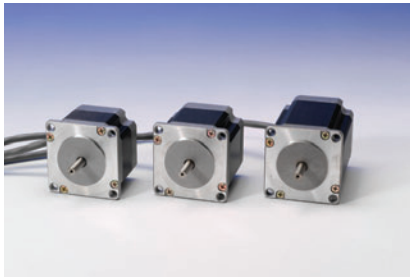

	HOLDING TORQUE OZ-IN	RATED CURRENT A	RESISTANCE OHMS*	INDUCTANCE MH	ROTOR INERTIA OZ-IN ²	LENGTH "L"	DIA "D"
HT23-548	60	1.5	3.5	5.6	0.66	1.7" (43.8mm)	0.25" (6.35mm)
HT23-549	118	1.5	4.3	12.8	1.64	2.16" (54.8mm)	0.25" (6.35mm)
HT23-550	180	1.8	5.2	15.2	2.62	3.05" (77.47mm)	0.25" (6.35mm)

* value includes cable

Notes -

- 1) Drawing shown with optional rear shaft.
- 2) Encoder holes only on dual shaft version.
- 3) The data shown in this table represents the specifications for this motor when wired for the STAC6
- 4) These motors fitted with 10ft cable and connector
- 5) Part numbers listed are for single shaft. To order double shaft add "D" to the part number. Example: HT23-550D.

STAC6 110v NEMA 34 Motors

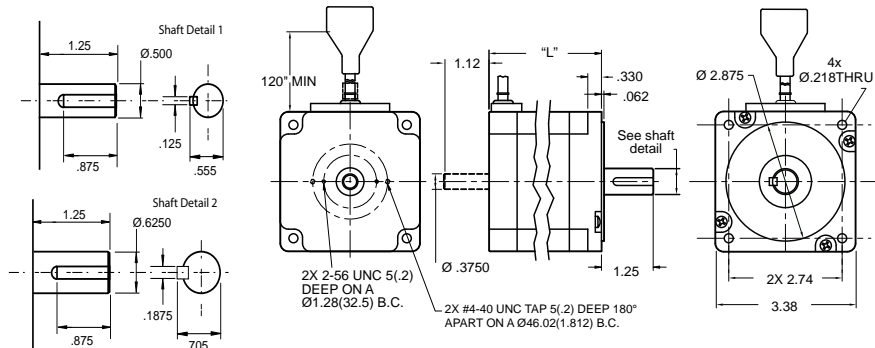

	HOLDING TORQUE OZ-IN	RATED CURRENT A	RESISTANCE OHMS*	INDUCTANCE MH	ROTOR INERTIA OZ-IN ²	LENGTH "L"	DIA "D"
HT34-488	555	5.1	1.4	5.2	8.7	3.11" (79mm)	0.5" (12.7mm)
HT34-489	1100	5.1	1.7	10.5	17.5	4.63" (117.6mm)	0.5" (12.7mm)
HT34-490	1694	5.8	1.7	11	26.2	6.14" (155.9mm)	0.625" (15.875)

* value includes cable

Notes -

- 1) Drawing shown with optional rear shaft.
- 2) Encoder holes only on dual shaft version.
- 3) The data shown in this table represents the specifications for this motor when wired for the STAC6
- 4) These motors fitted with 10ft cable and connector
- 5) Part numbers listed are for single shaft. To order double shaft add "D" to the part number. Example: HT34-489D.

Sold & Serviced By:



Toll Free Phone (877) SERV099
 Toll Free Fax (877) SERV099
www.electromate.com
sales@electromate.com

STAC6-220 NEMA 23 Motors

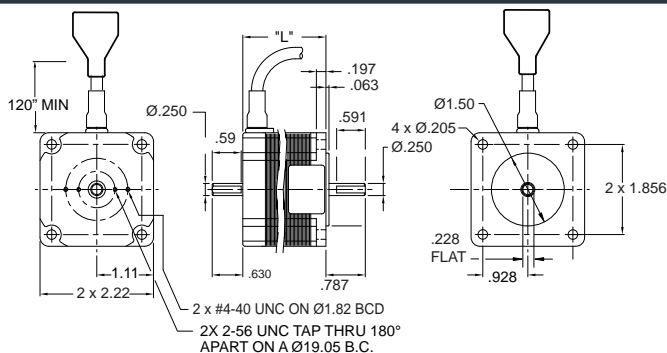
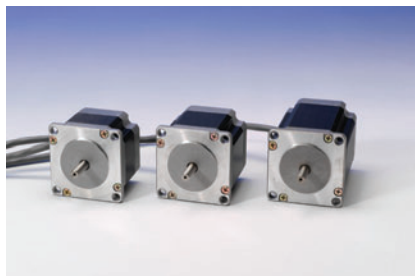

	HOLDING TORQUE OZ-IN	RATED CURRENT A	RESISTANCE OHMS*	INDUCTANCE MH	ROTOR INERTIA OZ-IN ²	LENGTH "L"	DIA "D"
HT23-552	60	0.75	22.4	22.4	0.66	1.7" (43.8mm)	0.25" (6.35mm)
HT23-553	118	0.75	51.2	51.2	1.64	2.16" (54.8mm)	0.25" (6.35mm)
HT23-554	180	0.9	60.8	60.8	2.62	3.05" (77.47mm)	0.25" (6.35mm)

* value includes cable

Notes -

- 1) Drawing shown with optional rear shaft.
- 2) Encoder holes only on dual shaft version.
- 3) The data shown in this table represents the specifications for this motor when wired for the STAC6-220
- 4) These motors fitted with 10ft cable and connector
- 5) Part numbers listed are for single shaft. To order double shaft add "D" to the part number. Example: HT34-554D.

STAC6-220 NEMA 34 Motors

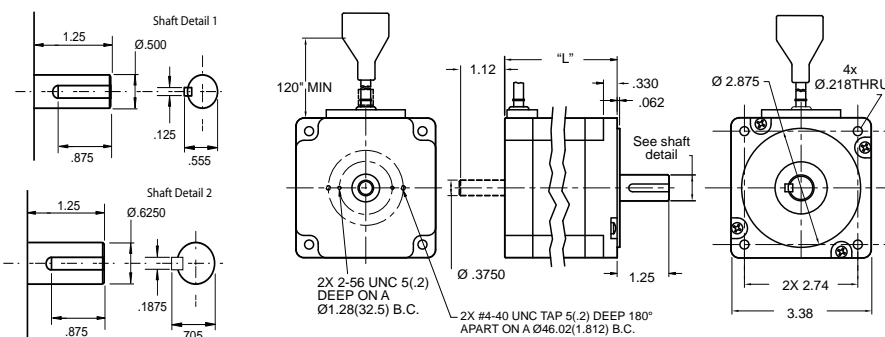

	HOLDING TORQUE OZ-IN	RATED CURRENT A	RESISTANCE OHMS*	INDUCTANCE MH	ROTOR INERTIA OZ-IN ²	LENGTH "L"	DIA "D"
HT34-495	555	2.55	4.3	26	8.7	3.11" (79mm)	0.5" (12.7mm)
HT34-496	1100	2.55	5.58	42	17.5	4.63" (117.6mm)	0.5" (12.7mm)
HT34-497	1694	3.2	5.58	45	26.2	6.14" (155.9mm)	0.625" (15.875)

* value includes cable

Notes -

- 1) Drawing shown with optional rear shaft.
- 2) Encoder holes only on dual shaft version.
- 3) The data shown in this table represents the specifications for this motor when wired for the STAC6-220
- 4) These motors fitted with 10ft cable and connector
- 5) Part numbers listed are for single shaft. To order double shaft add "D" to the part number. Example: HT34-497D.

Sold & Serviced By:



Toll Free Phone: (877) SERV098
 Toll Free Fax: (877) SERV099
www.electromate.com
sales@electromate.com



STAC6 110 - NEMA 23 - TORQUE CURVES

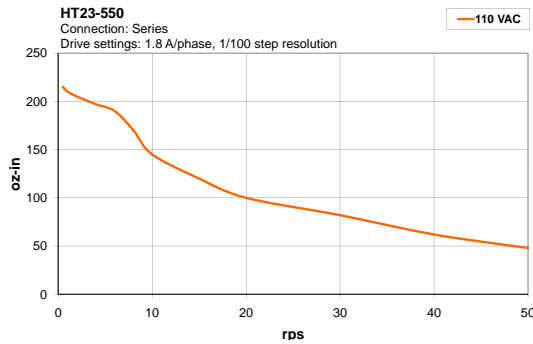
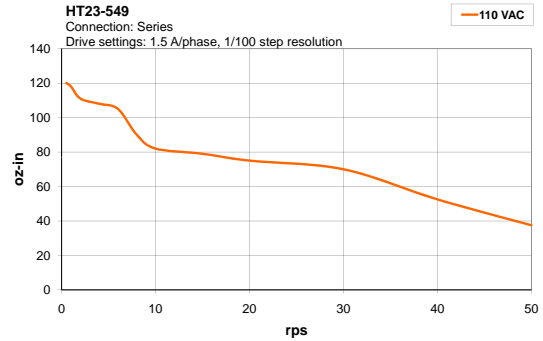
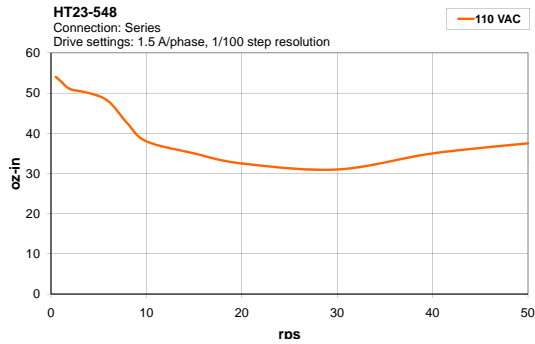

STAC6 110 NEMA 34 - TORQUE CURVES

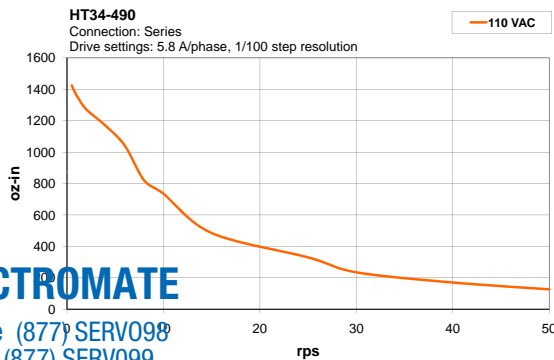
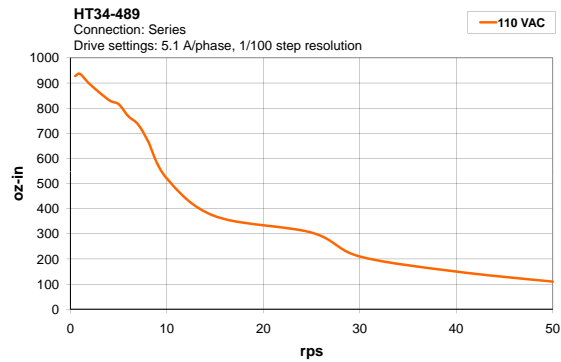
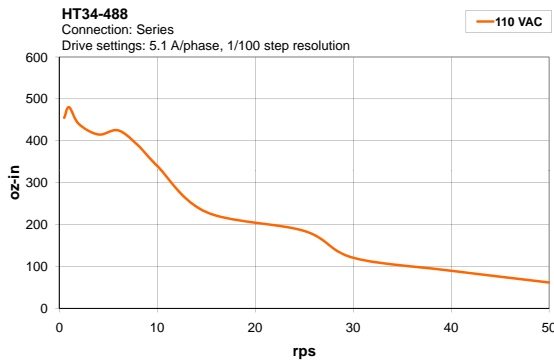

Sold & Serviced By:



Toll Free Phone (877) SERV098

Toll Free Fax (877) SERV099

www.electromate.com

sales@electromate.com

STAC6 220 - NEMA 23 - TORQUE CURVES

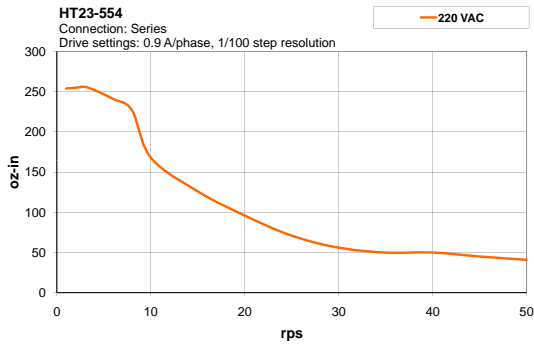
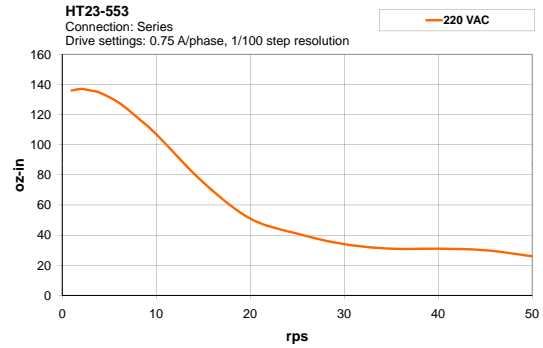
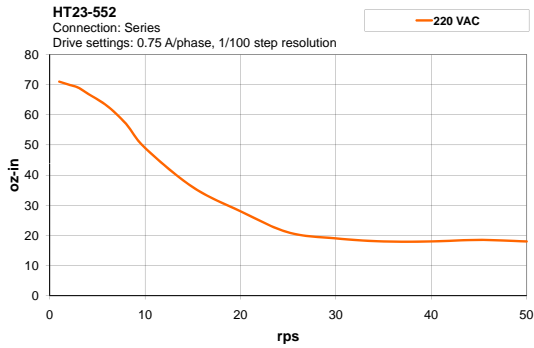

STAC6 220 NEMA 34 - TORQUE CURVES

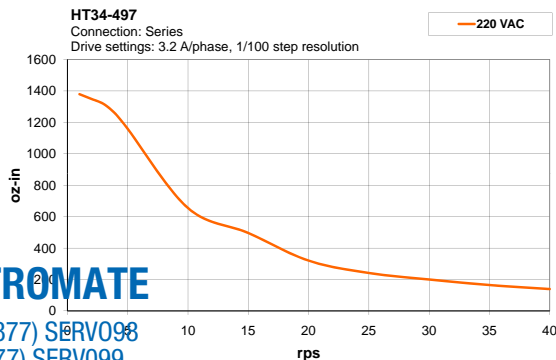
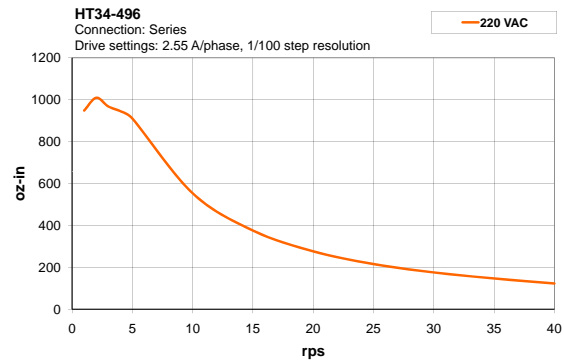
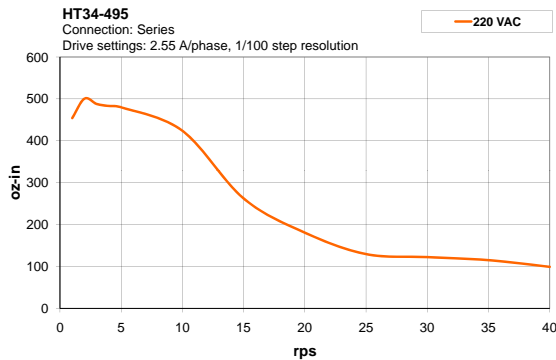

Sold & Serviced By:



Toll Free Phone (877) SERV098
Toll Free Fax (877) SERV099
www.electromate.com
sales@electromate.com

This page has been intentionally left blank

Sold & Serviced By:

 **ELECTROMATE**

Toll Free Phone (877) SERV098

Toll Free Fax (877) SERV099

www.electromate.com

sales@electromate.com

AC Input Drives with Controls

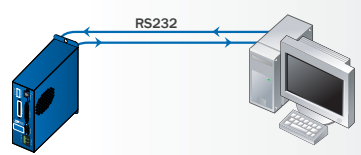
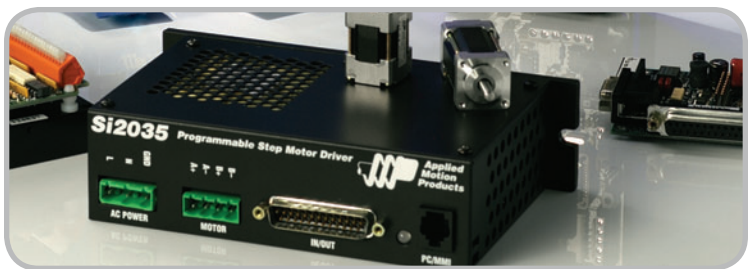
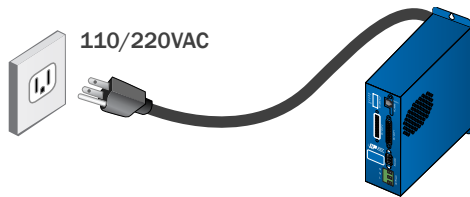

SCL™ (HOST CONTROL)

Intelligent drives can be used as part of a host controlled system. This means the drive accepts Serial Commands from a host PC or PLC.

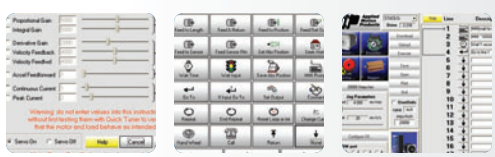

SI PROGRAMMER™

Intended for use in stand-alone applications, Si Programmer™ provides a friendly, point-and-click, graphical interface that doesn't require any previous programming experience.

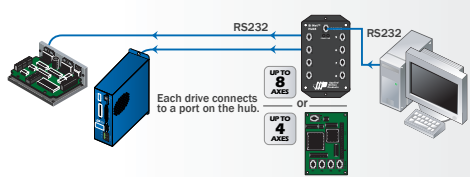

MULTI-AXIS SYSTEMS

Use SiNet™ Hub Programmer software to develop your sequence of events, then download them to the Hub for a stand-alone system **or** send serial commands to the drives from a PC, PLC, HMI, or other host controller.

Sold & Serviced By:

 **ELECTROMATE**

Toll Free Phone (877) SERV098

Toll Free Fax (877) SERV099

www.electromate.com

sales@electromate.com

Si2035 - PACKAGED PROGRAMMABLE DRIVE WITH INTEGRATED POWER SUPPLY

QUICKLINK: si2035



Si Programmable

SCL Compatible

Step Drive / Indexer Programmable with Si "Simple Indexer software"

➤ For more information on Si software see page 8

FEATURES

- Microstepping - 2000 to 50800 steps/rev
- 110/220VAC Input - SWITCH SELECTABLE
- Idle Current 0%, 25%, 50%, 100%
- Eight optically isolated inputs 12 - 24 VDC. Can be configured for sinking (NPN) or sourcing (PNP) signals.
- Four optically isolated outputs 30 V max, 100mA max

SPECIFICATIONS

Output Current: **2.0 A max**
 DC Bus Voltage: **35 VDC**
 AC Input Voltage: **110/220VAC single phase**

WEIGHT

3 lbs

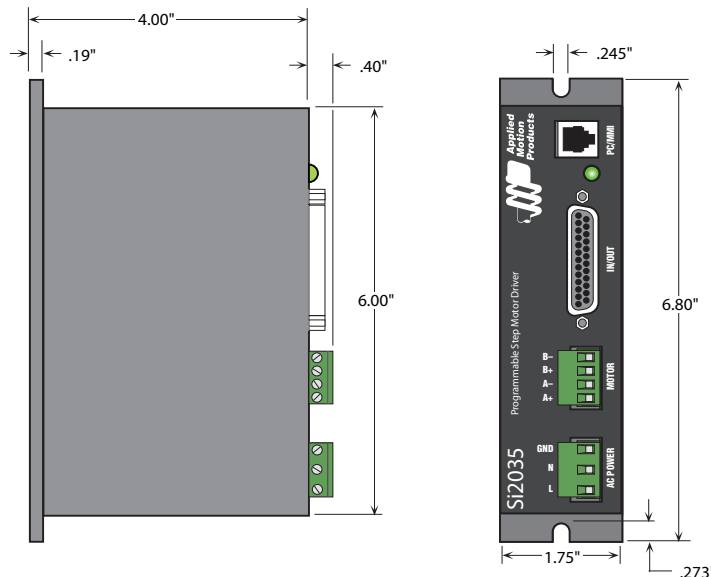

SOFTWARE

- Si Programmer™ Download, store and execute programs.
- SCL™ Setup Utility Stream serial commands.

Software and programming cables supplied. Go to page 10 for more info...

INCLUDES

- Mating Connectors, Software & Programming Cable

RECOMMENDED MOTORS

- HT17-068
- HT17-071
- HT17-075
- HT23-394

This is a selection of the suitable motors for this drive. For more options visit the website.

Visit: www.applied-motion.com for torque curves and other tech data.

Sold & Serviced By:

 **ELECTROMATE**

Toll Free Phone (877) SERV098
 Toll Free Fax (877) SERV099
www.electromate.com
sales@electromate.com

Si3540 - PROGRAMMABLE DRIVE WITH INTEGRATED POWER SUPPLY

QUICKLINK: si3540



Si Programmable

SCL Compatible

Step Drive / Indexer Programmable with Si "Simple Indexer software"

For more information on Si Software see page 8

FEATURES

- Microstepping
2000 to 50800 steps/rev
- 110/220VAC Input
SWITCH SELECTABLE
- Idle Current
0%, 25%, 50%, 100%
- Eight optically isolated inputs
12 - 24 VDC. Can be configured for sinking (NPN) or sourcing (PNP) signals.
- Three optically isolated outputs
30 V max, 100mA maximum
- One optically isolated output 5 VDC
Dedicated to fault out

SPECIFICATIONS

- Output Current: **3.5 A**
- DC Bus Voltage: **40 VDC**
- AC Input Voltage: **110/220VAC single phase**

WEIGHT

4 lbs

SOFTWARE

- Si Programmer™
Download, store and execute programs.
- SCL™ Setup Utility
Stream serial commands.

Software and programming cables supplied. Go to page 8 for more info...

INCLUDES

- Mating Connectors, Software & Programming Cable

RECOMMENDED MOTORS

- HT17-075
 - HT23-394
 - HT23-397
 - HT23-400
- This is a selection of the suitable motors for this drive. For more options visit the website.

Visit: www.applied-motion.com for torque curves and other tech data.

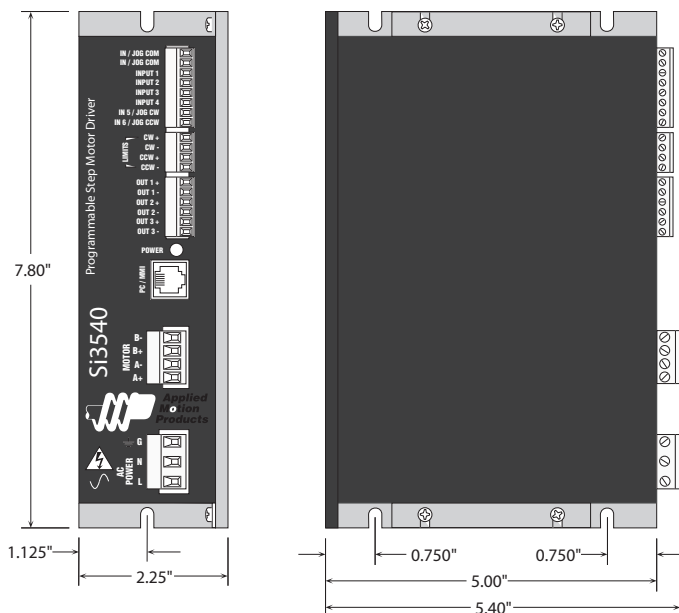

Sold & Serviced By:



Toll Free Phone (877) SERV098
Toll Free Fax (877) SERV099
www.electromate.com
sales@electromate.com

Si5580 - PROGRAMMABLE DRIVE WITH INTEGRATED POWER SUPPLY

QUICKLINK: SI5580



Si Programmable

SCL Compatible

Step Drive / Indexer Programmable with Si "Simple Indexer" software

For more information on Si Software see page 8

FEATURES

- Microstepping
2000 to 50800 steps/rev
- 110/220VAC Input
Switch Selectable
- Idle Current
0%, 25%, 50%, 100%
- Eight optically isolated inputs 12 - 24 VDC.
Can be configured for sinking (NPN) or sourcing (PNP) signals.
- Three optically isolated outputs
30 V max, 100mA maximum
- "Fault" output.
Optically Isolated

SPECIFICATIONS

Output Current: **5.5 A**
 DC Bus Voltage: **80 VDC**
 AC Input Voltage: **110/220VAC single phase**

WEIGHT

7.8 lbs

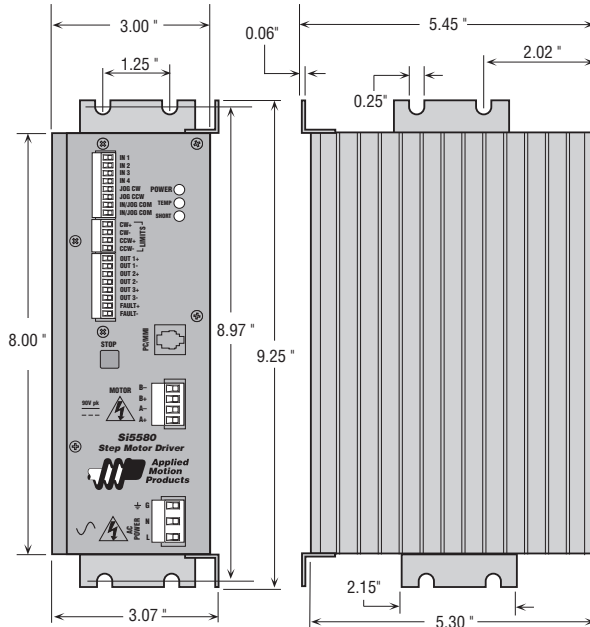

SOFTWARE

- Si Programmer™
Download, store and execute programs.
- SCL™ Setup Utility
Stream serial commands.

Software and programming cables supplied. Go to page 10 for more info...

INCLUDES

- Mating Connectors
- Software & Programming Cable

RECOMMENDED MOTORS

- HT23-398
- HT23-400
- HT34-474
- HT34-478

This is a selection of the suitable motors for this drive. For more options visit the website.

Visit: www.applied-motion.com for torque curves and other tech data.

Sold & Serviced By:



Toll Free Phone (877) SERV098
 Toll Free Fax (877) SERV099
www.electromate.com
sales@electromate.com

Torque curves on page 50

Si2035 - TORQUE CURVES

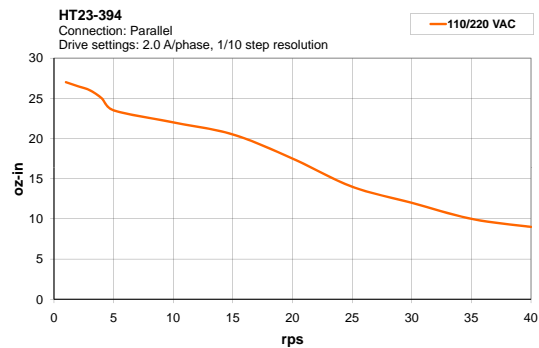
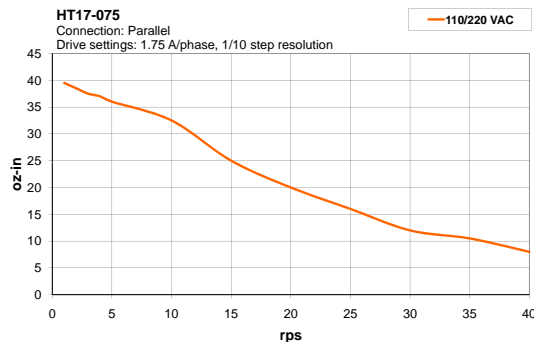
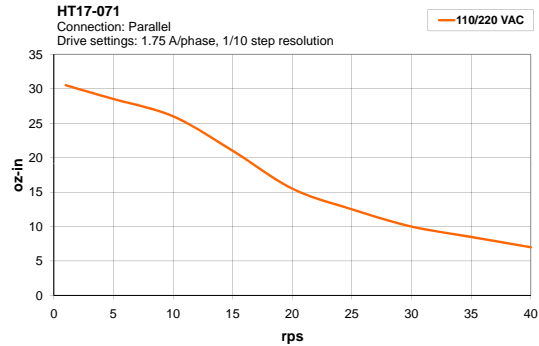
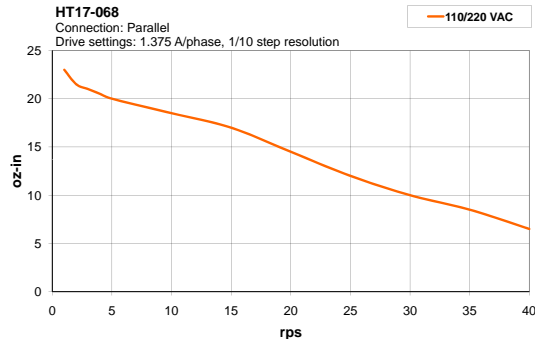

Si3540 - TORQUE CURVES

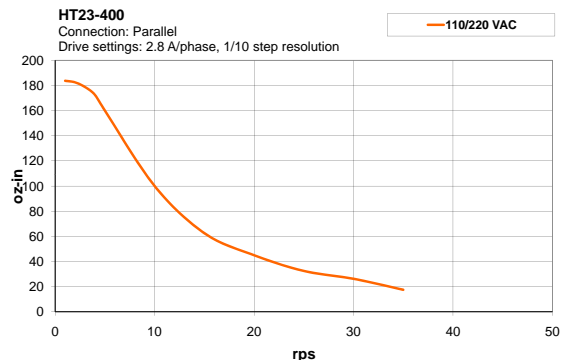
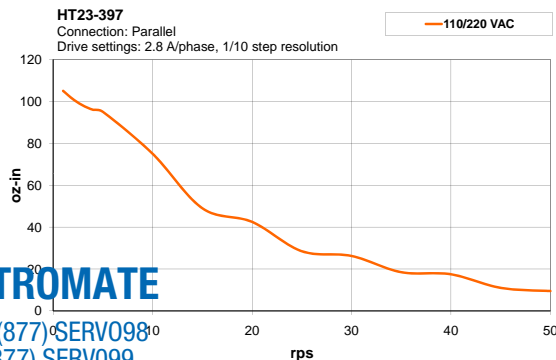
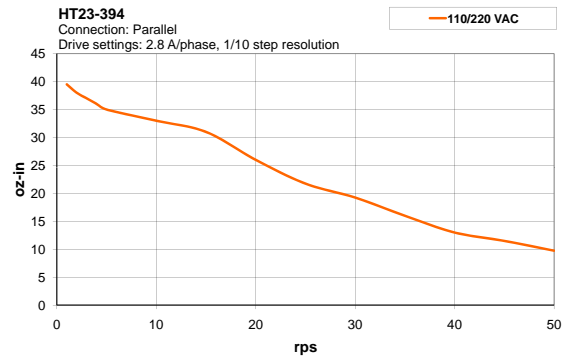
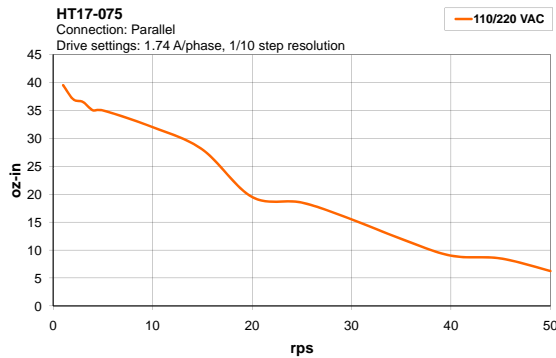

Sold & Serviced By:



Toll Free Phone (877) SERV098
Toll Free Fax (877) SERV099
www.electromate.com
sales@electromate.com



Si5580 - TORQUE CURVES

HT23-398

Connection: Parallel
Drive settings: 4.3A/phase, 1/10 step resolution

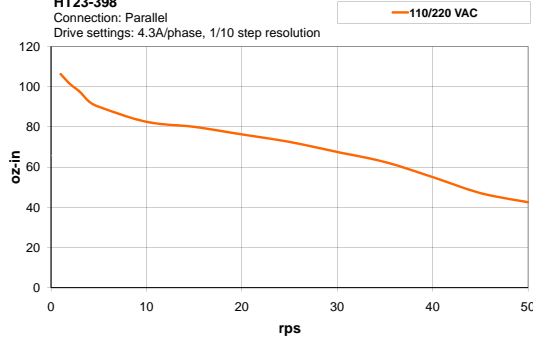

HT23-401

Connection: Parallel
Drive settings: 4.3A/phase, Full step resolution

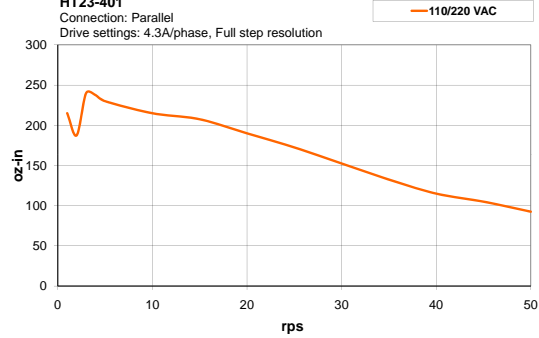

HT34-474

Connection: Parallel
Drive settings: 5.5A/phase, 1/10 step resolution

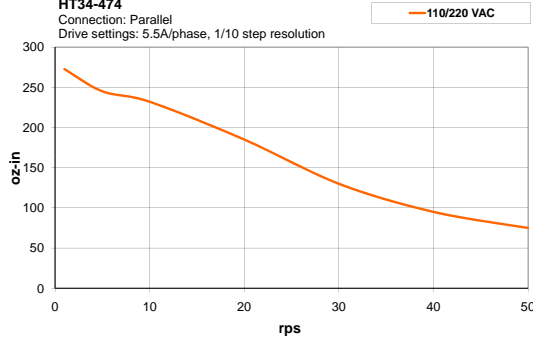

HT34-478

Connection: Parallel
Drive settings: 5.5A/phase, 1/10 step resolution

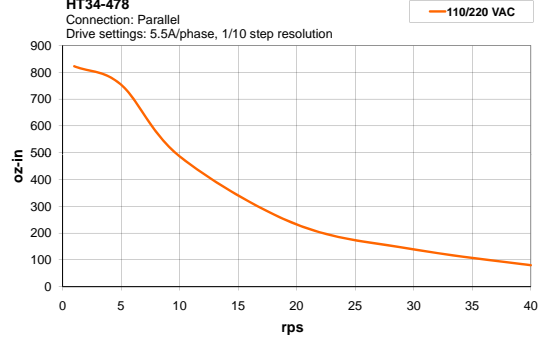

Sold & Serviced By:



Toll Free Phone (877) SERV098

Toll Free Fax (877) SERV099

www.electromate.com

sales@electromate.com

AC Input Step Drives

For single axis application, drives with an integrated power supply are a cost effective option.

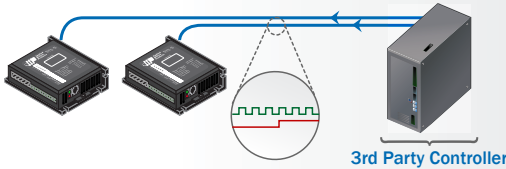
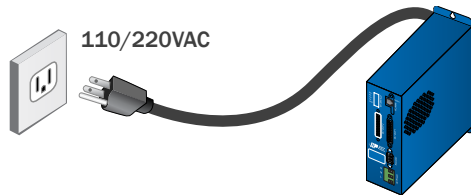

STEP & DIRECTION

The Controller sends Pulse & Direction signals to each drive. The functionality and number of axes controlled will depend on the controller.



OSCILLATOR MODE

An internal oscillator develops a speed signal, allowing the drive to run at a pre-configured velocity. In some cases the velocity can be varied by an analog control signal.

Sold & Serviced By:

ELECTROMATE

Toll Free Phone (877) SERV098

Toll Free Fax (877) SERV099

www.electromate.com

sales@electromate.com

PDO2035 - PULSE AND DIRECTION DRIVE WITH DIGITAL OSCILLATOR

QUICKLINK: PD02035



SPECIFICATIONS

Output Current: **2.0 A**
 DC Bus Voltage: **35 VDC**
 AC Input Voltage: **110-220 single phase**

WEIGHT
 3 lbs

FEATURES

- ↘ AC input 110V or 220V
Switch selectable, 50/60 Hz
- ↘ Full and half step (switch selectable)
- ↘ Automatic 50% idle current reduction
- ↘ Optically isolated inputs/outputs
- ↘ Tach output One pulse per motor step
- ↘ Internal Pot
- ↘ Speed (switch selectable)
10-1,200 steps/sec or 100-12,000
- ↘ External Speed Pot terminal
- ↘ Speed, Direction, Enable
- ↘ Optically isolated, 5-24v logic

RECOMMENDED MOTORS

- HT17-068
- HT17-071
- HT17-075
- HT23-394

This is a selection of the suitable motors for this drive. For more options visit the website.

INCLUDES

- ↘ Mating Connectors

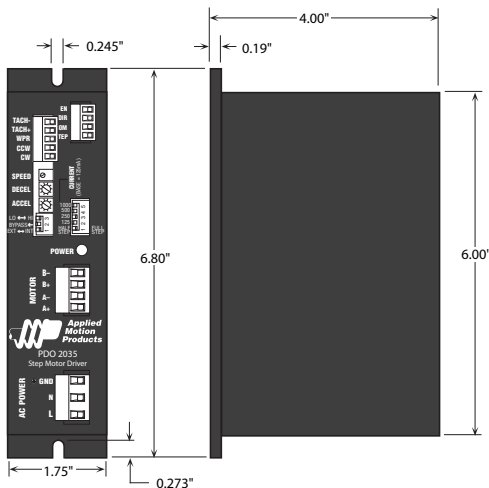

Torque curves on page 54

PDO3540 - PULSE AND DIRECTION DRIVE WITH DIGITAL OSCILLATOR

QUICKLINK: PD03540



SPECIFICATIONS

Output Current: **3.5 A**
 DC Bus Voltage: **40 VDC**
 AC Input Voltage: **110-220 single phase**

WEIGHT
 5 lbs

FEATURES

- ↘ AC input 110V or 220V
Switch selectable, 50-60 Hz
- ↘ Microstepping
200-50800
- ↘ Automatic 50% idle current reduction
- ↘ Optically isolated inputs/outputs
- ↘ Tach output - 100 pulses per revolution
- ↘ Internal Pot
- ↘ Speed (switch selectable)
0-5 rev/sec, 0-25 rev/sec
- ↘ External Speed Pot terminal
- ↘ Speed, Direction, Enable:
Optically isolated, 5-24 V logic

INCLUDES

- ↘ Mating Connectors

RECOMMENDED MOTORS

- HT17-075
- HT23-394
- HT23-397
- HT23-400

This is a selection of the suitable motors for this drive. For more options visit the website.

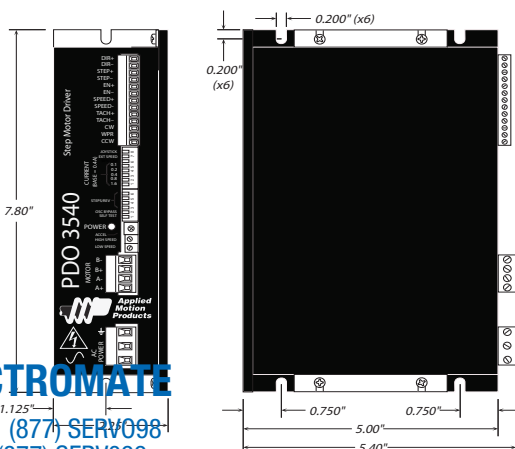

Torque curves on page 54

Sold & Serviced By:



Toll Free Phone (877) SERV098
 Toll Free Fax (877) SERV099
www.electromate.com
sales@electromate.com

PDO5580 - PULSE AND DIRECTION DRIVE WITH DIGITAL OSCILLATOR

QUICKLINK: PD05580



SPECIFICATIONS

Output Current: **5.5 A**
 DC Bus Voltage: **80 VDC**
 AC Input Voltage: **110-220 Single Phase**

WEIGHT 
 7.8 lbs

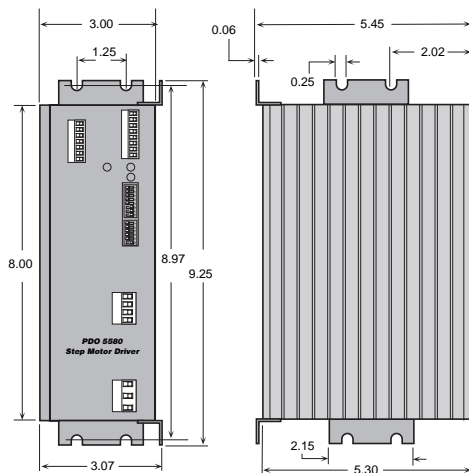

FEATURES

- ↘ AC input 110V or 220V
Switch selectable, 50/60 Hz
- ↘ Microstepping
200-50800
- ↘ Automatic 50% idle current reduction
- ↘ Optically isolated inputs/outputs
- ↘ Tach output - 100 pulses per revolution
- ↘ Internal Pot
- ↘ Speed (switch selectable)
0-5 rev/sec, 0-25 rev/sec
- ↘ External Speed Pot terminal
- ↘ Speed, Direction, Enable inputs
- ↘ Optically isolated, 5-24 V logic

INCLUDES

- ↘ Mating Connectors

RECOMMENDED MOTORS

- HT23-398
- HT23-400
- HT34-474
- HT34-478

This is a selection of the suitable motors for this drive. For more options visit the website.

Torque curves on page 55 

Sold & Serviced By:

 **ELECTROMATE**

Toll Free Phone (877) SERV098

Toll Free Fax (877) SERV099

www.electromate.com

sales@electromate.com



PDO 2035 -TORQUE CURVES

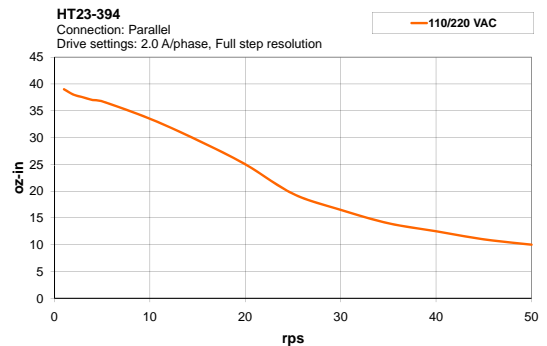
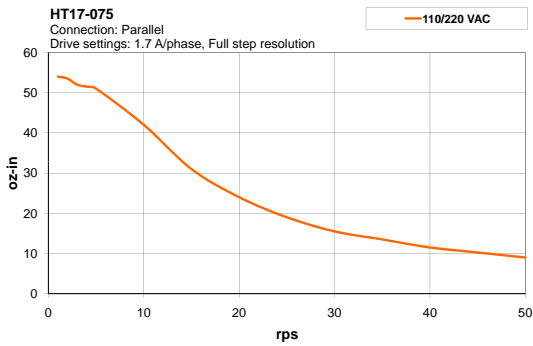
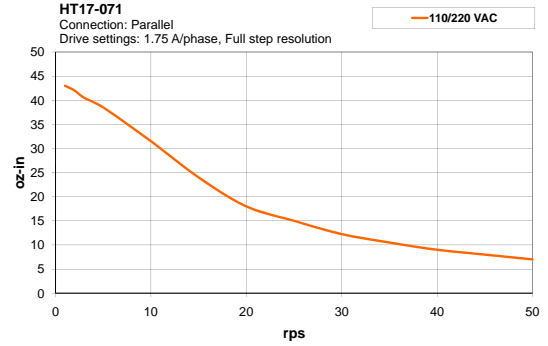
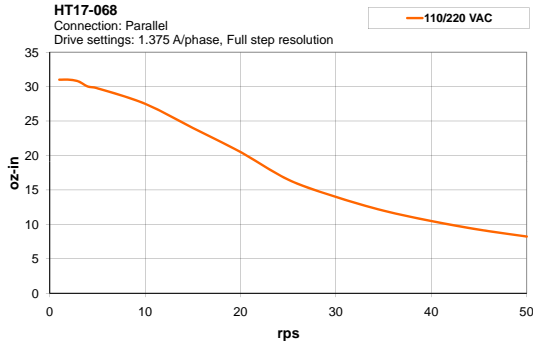

PDO3540 -TORQUE CURVES

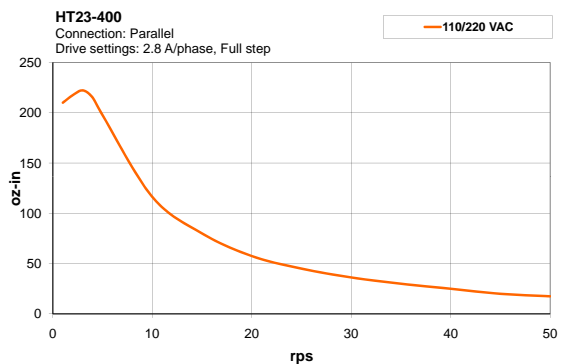
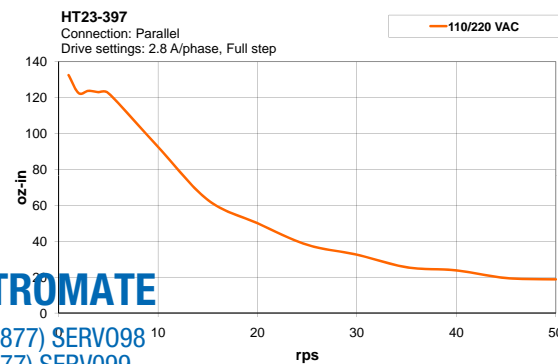
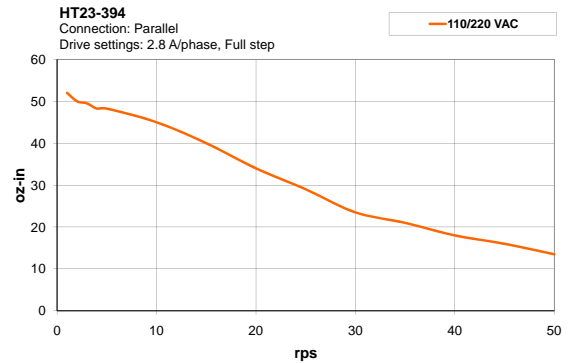
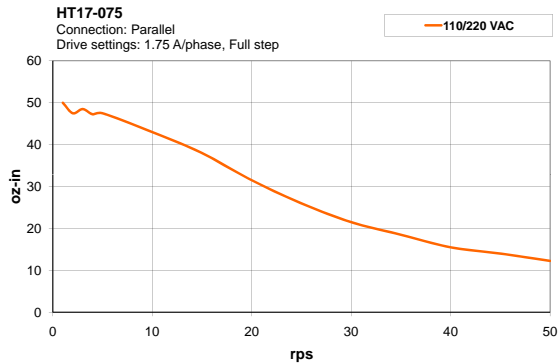

Sold & Serviced By:



Toll Free Phone (877) SERV098

Toll Free Fax (877) SERV099

www.electromate.com

sales@electromate.com

PDO 5580 - TORQUE CURVES

HT23-398

Connection: Parallel
Drive settings: 4.3A/phase, Full step resolution

110/220 VAC

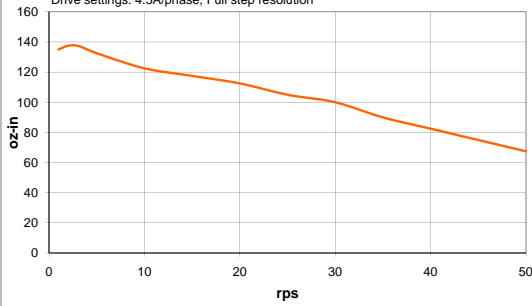

HT23-401

Connection: Parallel
Drive settings: 4.3A/phase, Full step resolution

110/220 VAC

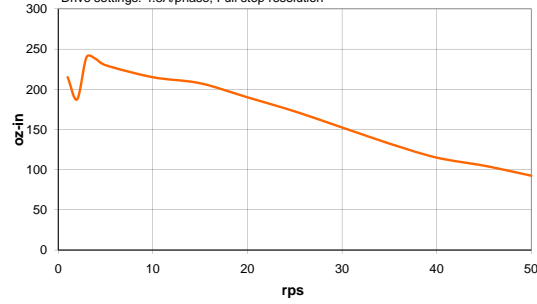

HT34-474

Connection: Parallel
Drive settings: 5.5A/phase, Full step resolution

110/220 VAC

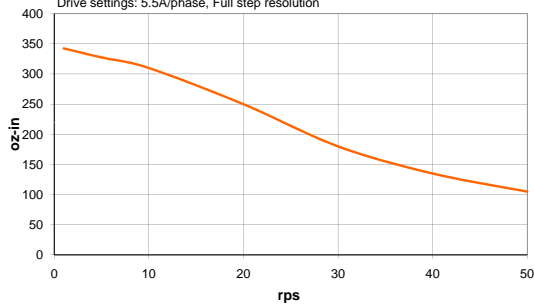

HT34-478

Connection: Parallel
Drive settings: 5.5A/phase, Full step resolution

110/220 VAC

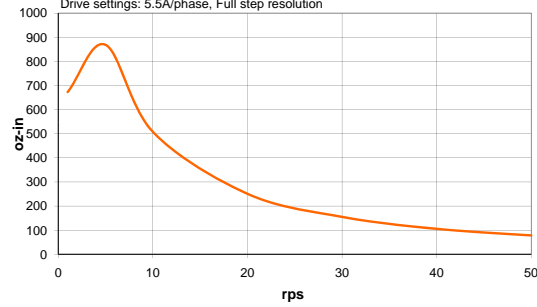

Sold & Serviced By:



Toll Free Phone (877) SERV098

Toll Free Fax (877) SERV099

www.electromate.com

sales@electromate.com



This page has been intentionally left blank

Sold & Serviced By:

 **ELECTROMATE**

Toll Free Phone (877) SERV098

Toll Free Fax (877) SERV099

www.electromate.com

sales@electromate.com

Controls & Accessories

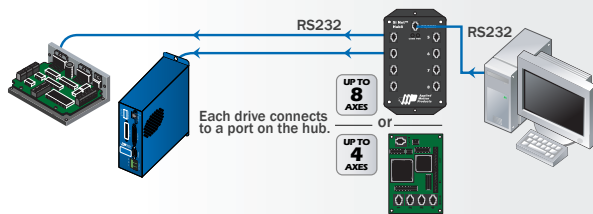

MULTI AXIS SYSTEMS

Use SiNet™ Hub Programmer software to develop your sequence of events, then download them to the hub for a stand-alone system or send serial commands to the drives from a PC, PLC, HMI, or other host controller.

SiNet™ Hub444 - 4 AXIS PROGRAMMABLE HUB

QUICKLINK: HUB444



DESCRIPTION

For use with all Si, i and S series drives to create a 4 axis motion control system using SiNet™ Hub Programmer

FEATURES

- 4 Axis control
- 4 user Inputs / 4 User Outputs

INCLUDES

- Software & Programming Cable

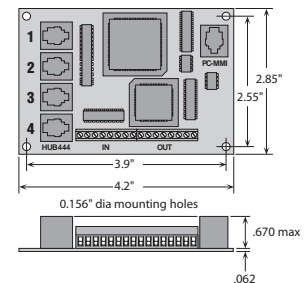

SiNet™ Hub8 - 8 AXIS PROGRAMMABLE HUB

QUICKLINK: HUB8



DESCRIPTION

For use with all Si, i and S series drives to create an 8 axis motion control system using SiNet Hub Programmer.

FEATURES

- 8 Axis control
- Compatible with all I, Si and S Series drives

INCLUDES

- Software & Programming Cable

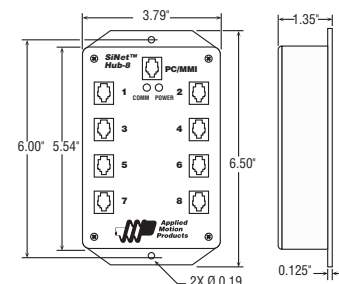

Sold & Serviced By:



Toll Free Phone (877) SERV098
 Toll Free Fax (877) SERV099
www.electromate.com
sales@electromate.com



PS430 - UNREGULATED POWER SUPPLY

QUICKLINK: ps430

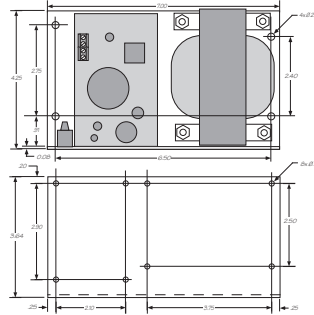

SPECIFICATIONS

Output Current: **4.0 A**
DC Bus Voltage: **30 VDC**

FEATURES

- 30VDC 4 A unregulated power supply
- 5VDC +/-5% output
- Fuse protected outputs
- Screw terminal AC connector
- 120 or 240 VAC input
- Power on Leds

PS1050 - UNREGULATED POWER SUPPLY

QUICKLINK: ps1050

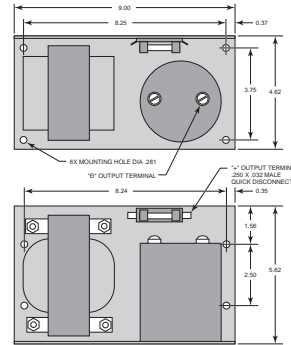

SPECIFICATIONS

Output Current: **10.0 A**
DC Bus Voltage: **50 VDC**

FEATURES

- 50VDC 10 A unregulated power supply
- Fuse protected outputs
- Screw terminal AC connector
- 120 or 240 VAC input

Sold & Serviced By:



Toll Free Phone (877) SERV098
Toll Free Fax (877) SERV099
www.electromate.com
sales@electromate.com

MMI - OPERATOR INTERFACE FOR USE WITH SI SOFTWARE

QUICKLINK: mmi



FEATURES

- Compatible with Si Programmer™ software
- 4 Line 20 character display
- 20 key tactile keypad
- NEMA 4/12 rating
- Dust-proof and drip proof when properly mounted
- Power is supplied by the drive - no additional power supply required

INCLUDES

- Cables

MODELS

MMI-01- base version
MMI-02- backlit version

BOB1/BOB2

QUICKLINK: bob



DESCRIPTION

For use in prototyping systems or for users who want the ability to change connections. The BOB units take the D type connections and spread them out to screw terminals.

FEATURES

- Break out 25 pin 'D' Connectors to screw terminals

INCLUDES

- 3' cable

COMPATIBLE WITH

- Si 2035 (BOB 1 only)
- ST5-Q (BOB 1 only)
- ST10-Q (BOB 1 only)
- ST5-Si (BOB 1 only)
- ST10-Si (BOB 1 only)
- All STAC6 Models
- All BLu Series Drives

RC-050 - REGENERATION CLAMP

QUICKLINK: rc-050

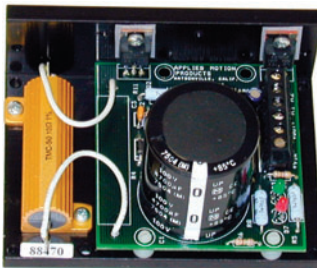

DESCRIPTION

for use with DC input drives to prevent regenerative voltage damaging the drive. Install between drive and power supply.

SPECIFICATIONS

Input Power -cont: **50W**
Input Power -peak: **800w**
Voltage range: **24-80VDC**

FEATURES

- Voltage Range 24 TO 80VDC
- Regen present LED
- Power LED
- Size 3" x 4" x 2.25"
- 50 Watt power dissipation

This page has been intentionally left blank

Sold & Serviced By:

 **ELECTROMATE**

Toll Free Phone (877) SERV098

Toll Free Fax (877) SERV099

www.electromate.com

sales@electromate.com

Stepper motors

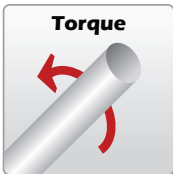

Complementing our range of drives, Applied Motion offers a wide range of step motors from NEMA 08 to 34 frame size. Motors can be supplied with encoders, gearheads or custom modifications.

NEMA 08 - HIGH PERFORMANCE STEPPER MOTOR

QUICKLINK: nema08

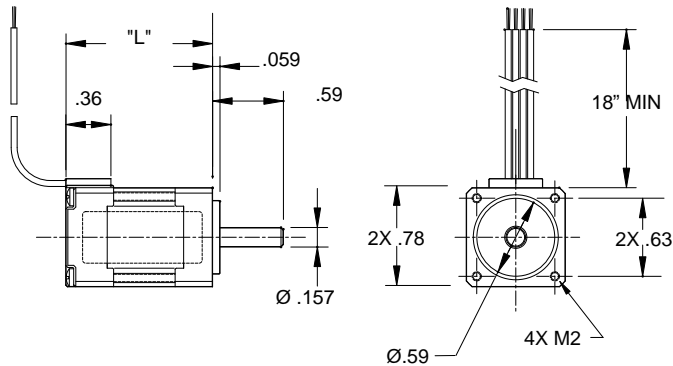
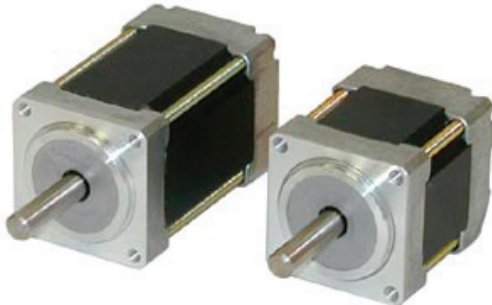

PART #	WIRING DIAG	CONNECTION	MOTOR LENGTH (INCH)	MIN-HOLDING TORQUE (OZ-IN)	# OF LEADS	STEP ANGLE (DEG)	AMPS	OHMS	MH	ROTOR INERTIA (OZ-IN ² / G-CM ²)	MOTOR WEIGHT (LBS.)
HT08-020	A	bipolar	1.18	2.4	4	1.8	0.35	8.5	3.4	0.01 / 1.9	0.11
HT08-021	A	bipolar	1.83	4.44	4	1.8	0.35	16	7.2	0.022 / 4	0.187

Use Wiring Diagram A. - page. 73.

Part numbers listed are for single shaft. To order double shaft add "D" to the end of the part number. Example: HT08-021D.

Full CAD drawings and 3D models are available on our website.

Sold & Serviced By:

 **ELECTROMATE**

Toll Free Phone (877) SERV098

Toll Free Fax (877) SERV099

www.electromate.com

sales@electromate.com

NEMA 11 - HIGH PERFORMANCE STEPPER MOTOR

QUICKLINK: nema11

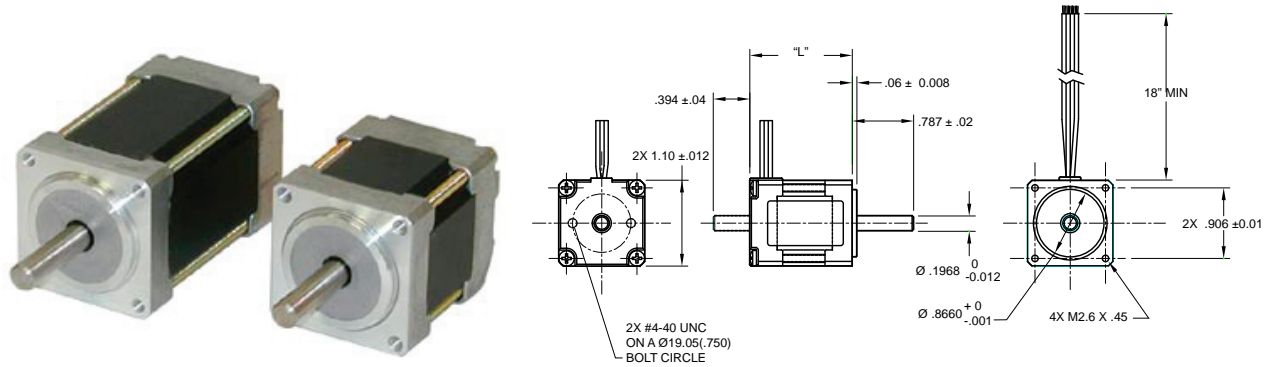

PART #	WIRING DIAG	CONNECTION	MOTOR LENGTH (INCH)	MIN-HOLDING TORQUE (OZ-IN)	# OF LEADS	STEP ANGLE (DEG)	AMPS	OHMS	MH	ROTOR INERTIA (OZ-IN ² / G-CM ²)	MOTOR WEIGHT (LBS.)
HT11-012	A	bipolar	1.32	7.0	4	1.8	1.0	1.4	1.4	0.044 / 8	0.26
HT11-013	A	bipolar	1.87	15	4	1.8	1.0	2.0	2.6	0.098 / 18	0.39

Use Wiring Diagram A. - page. 73.

Part numbers listed are for single shaft. To order double shaft add "D" to the part number. Example: HT11-012D.

Drawing shown with optional rear shaft.

Encoder holes only on dual shaft version.

Full CAD drawings and 3D models are available on our website.

NEMA 14 - HIGH PERFORMANCE STEPPER MOTOR

QUICKLINK: nema14

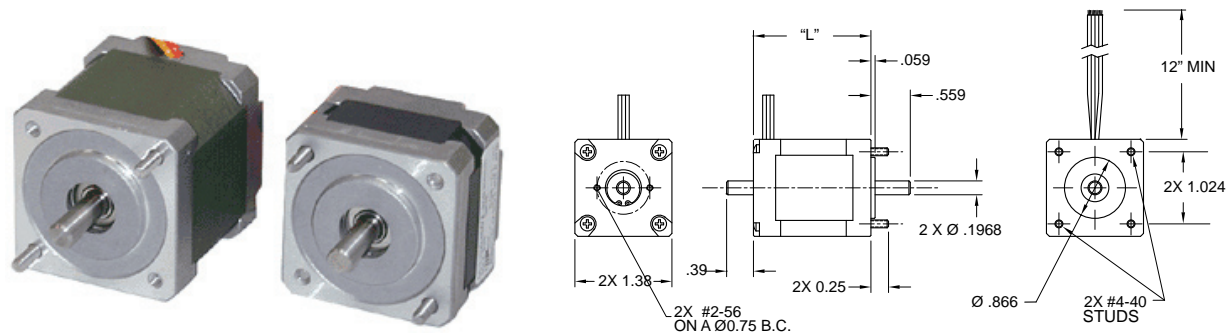

PART #	WIRING DIAG	CONNECTION	MOTOR LENGTH (INCH)	MIN-HOLDING TORQUE (OZ-IN)	# OF LEADS	STEP ANGLE (DEG)	AMPS	OHMS	MH	ROTOR INERTIA (OZ-IN ² / G-CM ²)	MOTOR WEIGHT (LBS.)
5014-820	A	bipolar	1.00	8.0	4	1.8	0.35	8.3	7.5	0.051 / 9.3	0.33
5014-842	A	bipolar	1.57	26.0	4	1.8	1.0	4.3	5.5	0.109 / 20	0.47

Use Wiring Diagram A - page. 73.

Part numbers listed are for single shaft. To order double shaft add "D" to the part number. Example: 5014-820D.

Drawing shown with optional rear shaft.

Encoder holes only on dual shaft version.

Full CAD drawings and 3D models are available on our website.

NEMA 17 - High Torque - HIGH PERFORMANCE STEPPER MOTOR

QUICKLINK: nemaht17

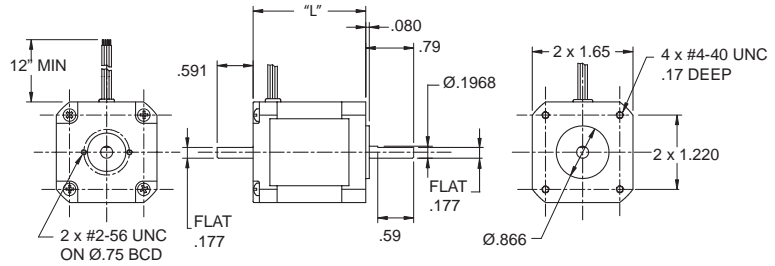

PART #	WIRING DIAG	CONNECTION	MOTOR LENGTH (INCH)	MIN-HOLDING TORQUE (OZ-IN)	# OF LEADS	STEP ANGLE (DEG)	AMPS	OHMS	MH	ROTOR INERTIA (OZ-IN ² / G-CM ²)	MOTOR WEIGHT (LBS.)
HT17-068	G	series	1.3	31.4	8	1.8	0.67	8.4	11.2	0.190/35	0.44
	F	parallel		31.4			1.34	2.1	2.8		
	E	unipolar		22.2			0.95	4.2	2.8		
HT17-071	G	series	1.54	51.0	8	1.8	0.85	6.6	14.4	0.29/54	0.57
	F	parallel		51.0			1.70	1.7	3.6		
	E	unipolar		36.1			1.20	3.3	3.6		
HT17-075	G	series	1.85	62.8	8	1.8	0.85	6.6	12.0	0.37/68	0.73
	F	parallel		62.8			1.70	1.7	3.0		
	E	unipolar		44.4			1.20	3.3	3.0		

Use Wiring Diagram E, F or G - page. 73

Part numbers listed are for single shaft. To order double shaft add "D" to the part number. Example: HT17-071D.

Drawing shown with optional rear shaft.

Encoder holes only on dual shaft version.

Full CAD drawings and 3D models are available on our website.

Sold & Serviced By:

 **ELECTROMATE**

Toll Free Phone (877) SERV098

Toll Free Fax (877) SERV099

www.electromate.com

sales@electromate.com

NEMA 23 - HIGH PERFORMANCE STEPPER MOTOR

QUICKLINK: nema23

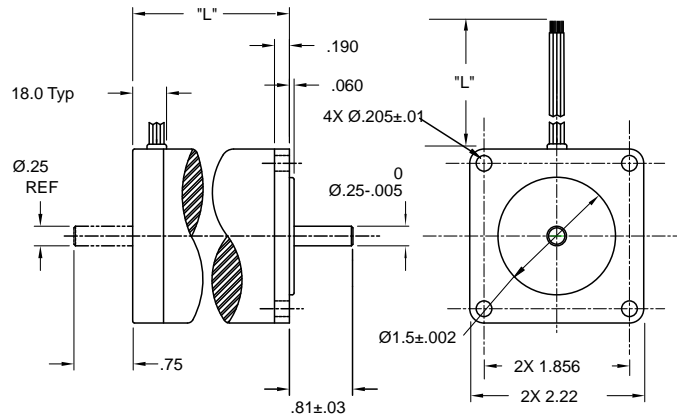

PART #	WIRING DIAG	CONNECTION	MOTOR LENGTH (INCH)	MIN-HOLDING TORQUE (OZ-IN)	# OF LEADS	STEP ANGLE (DEG)	AMPS	OHMS	MH	ROTOR INERTIA (OZ-IN ² / G-CM ²)	MOTOR WEIGHT (LBS.)
4023-819	D	series	2.0	74.9	6	1.8	0.71	10.2	40.0	0.547 / 100	1.17
	C	unipolar		53.0			1.00	5.1	10.0		
4023-820	D	series	2.0	74.9	6	1.8	2.76	0.7	1.4	0.547 / 100	1.17
	C	unipolar		53.0			3.90	0.33	0.35		
5023-100	A	bipolar	2.0	81.0	4	1.8	2.00	1.6	5.0	0.547 / 100	1.17
5023-122*	G	series	2.0	96.6	8	1.8	0.99	5.0	17.2	0.547 / 100	1.17
	F	parallel		96.6			1.98	1.3	4.3		
	E	unipolar		69.0			1.40	2.5	4.3		
4023-828	D	series	3.0	141.0	6	1.8	3.32	0.8	2.0	1.28 / 234	2.00
	C	unipolar		100.0			4.70	0.4	0.5		
4023-830	D	series	3.0	141.0	6	1.8	1.27	5.2	20.0	1.28 / 234	2.00
	C	unipolar		100.0			1.80	2.6	5.0		
5023-123*	G	series	3.0	158.0	8	1.8	1.26	4.6	18.8	1.14 / 210	2.00
	F	parallel		158.0			2.52	1.2	4.7		
	E	unipolar		112.0			1.78	2.3	4.7		
4023-835	D	series	4.0	212.0	6	1.8	2.05	2.3	9.2	1.76 / 322	2.80
	C	unipolar		150.0			2.90	1.16	2.3		
5023-124*	G	series	4.0	224.0	8	1.8	1.75	3.3	16.8	1.72 / 315	2.80
	F	parallel		224.0			3.49	0.8	4.2		
	E	unipolar		160.0			2.47	1.63	4.2		

Use Wiring Diagram as per table - Wiring diagrams are shown on page 73-74.

Part numbers listed are for single shaft. To order double shaft add "D" to the part number. Example: 4023-819D.

*Optimized for microstepping and use with 160 volt drives.

Drawing shown with optional rear shaft.

Full CAD drawings and 3D models are available on our website.

Sold & Serviced By:

 **ELECTROMATE**

Toll Free Phone (877) SERV098

Toll Free Fax (877) SERV099

www.electromate.com

sales@electromate.com

NEMA 23 - With Cable - HIGH PERFORMANCE STEPPER MOTOR

QUICKLINK: nema23

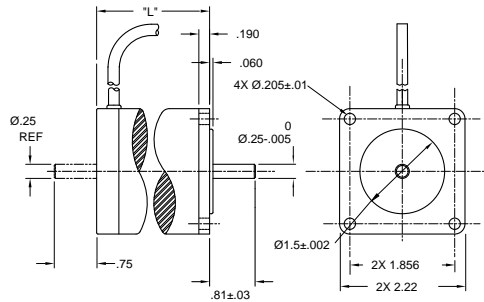

PART #	WIRING DIAG	CONNECTION	MOTOR LENGTH (INCH)	MIN-HOLDING TORQUE (OZ-IN)	# OF LEADS	STEP ANGLE (DEG)	AMPS	OHMS	MH	ROTOR INERTIA (OZ-IN ² / G-CM ²)	MOTOR WEIGHT (LBS.)
5023-167	K	series	2.0	96.6	8	1.8	0.99	5.7	17.2	0.547/100	1.17
	J	parallel		96.6			1.98	1.42	4.3		
	H	unipolar		69.0			1.40	2.85	4.3		
5023-168	K	series	3.0	158.0	8	1.8	1.26	5.6	18.8	1.14/210	2.00
	J	parallel		158.0			2.52	1.4	4.7		
	H	unipolar		112.0			1.78	2.3	4.7		
5023-169	K	series	4.0	224.0	8	1.8	1.75	4.0	16.8	1.72/315	3.12
	J	parallel		224.0			3.49	1.0	4.2		
	H	unipolar		160.0			2.47	2.0	4.2		

Use Wiring Diagram H, J or K - pages. 73-74

Part numbers listed are for single shaft. To order double shaft add "D" to the part number. Example: 5023-167D.

Motors in the table above are optimized for microstepping and use with 160 volt drives.

Motors supplied with a shielded 10 ft cable

Full CAD drawings and 3D models are available on our website.

Sold & Serviced By:

 **ELECTROMATE**

Toll Free Phone (877) SERV098

Toll Free Fax (877) SERV099

www.electromate.com

sales@electromate.com

NEMA 23 - High Torque - HIGH PERFORMANCE STEPPER MOTOR

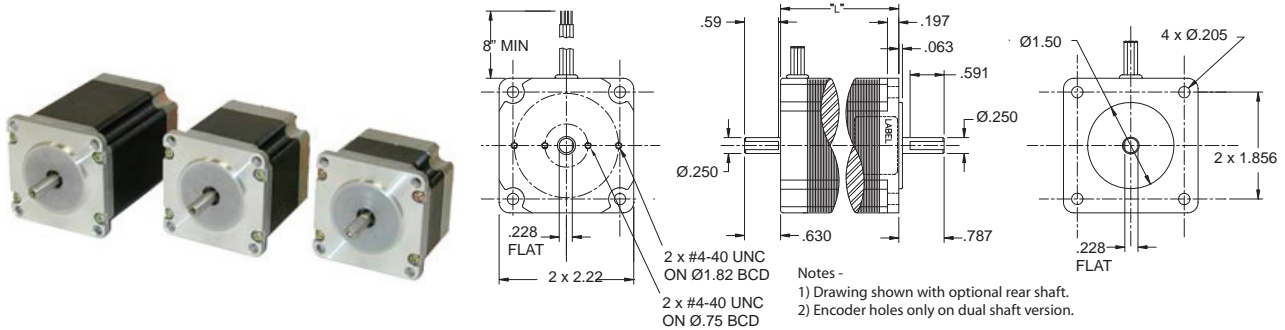
QUICKLINK: nemaht23

PART #	WIRING DIAG	CONNECTION	MOTOR LENGTH (INCH)	MIN-HOLDING TORQUE (OZ-IN)	# OF LEADS	STEP ANGLE (DEG)	AMPS	OHMS	MH	ROTOR INERTIA (OZ-IN ² / G-CM ²)	MOTOR WEIGHT (LBS.)
HT23-393	G	series	1.54	76.6	8	1.8	0.71	10.4	21.6	0.66 / 120	1.00
	F	parallel		76.6			1.41	2.6	5.4		
	E	unipolar		54.2			1.00	5.2	5.4		
HT23-394	G	series	1.54	76.6	8	1.8	1.41	2.8	5.6	0.66 / 120	1.00
	F	parallel		76.6			2.83	0.7	1.4		
	E	unipolar		54.2			2.00	1.4	1.4		
HT23-395	G	series	1.54	76.6	8	1.8	2.12	1.3	2.4	0.66 / 120	1.00
	F	parallel		76.6			4.24	0.3	0.6		
	E	unipolar		54.2			3.00	0.6	0.6		
HT23-396	G	series	2.13	177.0	8	1.8	0.71	14.4	44.0	1.64 / 300	1.54
	F	parallel		177.0			1.41	3.6	11.0		
	E	unipolar		125.0			1.00	7.2	11.0		
HT23-397	G	series	2.13	177.0	8	1.8	1.41	3.6	10.0	1.64 / 300	1.54
	F	parallel		177.0			2.83	0.9	2.5		
	E	unipolar		125.0			2.00	1.8	2.5		
HT23-398	G	series	2.13	177.0	8	1.8	2.12	1.5	4.8	1.64 / 300	1.54
	F	parallel		177.0			4.24	0.4	1.2		
	E	unipolar		125.0			3.00	0.8	1.2		
HT23-399	G	series	2.99	264.0	8	1.8	0.71	16.4	56.0	2.62 / 480	2.20
	F	parallel		264.0			1.41	4.1	14.0		
	E	unipolar		187.0			1.00	8.2	14.0		
HT23-400	G	series	2.99	264.0	8	1.8	1.41	4.5	14.4	2.26 / 480	2.20
	F	parallel		264.0			2.83	1.1	3.6		
	E	unipolar		187.0			2.00	2.3	3.6		
HT23-401	G	series	2.99	264.0	8	1.8	2.12	2.0	6.4	2.62 / 480	2.20
	F	parallel		264.0			4.24	0.5	1.6		
	E	unipolar		187.0			3.00	1.0	1.6		

Use Wiring Diagram E, F or G. - pg. 73-74

Part numbers listed are for single shaft. To order double shaft add "D" to the part number. Example: HT23-393D.

Motors in the table above are optimized for microstepping.

Full CAD drawings and 3D models are available on our website.

 Sold & Serviced By: 

 Toll Free Phone (877) SERV098
 Toll Free Fax (877) SERV099
www.electromate.com
sales@electromate.com

NEMA 23 - HIGH TORQUE WITH CABLE

QUICKLINK: nemaht23

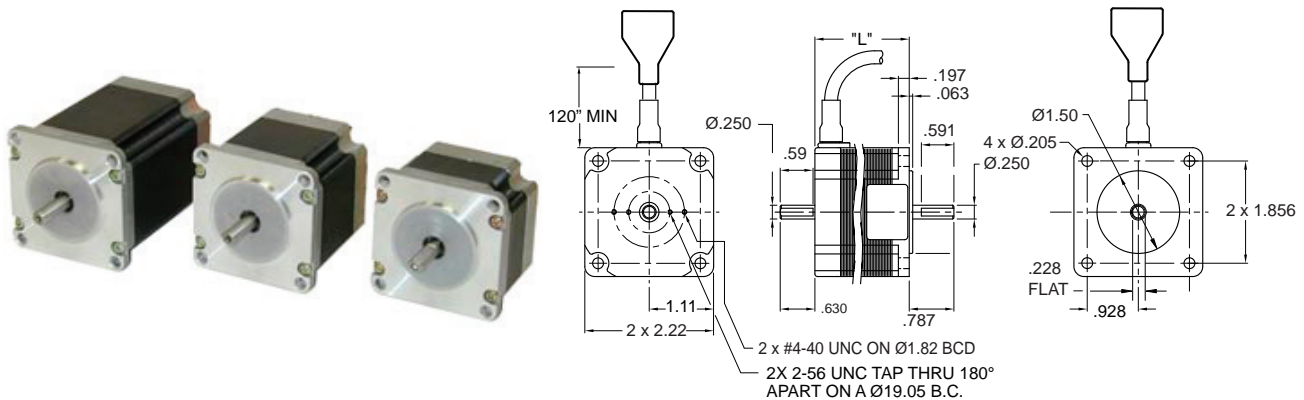

PART #	WIRING DIAG	CONNECTION	MOTOR LENGTH (INCH)	MIN-HOLDING TORQUE (OZ-IN)	# OF LEADS	STEP ANGLE (DEG)	AMPS	OHMS	MH	ROTOR INERTIA (OZ-IN ² / G-CM ²)	MOTOR WEIGHT (LBS.)
HT23-548	L	series	1.72	84.4	8	1.8	1.41	2.8	6.0	0.66 / 120	1.00
		parallel		84.4			2.83	0.7	1.5		
		unipolar		59.7			2.00	1.4	1.5		
HT23-549	L	series	2.16	167	8	1.8	1.41	3.6	12.8	1.64 / 300	1.54
		parallel		167			2.83	0.9	3.2		
		unipolar		118			2.00	1.8	3.2		
HT23-550	L	series	3.05	255	8	1.8	1.41	4.5	15.2	2.62 / 480	2.20
		parallel		255			2.83	1.13	3.8		
		unipolar		180.5			2.00	2.25	3.8		
HT23-552	L	series	1.72	84.4	8	1.8	0.7	11.2	22.4	0.66 / 120	1.00
		parallel		84.4			1.4	2.8	5.6		
		unipolar		59.7			1.00	5.6	5.6		
HT23-553	L	series	2.16	167	8	1.8	0.7	14.2	51.2	1.64 / 300	1.54
		parallel		167			1.4	3.6	12.8		
		unipolar		118			1.00	7.2	12.8		
HT23-554	L	series	3.05	255	8	1.8	0.7	18	60.8	2.62 / 480	2.20
		parallel		255			1.4	4.5	12.8		
		unipolar		180.5			1.00	9	15.2		

Use Wiring Diagram L - pg. 74

Part numbers listed are for single shaft. To order double shaft add "D" to the part number. Example: HT23-548D.

Motors in the table above are optimized for microstepping and use with 160 volt drives.

Motors in the table above are terminated in a series connection. Other connections listed for reference.

Motors supplied with a shielded 10 ft cable

Full CAD drawings and 3D models are available on our website.

Sold & Serviced By:



Toll Free Phone (877) SERV098

Toll Free Fax (877) SERV099

www.electromate.com

sales@electromate.com

NEMA 34 - HIGH PERFORMANCE STEPPER MOTOR

QUICKLINK: nema34

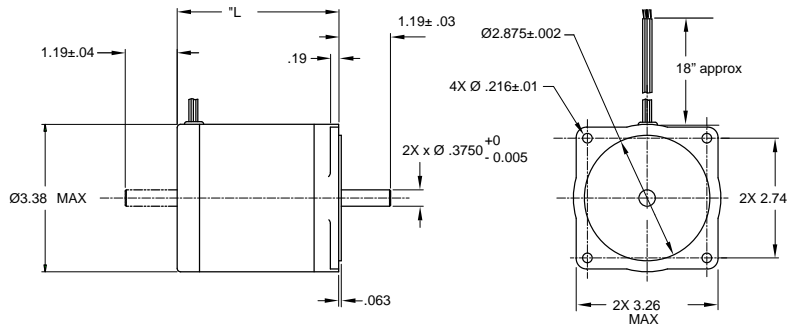

PART #	WIRING DIAG	CONNECTION	MOTOR LENGTH (INCH)	MIN-HOLDING TORQUE (OZ-IN)	# OF LEADS	STEP ANGLE (DEG)	AMPS	OHMS	MH	ROTOR INERTIA (OZ-IN ² / G-CM ²)	MOTOR WEIGHT (LBS.)
5034-348*	G	series	2.5	212.0	8	1.8	2.42	1.3	10.0	3.66 / 670	3.00
	F	parallel		212.0			4.84	0.3	2.5		
	E	unipolar		150.0			3.42	0.6	2.5		
4034-329	D	series	3.7	424.0	6	1.8	2.83	1.5	12.0	6.72 / 1230	5.40
	B	unipolar		300.0			4.00	0.8	3.0		
5034-349*	G	series	3.7	447.0	8	1.8	3.54	1.0	11.6	6.72 / 1230	5.40
	F	parallel		447.0			7.07	0.3	2.9		
	E	unipolar		316.0			5.00	0.5	2.9		
4034-334	D	series	5.1	636.0	6	1.8	2.47	2.4	28.0	10.2 / 1870	7.70
	B	unipolar		450.0			3.50	1.2	7.0		
5034-350*	G	series	5.1	667.0	8	1.8	4.17	0.8	10.4	10.2 / 1870	7.70
	F	parallel		667.0			8.34	0.2	2.6		
	E	unipolar		472.0			5.90	0.4	2.6		

Use Wiring Diagram B, D, E, F or G. - page. 73-74

Part numbers listed are for single shaft. To order double shaft add "D" to the part number. Example: 5034-349D.

*Motors optimized for microstepping and use with 160 volt drives.

Full CAD drawings and 3D models are available on our website.

Sold & Serviced By:

ELECTROMATE

Toll Free Phone (877) SERV098

Toll Free Fax (877) SERV099

www.electromate.com

sales@electromate.com

NEMA 34 - With 10' Cable - HIGH PERFORMANCE STEPPER MOTOR

QUICKLINK: nema34

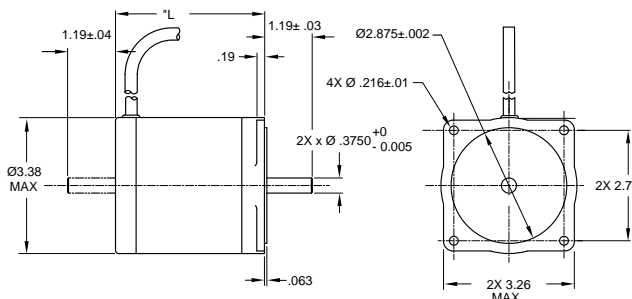

PART #	WIRING DIAG	CONNECTION	MOTOR LENGTH (INCH)	MIN-HOLDING TORQUE (OZ-IN)	# OF LEADS	STEP ANGLE (DEG)	AMPS	OHMS	MH	ROTOR INERTIA (OZ-IN ² / G-CM ²)	MOTOR WEIGHT (LBS.)
5034-367	K	series	2.5	212.0	8	1.8	2.42	1.28	10.0	3.66 / 670	3.40
	J	parallel		212.0			4.84	0.32	2.5		
	H	unipolar		150.0			3.42	0.64	2.5		
5034-368	K	series	3.7	447.0	8	1.8	3.54	1.00	11.6	6.72 / 1230	5.86
	J	parallel		447.0			7.07	0.25	2.9		
	H	unipolar		316.0			5.00	0.5	2.9		
5034-369	K	series	5.1	667.0	8	1.8	4.17	0.84	10.4	10.2/1870	8.02
	J	parallel		667.0			8.34	0.21	2.6		
	H	unipolar		472.0			5.90	0.42	2.6		

Part numbers listed are for single shaft. To order double shaft add "D" to the part number. Example: 5034-367D.

Motors in the table above are optimized for microstepping and use with 160 volt drives. Full CAD drawings and 3D models are available on our website. Use Wiring Diagram H, J or K. - page. 73-74

NEMA 34 - High Torque - HIGH PERFORMANCE STEPPER MOTOR

QUICKLINK: nemaht34

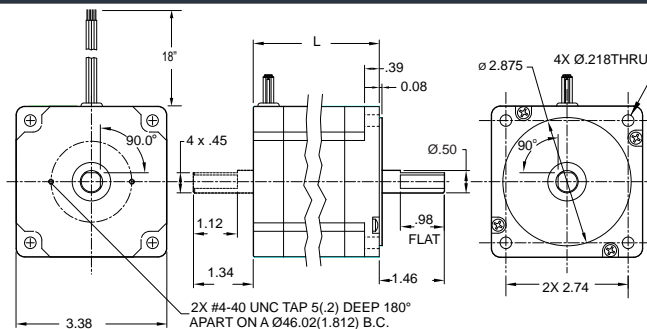

PART #	WIRING DIAG	CONNECTION	MOTOR LENGTH (INCH)	MIN-HOLDING TORQUE (OZ-IN)	# OF LEADS	STEP ANGLE (DEG)	AMPS	OHMS	MH	ROTOR INERTIA (OZ-IN ² / G-CM ²)	MOTOR WEIGHT (LBS.)
HT34-474	G	series	2.60	389	8	1.8	3.15	0.96	7.6	7.65 / 1400	4.00
	F	parallel		389			6.3	0.24	1.9		
	E	unipolar		278			4.5	0.48	1.9		
HT34-476	G	series	3.78	855	8	1.8	3.15	1.32	12.0	14.8 / 2700	6.20
	F	parallel		855			6.3	0.33	3.0		
	E	unipolar		611			4.5	0.66	3.0		
HT34-478	G	series	4.96	1284	8	1.8	2.8	1.94	22.0	21.9 / 4000	8.66
	F	parallel		1284			5.6	0.49	5.5		
	E	unipolar		917			4.0	0.97	5.5		

Part numbers listed are for single shaft. To order double shaft add "D" to the part number. Example: HT34-474D.

Motors in the table above are optimized for microstepping. Use Wiring Diagram E, F or G. - page. 73. Full CAD drawings are available on our website.

Sold & Serviced By:



Toll Free Phone (877) 575-0998

Toll Free Fax (877) 575-0999

www.electromate.com

sales@electromate.com

NEMA 34 - High Torque - Contd' -

QUICKLINK: HT34

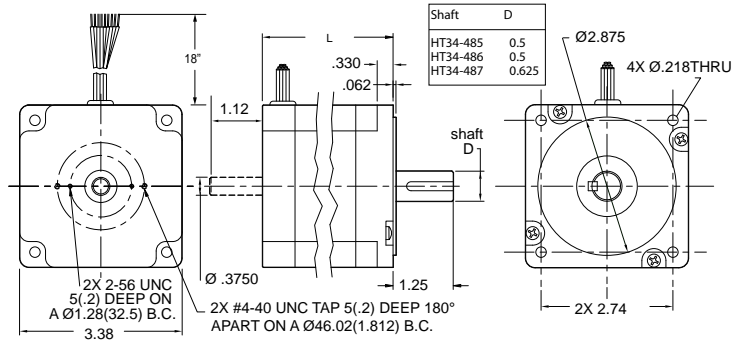
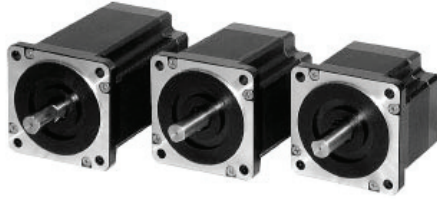

PART #	WIRING DIAG	CONNECTION	MOTOR LENGTH (INCH)	MIN-HOLDING TORQUE (OZ-IN)	# OF LEADS	STEP ANGLE (DEG)	AMPS	OHMS	MH	ROTOR INERTIA (OZ-IN ² / G-CM ²)	MOTOR WEIGHT (LBS.)
HT34-485	G	series	3.11	650	8	1.8	4.3	0.76	5.2	7.8 / 1400	6.18
	F	parallel		650			8.6	0.19	1.3		
	E	unipolar		455			6.0	0.38	1.3		
HT34-486	G	series	4.63	1200	8	1.8	4.1	1.08	8.8	14.6 / 2680	8.40
	F	parallel		1200			8.1	0.27	2.2		
	E	unipolar		840			5.7	0.54	2.2		
HT34-487	G	series	6.14	1767	8	1.8	4.5	1.08	9.6	21.9/4000	11.9
	F	parallel		1767			9.0	0.27	2.4		
	E	unipolar		1250			6.3	0.54	2.4		

Use Wiring Diagram E, F or G. - page. 73-74

Part numbers listed are for single shaft. To order double shaft add "D" to the end of the part number. Example: HT34-485D.

Motors in the table above are optimized for microstepping and use with 160 volt drives.

Motor supplied with shaft key.

Full CAD drawings and 3D models are available on our website.

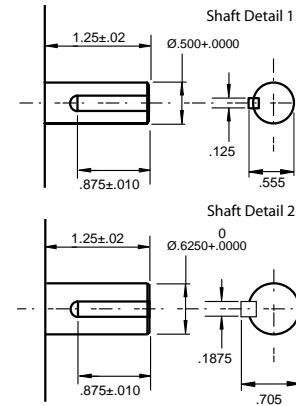

Sold & Serviced By:

ELECTROMATE

Toll Free Phone (877) SERV098

Toll Free Fax (877) SERV099

www.electromate.com

sales@electromate.com

NEMA 34 - High Torque - With Cable

QUICKLINK: HT34

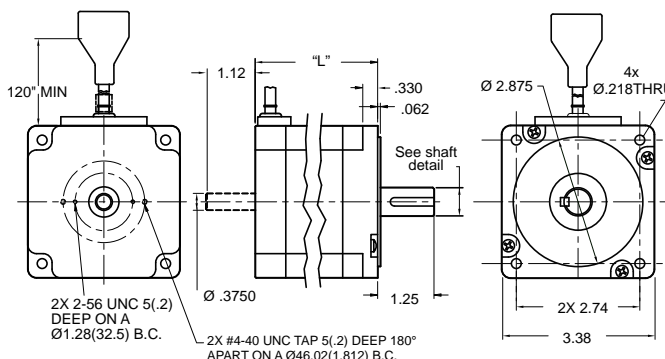

PART #	WIRING DIAG*	CONNECTION	MOTOR LENGTH (INCH)	MIN-HOLDING TORQUE (OZ-IN)	# OF LEADS	STEP ANGLE (DEG)	AMPS	OHMS#	MH#	ROTOR INERTIA (OZ-IN ² / G-CM ²)	MOTOR WEIGHT (LBS.)
HT34-488 shaft detail 1	G	series	3.11	555	8	1.8	4.3	1.4	5.2	8.7 / 1600	4.62
	F	parallel		555			8.6	0.35	1.3		
	E	unipolar		388			6.0	0.7	1.3		
HT34-489 shaft detail 1	G	series	4.63	1100	8	1.8	4.1	1.7	10.5	17.5 / 3200	7.7
	F	parallel		1100			8.1	0.42	2.6		
	E	unipolar		777			5.7	0.85	2.6		
HT34-490 shaft detail 2	G	series	6.14	1694	8	1.8	4.8	1.7	11	26.2 / 4800	11.0
	F	parallel		1694			9.6	0.42	2.8		
	E	unipolar		1186			6.8	0.85	2.8		
HT34-495 shaft detail 1	G	series	3.11	555	8	1.8	2.15	4.3	26	8.7 / 1600	4.62
	F	parallel		555			4.3	1.08	6.5		
	E	unipolar		388			3.01	2.15	6.5		
HT34-496 shaft detail 1	G	series	4.63	1110	8	1.8	2.05	5.58	42	17.5 / 3200	7.7
	F	parallel		1110			4.1	1.4	10.5		
	E	unipolar		777			2.87	2.8	10.5		
HT34-497 shaft detail 2	G	series	6.14	1694	8	1.8	2.55	5.58	45	26.2 / 4800	11.0
	F	parallel		1694			5.1	1.4	11.25		
	E	unipolar		1186			3.6	2.8	11.25		

Part numbers listed are for single shaft. To order double shaft add "D" to the end of the part number. Example: HT34-488D.

Motors in the table above are optimized for microstepping and use with 160 volt drives.

Motors in the table above are pre-wired for STAC6 - wiring diagram "L" page 73-74.

Motors supplied with a shielded 10 ft cable

* denotes wiring with connector removed

#denotes value with cable

Full CAD drawings and 3D models are available on our website.

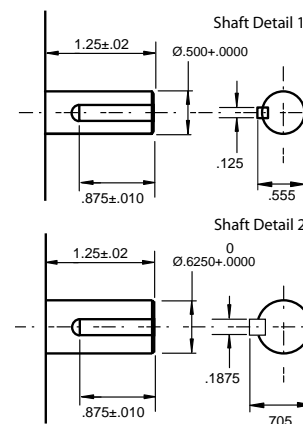

Sold & Serviced By:

ELECTROMATE

Toll Free Phone (877) SERV098

Toll Free Fax (877) SERV099

www.electromate.com

sales@electromate.com

Mechanical, Electrical & Environmental Specifications

MOTOR SERIES	STORAGE TEMPERATURE (°C)	OPERATING TEMPERATURE (°C)	INSULATION CLASS	LEAD WIRE GAUGE (AWG)	MAXIMUM RADIAL LOAD (LBS)	MAXIMUM THRUST LOAD (LBS)
HT08	-40 to +70	-20 to +50	B (130°C)	26	1	2
HT11	-40 to +70	-20 to +50	B (130°C)	26	5	3
14	-40 to +70	-20 to +50	B (130°C)	26	5	3
17	-40 to +70	-20 to +50	B (130°C)	22	5	3
HT17	-40 to +70	-20 to +50	B (130°C)	26	5	3
23	-40 to +70	-20 to +50	B (130°C)	22	15	25
HT23	-40 to +70	-20 to +50	B (130°C)	22	15	25
34	-40 to +70	-20 to +50	B (130°C)	18	25	50
HT34	-40 to +70	-20 to +50	B (130°C)	22	25	50
42	-40 to +70	-20 to +50	B (130°C)	#	25	50

- 42 frame motors have screw terminals - use 22 AWG Wire

MOTOR SERIES	SHAFT RUN OUT (INCH)	RADIAL PLAY (INCH/LBS.)	END PLAY (INCH/LBS.)	PERPENDICULARITY (INCH)	CONCENTRICITY (INCH)
HT08	0.001	0.001 max @ 1.1 lb.	0.003 max @ 2.2 lb.	0.002	0.002
HT11	0.001	0.001 max @ 1.1 lbs.	0.003 max @ 2.2 lb.	0.002	0.002
14	0.0005	0.0004 max @ 1 lb.	0.0004 max @ 2 lb.	0.003	0.002
17	0.0005	0.001 max @ 1 lb.	0.001 max @ 3 lbs.	0.003	0.002
HT17	0.0005	0.001 max @ 1.1 lbs.	0.003 max @ 2.2 lbs.	0.003	0.002
23	0.001	0.001 max @ 1 lb.	0.001 max @ 9 lbs.	0.003	0.002
HT23	0.002	0.001 max @ 1.1 lbs.	0.003 max @ 2.2 lbs.	0.003	0.002
34	0.002	0.001 max @ 1 lb.	0.001 max @ 15 lbs.	0.003	0.002
HT34	0.002	0.001 max @ 1 lb.	0.003 max @ 1 lb.	0.003	0.002
42	0.002	0.001 max @ 1 lb.	0.001 max @ 15 lbs.	0.003	0.003

Sold & Serviced By:

 **ELECTROMATE**

Toll Free Phone (877) SERV098

Toll Free Fax (877) SERV099

www.electromate.com

sales@electromate.com

Wiring Diagrams

A - 4 LEAD BIPOLAR DRIVE

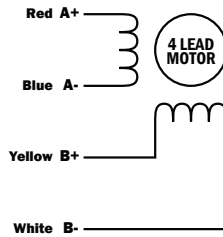

B - 6 LEAD UNIPOLAR DRIVE

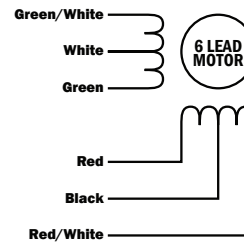

C - 6 LEAD BIPOLAR - CENTER TAP TO END

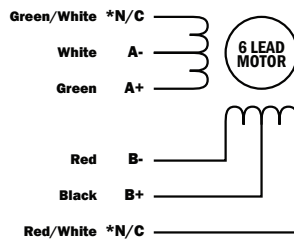

D - 6 LEAD BIPOLAR - END TO END

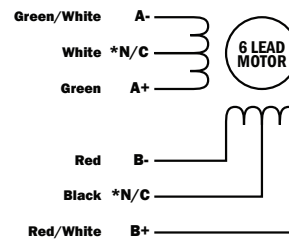

E - 8 LEAD UNIPOLAR DRIVE

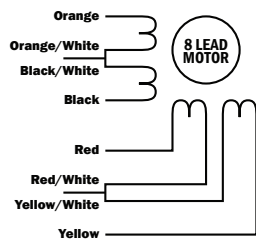

F - 8 LEAD BIPOLAR - PARALLEL

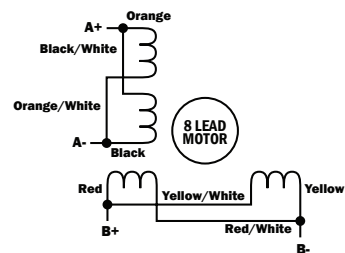

G - 8 LEAD BIPOLAR SERIES

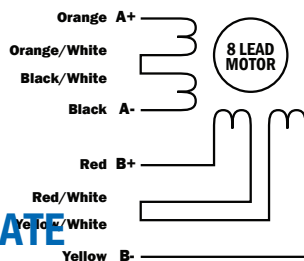

H - 8 LEAD CABLE - UNIPOLAR

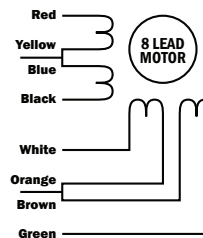

Sold & Serviced By:

ELECTROMATE

Toll Free Phone (877) SERV098

Toll Free Fax (877) SERV099

www.electromate.com

sales@electromate.com

*N/C denotes wires are not connected and are individually taped off.

J - 8 LEAD CABLE - BIPOLAR - PARALLEL

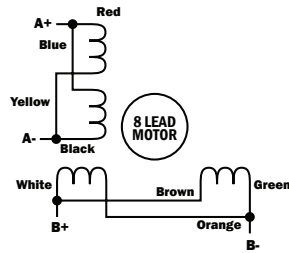

K - 8 LEAD CABLE BIPOLAR - SERIES

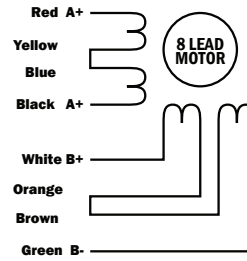

L - STAC6 Motor connections

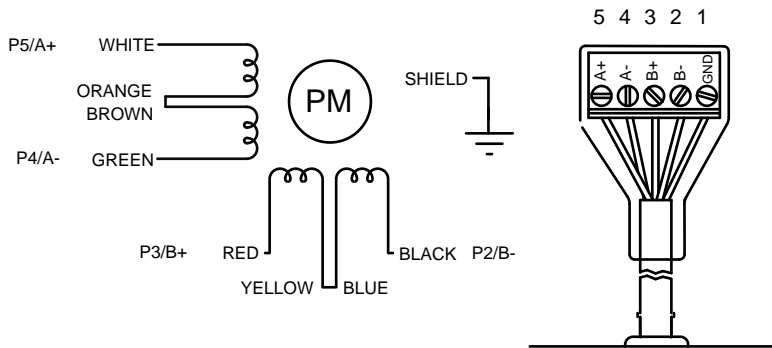

CONNECTION CHART		
PIN	CONNECTOR	LEAD COLOR
1	CASE GND	SHIELD
2	B-	BLACK
3	B+	RED
4	A-	GREEN
5	A+	WHITE

Sold & Serviced By:

ELECTROMATE

Toll Free Phone (877) SERV098

Toll Free Fax (877) SERV099

www.electromate.com

sales@electromate.com

STEP MOTOR MODIFICATIONS

CUSTOM STEP MOTORS

Not every application can use an off the shelf stock motor, that is why at Applied Motion we are ready to go to the next step.

We can supply simple modifications , such as flats on shafts, or adding a connector, in a short time. This service is available, for all customers, even those requiring just a few motors.

In some cases these motors will be prototypes for larger orders. Here we provide samples, to your specification, with a view to getting the larger quantities made at the factory at lower cost.

MODIFICATIONS INCLUDE

- ✓ Flats on shafts
- ✓ Shorter or longer shafts
- ✓ Splines and pinion shafts
- ✓ Connectors and cables
- ✓ Pins and pulleys
- ✓ Special windings
- ✓ Gearheads
- ✓ Encoders
- ✓ Brakes

CALL OR EMAIL WITH YOUR SPECIAL NEEDS.



STEP MOTORS WITH OPTIONAL ENCODER

Many applications now use an encoder to accurately determine position and velocity. Applied Motion can offer a variety of optical encoders to meet your exact needs. To see our standard offering of encoders and cables please visit our web site.

www.applied-motion.com/encoders

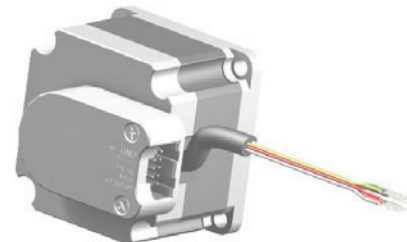
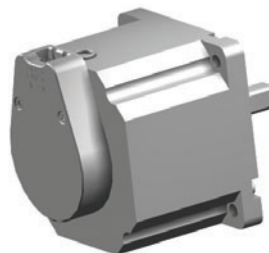

Sold & Serviced By:

 **ELECTROMATE**

Toll Free Phone (877) SERV098

Toll Free Fax (877) SERV099

www.electromate.com

sales@electromate.com



This page has been intentionally left blank

Sold & Serviced By:

 **ELECTROMATE**

Toll Free Phone (877) SERV098

Toll Free Fax (877) SERV099

www.electromate.com

sales@electromate.com

Servo Drives

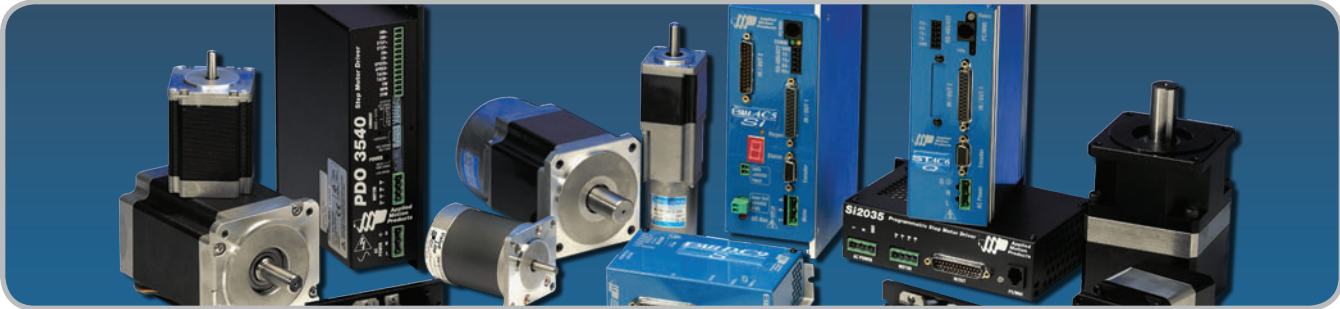

SI PROGRAMMER™

Intended for use in stand-alone applications, Si Programmer™ provides a friendly, point-and-click, graphical interface that doesn't require any previous programming experience.



Q PROGRAMMER™

Q programmer™ is intended for more experienced programmers who need a more flexible motion control tool.

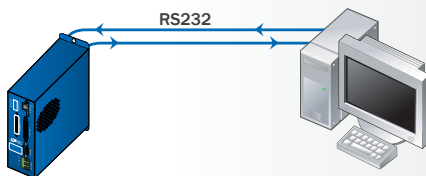

SCL™ (HOST CONTROL)

Intelligent drives can be used as part of a host controlled system. Serial Commands are streamed to the drive via an RS232 or RS 485 serial port.

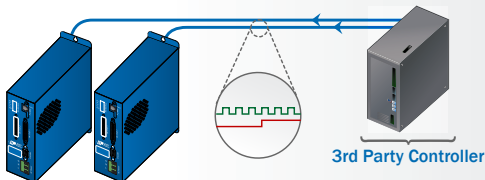

STEP AND DIRECTION

Drives are commanded via a Step and Direction signal.

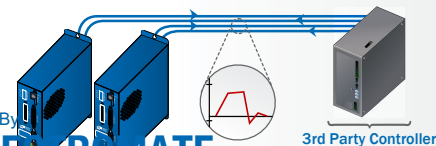

ANALOG CONTROL

Drives are controlled in Torque or Velocity mode via a +/-10v signal from a motion controller.

Sold & Serviced By

Toll Free Phone (877) SERV098
Toll Free Fax (877) SERV099
www.electromate.com
sales@electromate.com



Servo Drive - Functions

Step & Direction

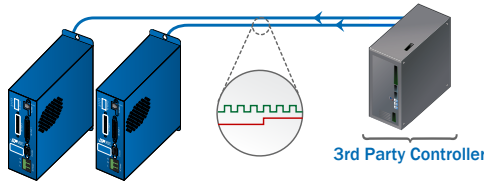

- STEP & DIRECTION
- CW & CCW PULSE
- A/B QUADRATURE

Analog Signal

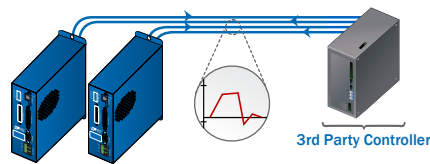

- +/-10V
- TORQUE CONTROL
- VELOCITY CONTROL
- POSITION CONTROL

Host Control

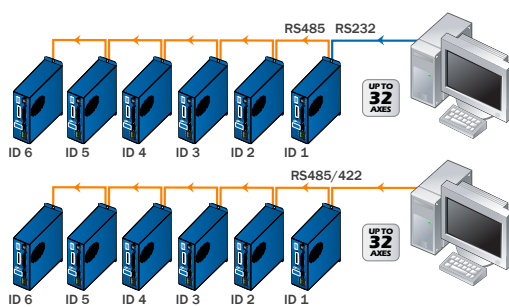

- ACCEPTS HOST COMMANDS FROM PC OR PLC
- MULTI-AXIS CAPABLE
- STREAM SERIAL COMMANDS

Stand Alone Programmable

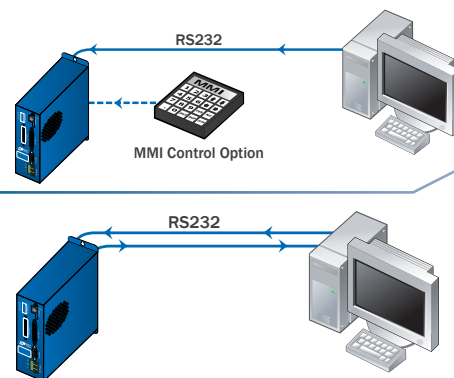

- POINT & CLICK GRAPHICAL INTERFACE
- DOWNLOAD, STORE & EXECUTE PROGRAMS
- MMI OPTION



- COMPREHENSIVE TEXT BASED LANGUAGE
- DOWNLOAD, STORE & EXECUTE PROGRAMS
- HIGH LEVEL FEATURES: MULTI TASKING, CONDITIONAL PROGRAMMING, MATH FUNCTIONS
- HOST INTERFACE WHILE EXECUTING INTERNAL PROGRAMS

Multi-axis Systems

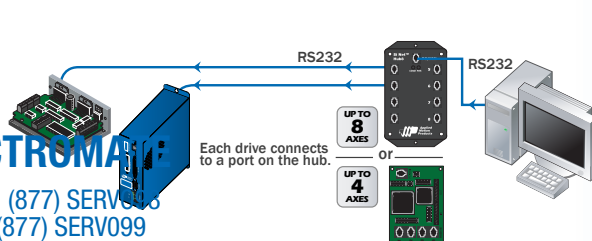

Use SiNet™ Hub Programmer software to develop your sequence of events, then download them to the hub for a stand-alone system **or** send serial commands to the drives from a PC, PLC, HMI, or other host controller.

Sold & Serviced By:

ELECTROMATE
 Toll Free Phone (877) SERV099
 Toll Free Fax (877) SERV099
www.electromate.com
sales@electromate.com

BLuDC4 - DC INPUT SERVO DRIVE

QUICKLINK: BLUDC4



SCL Compatible

Si Programmable

Q Programmable

SPECIFICATIONS

Output Current: **4.5A cont**
13.5A peak
Input Voltage: **24-48VDC**

WEIGHT

2.5 oz

CONTROL OPTIONS

- Analog Command Signal (+/- 10V)
- Pulse & Direction/CW & CCW Pulse
- Encoder Following
- Host Commands via RS-232/485
- Programmable with Si or Q

FEATURES

- Digital Servo Drive
- 24-48 VDC power supply
Continuous current of 4.5A,
Peak currents to 13.5A.
- Speeds to 6000 rpm.
Motor and load dependent
- Runs brushed or brushless motors
- Logic inputs
Alarm Reset, Limit switches, Servo enable
- Logic output functions
Alarm, Brake, in Position/Motion output

Complete Specs on page 81 ➔

SOFTWARE

- Si Programmer™
Download, store and execute programs.
- SCL Setup Utility
Send and execute serial commands
- Quick Tuner™
Easy-to-use configuration software.
- Q Programmer™
Download, store and execute programs.

RECOMMENDED MOTORS

- M0030-103-3-000 / N0030-103-A-000
- M0050-103-3-000 / N0050-103-A-000
- M0100-104-3-000 / N0100-104-A-000
- M0100-104-4-000 / N0100-104-B-000

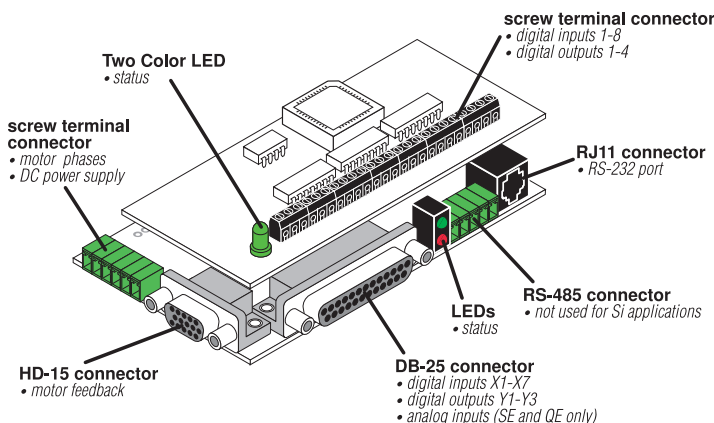

Models



- Pulse & Direction
- CW/CCW Pulse
- A/B Quadrature
- Analog Torque/Velocity mode
- Host commands (SCL™ compatible)
- SiNet™ Hub compatible
- Quick Tuner™ software for setup



- Conditional Processing
- Math Functions
- Multi-tasking
- Register Manipulation
- Encoder Following
- "Generic" HMI compatibility

- Si Programmer™ with built-in Configurator™ Friendly GUI
- Point-and-click indexing software
- I/O and motion programming
- MMI-01 compatibility

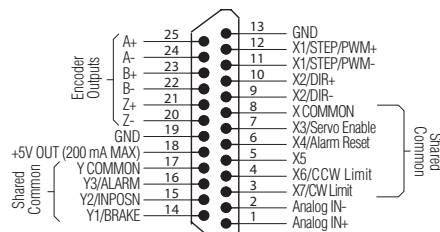

DB25 I/O Connector

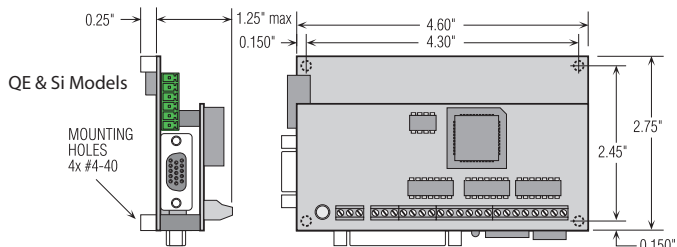
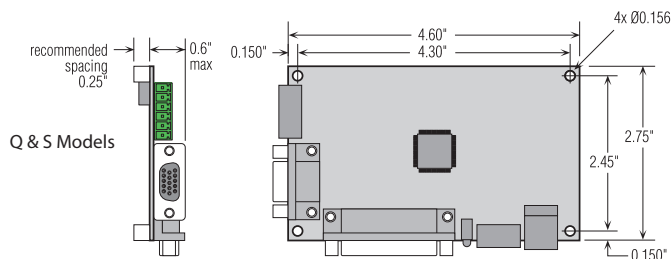

Sold & Serviced By:



Toll Free Phone (877) SERV098
Toll Free Fax (877) SERV099

www.electromate.com
sales@electromate.com

BLuDC9- DC INPUT SERVO DRIVE

QUICKLINK: bludc9



SPECIFICATIONS

Output Current: **9.0A cont**
18A peak

Input Voltage: **24-48VDC**

WEIGHT
9.5 oz

CONTROL OPTIONS

- Analog Command Signal (+/- 10V)
- Pulse & Direction/CW & CCW Pulse
- Encoder Following
- Host Commands via RS-232/485
- Programmable with Si or Q

FEATURES

- Digital servo drive
- 24-48 VDC power supply
- Continuous current of 9.0A, peak currents to 18A
- Speeds to 6000 rpm. Motor and load dependent
- 16 kHz precision PWM amplifier
- Runs brushed or brushless motors
- Logic inputs
 - Alarm Reset, limit switches, servo enable
- Logic output functions
 - Alarm, Brake, in Position/Motion output

Complete Specs on page 81 →

SCL Compatible

Si Programmable

Q Programmable

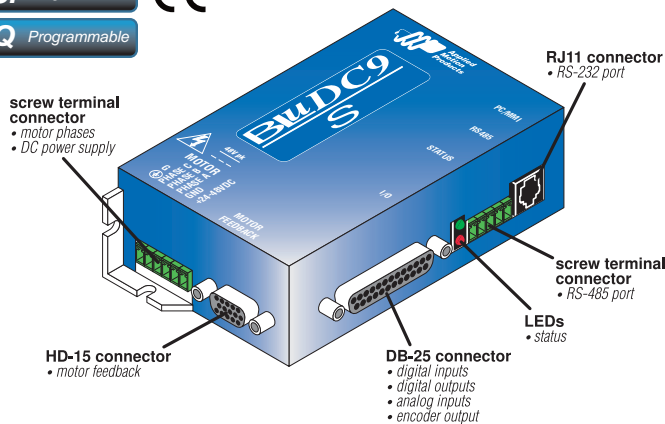

SOFTWARE

- Si Programmer™
 - Download, store and execute programs.
- SCL™ Setup Utility
 - Send and execute serial commands
- Quick Tuner™
 - Easy-to-use configuration software.
- Q Programmer™
 - Download, store and execute programs.

Software and programing cables supplied.
Go to pages 8-14 for more info

RECOMMENDED MOTORS

- M0100-104-3-000 / N0100-104-A-000
- M0100-103-4-000 / N0100-103-B-000
- M0200-104-4-000 / N0200-104-B-000
- M0400-105-4-000 / N0400-105-B-000

Models



- Pulse & Direction
- CW/CCW Pulse
- A/B Quadrature
- Analog Torque/Velocity mode
- Host commands (SCL compatible)
- SiNet™ Hub compatible
- Quick Tuner™ software for setup



- Conditional Processing
- Math Functions
- Multi-tasking
- Register Manipulation
- Encoder Following
- "Generic" HMI compatibility



- Si Programmer™ with built-in Configurator
- Point-and-click indexing software
- Friendly GUI
- I/O and motion programming
- MMI-01 compatibility

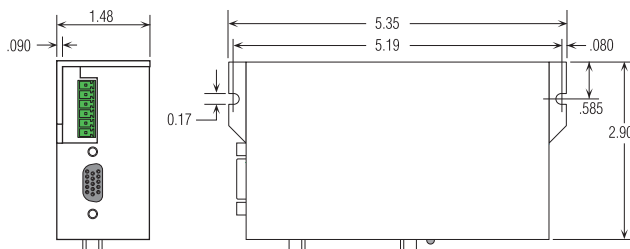
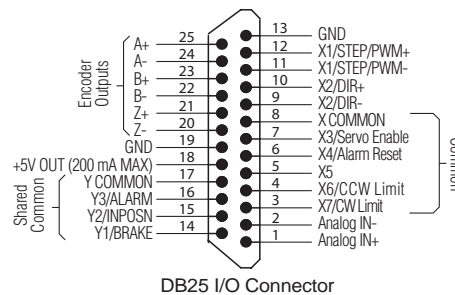

Sold & Serviced By:



Toll Free Phone (877) SERV098
Toll Free Fax (877) SERV099

www.electromate.com
sales@electromate.com

BLuDC4 and BLuDC9 technical specs.

POWER AMPLIFIER SPECIFICATIONS

AMPLIFIER TYPE	3-phase sinusoidally commutated with MOSFET power devices
CURRENT CONTROL	4 quadrant "DQ" method with PWM at 16 kHz
OUTPUT CURRENT	BLuDC4 4.5 A continuous / 13.5 A peak BLuDC9 9.0 A continuous / 18.0 A peak
DC INPUT VOLTAGE	24 - 48 VDC (18 VDC minimum, 53 VDC maximum)
REGENERATION	Requires external regen clamp board: RC-050.
CIRCUIT PROTECTION	Over-current / Short circuit, Over temperature, Over voltage, Under voltage, Encoder signal failure, Hall signal failure
POSITION FEEDBACK	A/B quadrature incremental encoder, 200 - 128,000 counts/rev (50 - 32,000 lines), 2 MHz maximum frequency.
POSITION RESOLUTION	Set via software to match incremental encoder resolution.
MAXIMUM MOTOR SPEED	6000 RPM, motor and load dependent.

CONTROL SPECIFICATIONS

SERVO/MOTION UPDATE	4 kHz
SERIAL COMMUNICATION	RS-232 programming and control port. Green and Red LED's for indicating receive & transmit activity. S & Q drives also can be controlled via RS-422/485 port and are addressable for multi-axis control via this port. Both ports (RS-232 & RS-422/485) selectable baud: 9600, 19200, 38400, 57600, 115200.
STATUS INDICATORS	Green and Red LED's indicate communication activity over serial ports, drive status, and drive alarm codes (faults).
DIGITAL INPUTS & OUTPUTS	All optically isolated 5-24 V logic; 2 high speed, 5 V logic inputs for Step (Pulse) & Direction and Encoder Following control.
ANALOG INPUT	S & Q drives only: configurable as single-ended or differential +/- 10V, +/- 5V, 0-10V, 0-5V. Can be used as one differential input or two single-ended inputs. 12-bit resolution (including sign).
S & Q PARAMETER RANGES	Distance: 1 - 2,147,483,647 CW or CCW, relative or absolute positioning in encoder counts. Speed: 0.0042 - 133 rev/sec Acceleration: 0.167 - 5000 rev/sec/sec Deceleration: 0.167 - 5000 rev/sec/sec Time Delays: 0.01 - 320 seconds
SI PARAMETER RANGES	Distance: 1 - 16,000,000 CW or CCW, absolute position +/- 2 billion. Speed: 0.125 - 100 rev/sec Acceleration: 1 - 3000 rev/sec/sec Deceleration: 1 - 3000 rev/sec/sec Time Delays: 0.01 - 300 seconds Output Pulse Widths: 2 - 500 milliseconds Iterations per loop: 1 - 65,535 Nested loops: 50 maximum Subroutine call: 5 deep maximum
PHYSICAL	AMBIENT TEMPERATURE: 0 - 40°C HUMIDITY: Maximum of 90% non-condensing CONNECTORS: Screw terminal connectors for input power and motor, HD-15 for encoder/hall signals, DB25 for I/O. Si, SE, and QE have DB25P for additional I/O.

INPUTS AND OUTPUTS

DRIVE MODEL	TOTAL I/O	DEDICATED INPUTS*		GENERAL PURPOSE INPUTS	DEDICATED OUTPUTS**		GENERAL PURPOSE OUTPUTS	ANALOG INPUTS
BLuDC9-S BLuDC4-S	7/3	6	Limit Switches (2), Alarm Reset Servo Enable, Jog CW, CCW (2)	1	3	Alarm Motion Brake	0	2 single-ended or 1 differential
BLuDC9-Q BLuDC4-Q	7/3	6	Limit Switches (2), Alarm Reset Servo Enable, Jog CW, CCW (2)	1	3	Alarm Motion Brake	0	2 single-ended or 1 differential
BLuDC9-Si BLuDC4-Si	15/7	4	Limit Switches (2) Jog CW, CCW (2)	11	3	Alarm Motion Brake	4	0

*Dedicated Inputs can be re-defined as General Purpose Inputs through software.

**Dedicated Outputs can be re-defined as General Purpose Outputs through software.

Sold & Serviced By:



NOTE: Expansion I/O can be added to S and Q drives making them SE and QE drives:

6 additional inputs and 4 additional outputs.

NOTE: The encoder's index (Z) channel if present can be used as an additional "home" input.

Toll Free Phone (877) SERV098

Toll Free Fax (877) SERV099

www.electromate.com

sales@electromate.com

BLuAC5 - AC INPUT SERVO DRIVE

QUICKLINK: BLUAC



SPECIFICATIONS

Output Current - **5.0A cont 15A peak**
 Input Voltage - **90 - 265 VAC**
 Single / three phase

WEIGHT

2lbs 13 oz

CONTROL OPTIONS

- Analog Command Signal (+/- 10V)
- Pulse & Direction/CW & CCW Pulse
- Encoder Following
- Host Commands via RS-232/485
- Programmable with Si or Q

SCL Compatible

Si Programmable

Q Programmable

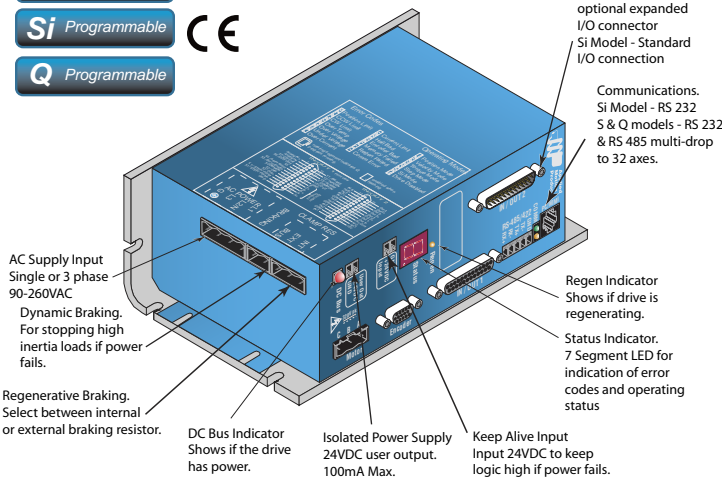

FEATURES

- Torque, velocity, positioning, and programmable modes.
- Speeds to 8000 rpm
- 16 kHz precision PWM amplifier.
- Internal regeneration circuit and power resistor.
- Encoder/motor connection Wizard
- 2 to 24 pole brushless motor compatibility.

SOFTWARE

- Si Programmer™ Download, store and execute programs.
- SCL™ Setup Utility Stream serial commnds.
- Quick Tuner™ Easy to use configuration software.
- Q Programmer™ Download, store and execute programs.

Software and programming cables supplied.
 Go to page 8-14 for more info...

RECOMMENDED MOTORS

- M0400-101-4-000 / N0400-102-B-000
- M0400-102-5-000 / N0400-102-C-000
- M0600-102-5-000 / N0600-102-C-000
- M0750-102-5-000 / N0750-102-C-000

Visit: www.applied-motion.com for torque curves and other tech data.

Models



- Pulse & Direction
- CW/CCW Pulse
- A/B Quadrature
- Analog Torque/Velocity mode
- Host commands (SCL compatible)
- SiNet™ Hub compatible
- Quick Tuner™ software for setup



- Conditional Processing
- Math Functions
- Multi-tasking
- Register Manipulation
- Encoder Following
- "Generic" HMI compatibility

- Si Programmer™ with built-in Quick Tuner™
- Point-and-click indexing software
- Friendly GUI
- HMI-01 compatibility

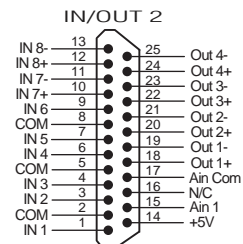
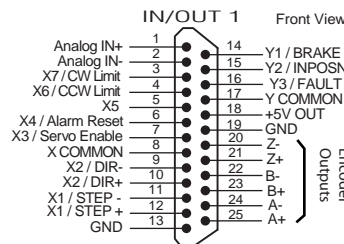
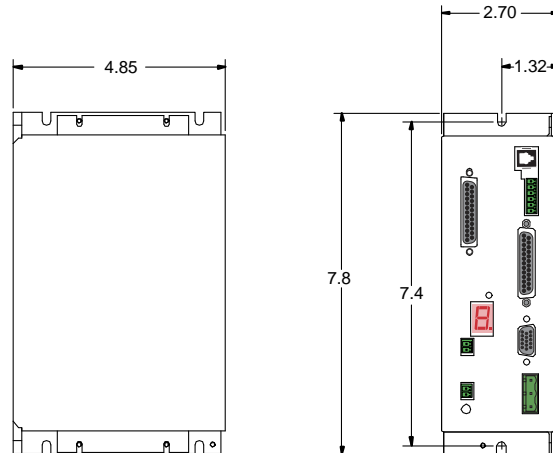

Note - this connector is standard on Si version and only on S and Q versions with expanded I/O.

Sold & Serviced By:



Toll Free Phone (877) SERV099
 Toll Free Fax (877) SERV099
www.electromate.com
sales@electromate.com

BLuAC5 Technical specs.

POWER AMPLIFIER SPECIFICATIONS

AMPLIFIER TYPE	3 phase Sinusoidal PWM switching at 16 KHz.
CURRENT CONTROL	4 quadrant "DQ" method
OUTPUT CURRENT	5 amps continuous. 15 amps peak current, one second max rms.
AC INPUT VOLTAGE	90 - 260VAC 50/60Hz, 1 phase or 3 phase
REGENERATION	50 Watt internal shunt resistor. Connector for high power external shunt resistor.
CIRCUIT PROTECTION	Over-current/short circuit Over temperature (75°C) Over voltage (400VDC on DC Bus) Under voltage (100VDC on DC Bus) Regeneration Error (Based on Regeneration values) Encoder Failure (When using differential input) Hall sensor Failure
POSITION FEEDBACK	Incremental Encoder, A/B Quadrature (50 to 32,000 line), up to 2MHz.
POSITION RESOLUTION	Set via software to match encoder resolutions from a minimum of 50 lines to a maximum of 32,000 lines per revolution producing a minimum of 200 counts to a maximum of 128,000 counts per revolution in quadrature.
MAXIMUM MOTOR SPEED	Speeds to 8000 rpm. Motor and load dependent.

CONTROL SPECIFICATIONS

MOTION/SERVO UPDATE	4 kHz
SERIAL COMMUNICATION	RS-232 or RS-422/RS-485 programming & control port (RS-485 S & Q versions only). Green and Amber LED's for Receive and Transmit indication. Each drive is addressable for multi-axis control (S & Q versions only). Selectable Baud rates of 9600, 19200, 38400, 57600, 115200.
STATUS INDICATORS	7-Segment LED for Status, Operation and Error code display
DIGITAL INPUTS & OUTPUTS	All Optically Isolated, 2 high speed inputs for Encoder Following or Step & Direction input.
ANALOG INPUT	Configurable as single-ended or differential ±10V, ±5V, 0-5V or 0-10V. This can be read as one differential or two single ended inputs, dependent on software application. Si;Not Supported, S model; one input Single or Differential, Q; One Single or Differential or two Single Ended.
S & Q PARAMETER RANGES	Distance: 1 to 2,147,483,647 (CW or CCW), relative or absolute position in encoder counts. Speed: .0042 to 133 revolutions per second. Acceleration: 0.167 to 5,000 rev/sec/sec. Deceleration: 0.167 to 5,000 rev/sec/sec (set independently from acceleration). Time Delays: .01 to 320 seconds.
SI PARAMETER RANGES	Distance: 1 to 16,000,000 (CW or CCW), absolute position ± 2 billion. Speed: .025 to 100 revolutions per second. Acceleration: 1 to 3,000 rev/sec/sec. Deceleration: 1 to 3,000 rev/sec/sec (set independently from acceleration). Time Delays: .01 to 300 seconds. Output Pulse Widths: 2 to 500 milliseconds. Iterations per loop: 1 to 65,535. Nested loops :50 Subroutine calls: 5 deep max
PHYSICAL	WEIGHT: 2 lb. 12 oz. AMBIENT TEMPERATURE: 0 to 40 deg C (32 to 104 deg F). HUMIDITY: Maximum of 90% non-condensing. CONNECTORS: Screw terminal connectors for input power, and motor, HD-15 for encoder/Hall signals. DB25 for signal and I/O. Si has DB25P for User I/O.

INPUTS AND OUTPUTS

DRIVE MODEL	TOTAL I/O	DEDICATED INPUTS*		GENERAL PURPOSE INPUTS	DEDICATED OUTPUTS**		GENERAL PURPOSE OUTPUTS
BLUAC5-S	7/3	6	Limit Switches (2), Alarm Reset, Servo Enable, Jog CW, CCW (2)	1	3	Alarm, Motion, Brake	0
BLUAC5-Q	7/3	6	Limit Switches (2), Alarm Reset, Servo Enable, Jog CW, CCW (2)	1	3	Alarm, Motion, Brake	0
BLUAC5-SI	15/7	4	Limit Switches (2), Jog CW, CCW (2)	11	3	Alarm, Motion, Brake	4

Sold & Serviced By:



Note 1: Unlabeled I/O points can be used as General purpose when dedicated function is not needed.

Note 2: I/O Expansion providing 8 additional inputs and 4 additional outputs can be added to both "S" and "Q" versions.

Note 3: Encoder Index (Z channel) can be used as an additional input for homing if present.

Toll Free Phone (877) SERV099
Toll Free Fax (877) SERV099
www.electromate.com
sales@electromate.com



BLuDC4 - TORQUE CURVES

M030-103-3-000
Drive: BLuDC4 Series
Settings: 24 VDC, 2.8A cont, 6.9 A peak

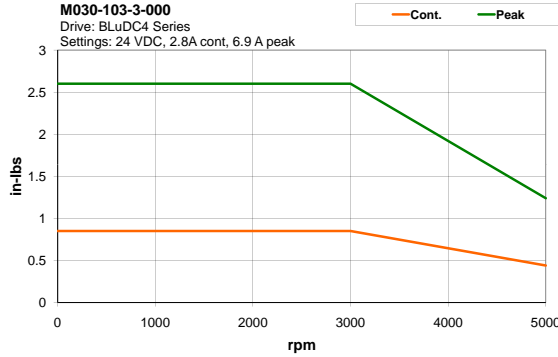

M0050-103-3-000
Drive: BLuDC4 Series
Settings: 24 VDC, 3.9A cont, 10.4A peak

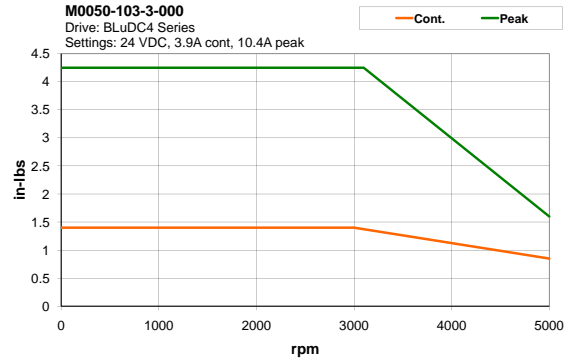

M0100-104-3-000
Drive: BLuDC 4 & 9 Series
Settings: 48 VDC, 3.7A cont, 10.4A peak

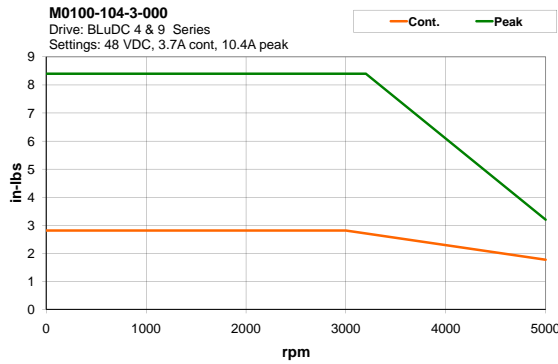

M0100-104-4-000
Drive: BLuDC 4 & 9 Series
Settings: 48 VDC, 3.7A cont, 10.4A peak

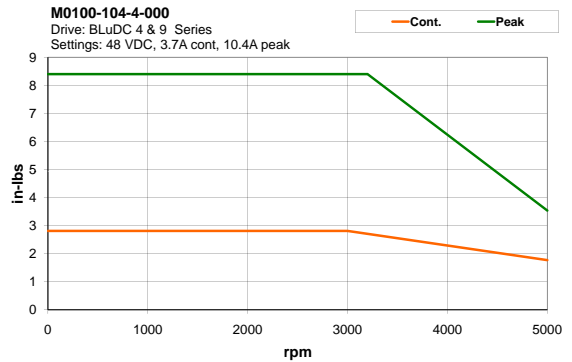

BLuDC9 - TORQUE CURVES

M0100-103-4-000
Drive: BLuDC9 Series
Settings: 24 VDC, 7.7A cont, 21.5 A peak

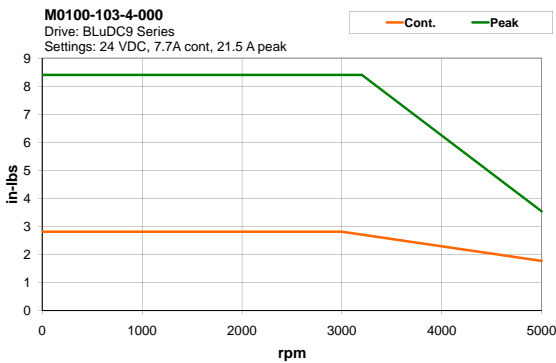

M0100-104-3-000
Drive: BLuDC 4 & 9 Series
Settings: 48 VDC, 3.7A cont, 10.4A peak

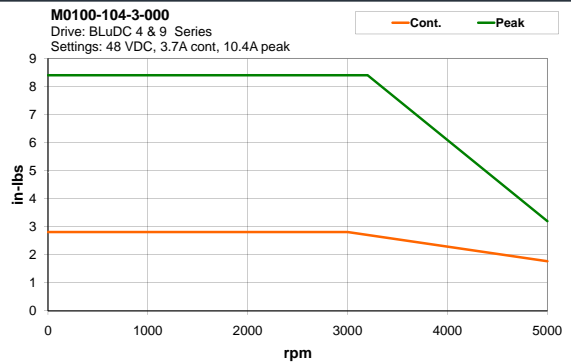

M0200-104-4-000
Drive: BLuDC9 series
Settings: 48VDC 6.4A/18A

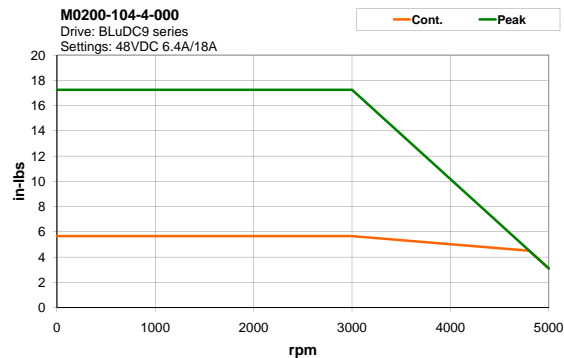

Sold & Serviced By:



Toll Free Phone (877) SERV098

Toll Free Fax (877) SERV099

www.electromate.com

sales@electromate.com

BLuAC5 - TORQUE CURVES

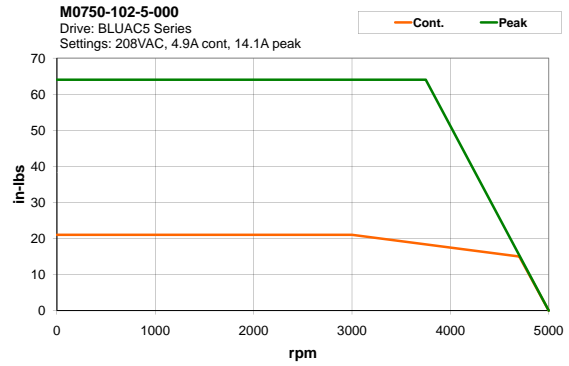
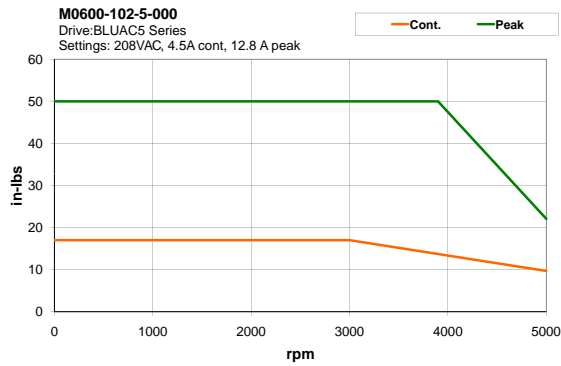
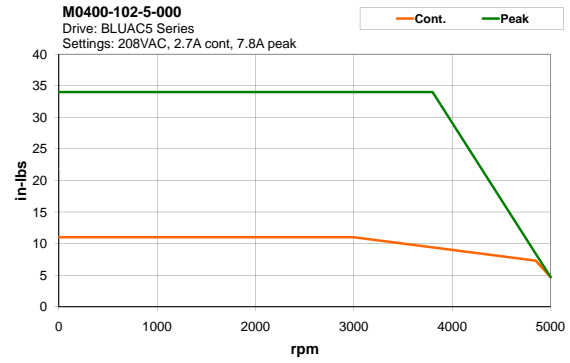
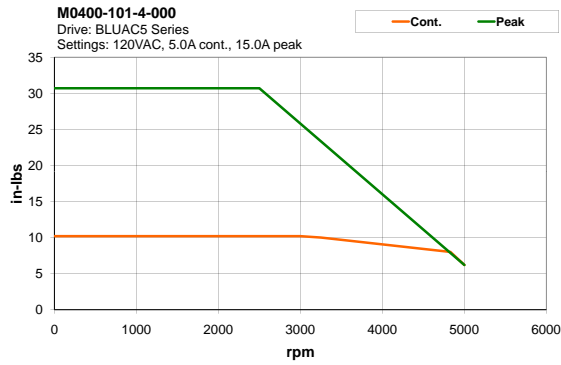

Sold & Serviced By:



Toll Free Phone (877) SERV098

Toll Free Fax (877) SERV099

www.electromate.com

sales@electromate.com



This page has been intentionally left blank

Sold & Serviced By:

 **ELECTROMATE**

Toll Free Phone (877) SERV098

Toll Free Fax (877) SERV099

www.electromate.com

sales@electromate.com

Servo Drive Accessories

RC-050 - REGENERATION CLAMP QUICKLINK: rc050

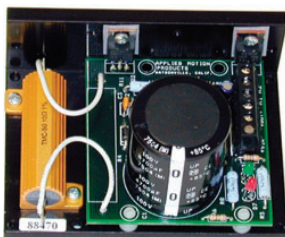

SPECIFICATIONS

Input Power -cont **50W**
 Input Power -peak **800w**
 Voltage range - **24-80VDC**

FEATURES

- Floating Voltage Threshold 24 TO 80VDC
- 50 W Power Dissipation
- Regen present LED
- Power LED
- Size; 3" x 4" x 2.25"

DESCRIPTION

Use when DC drives are controlling high inertia loads. Eliminates damaging bus "pump- up" by absorbing excess energy safely. Install between the drive and the power supply.

RA-100 - EXTERNAL REGENERATION RESISTOR QUICKLINK: ra100

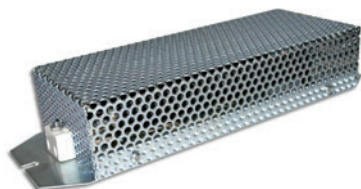

SPECIFICATIONS

Resistance **100 ohm**

FEATURES

- Power Rating 100W

DESCRIPTION

For use in systems with large inertia loads generating high regeneration voltages.

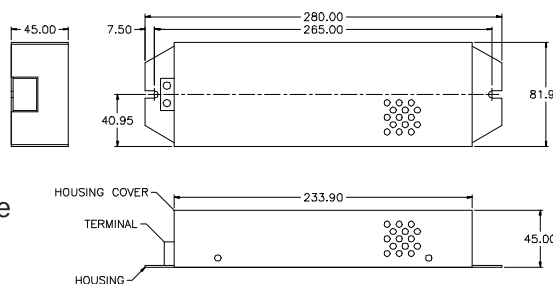

BOB1/BOB2 QUICKLINK: bob



FEATURES

- Break out 25 Pin 'D' Connectors to screw terminals

INCLUDES

- 3' cable

DESCRIPTION

For use in prototyping systems or for users who want the ability to change connections, The BOB units take the D type connections and spread them out to screw terminals.

Sold & Serviced By:



Toll Free Phone (877) SERV098
 Toll Free Fax (877) SERV099
www.electromate.com
sales@electromate.com

Servo Cables

DRIVE SERIES	MOTOR CABLE W/O BRAKE	MOTOR CABLE W/BRAKE	FEEDBACK CABLE
BLuAC	BLuMTR-FA	BLuMTR-BK-FA	BLuENC-CA
BLuDC	BLuMTR-CA	BLuMTR-BK-CA	BLuENC-CA



BLuMTR-CA-xx / 3004-181-xx

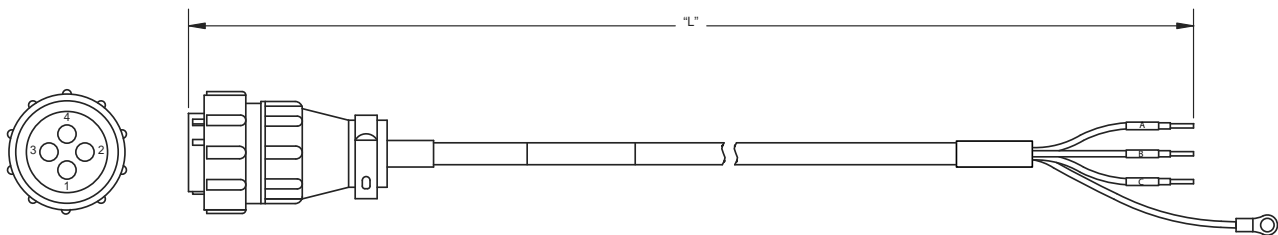

PIN #	LEAD COLOR	DIMENSION "L"	PART #
1	RED "A"	4 feet	BLuMTR-CA-04
2	WHITE "B"	10 feet	BLuMTR-CA-10
3	BLACK "C"	20 feet	BLuMTR-CA-20
4	GREEN/YELLOW (frame gnd/shield)		

BLuMTR-BK-CA-xx / 3004-183-xx

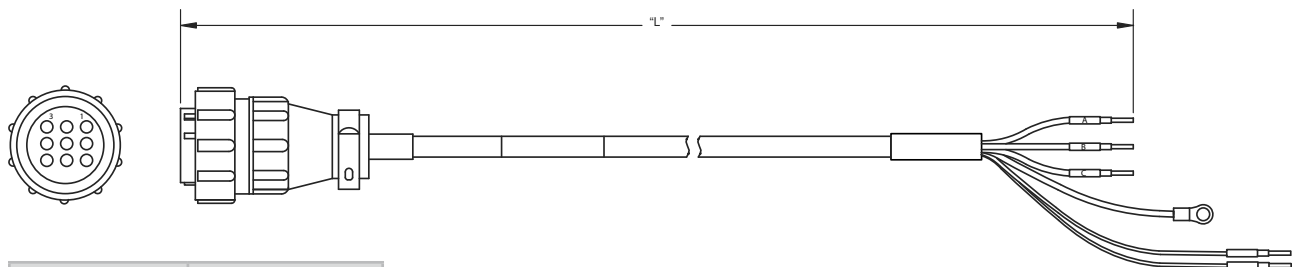

DIMENSION "L"	PART #
4 feet	BLuMTR-BK-CA-04
10 feet	BLuMTR-BK-CA-10
20 feet	BLuMTR-BK-CA-20

LEAD COLOR	RED "A"	WHITE "B"	BLACK "C"	GREEN/YELLOW (frame gnd/shield)	YELLOW "BRK"	BLUE "BRK"	N/C	N/C	N/C
PIN#	1	2	3	4	5	6	7	8	9

Sold & Serviced By:



Toll Free Phone (877) SERV098

Toll Free Fax (877) SERV099

www.electromate.com
sales@electromate.com

BLuENC-CA-xx / 3004-182-xx

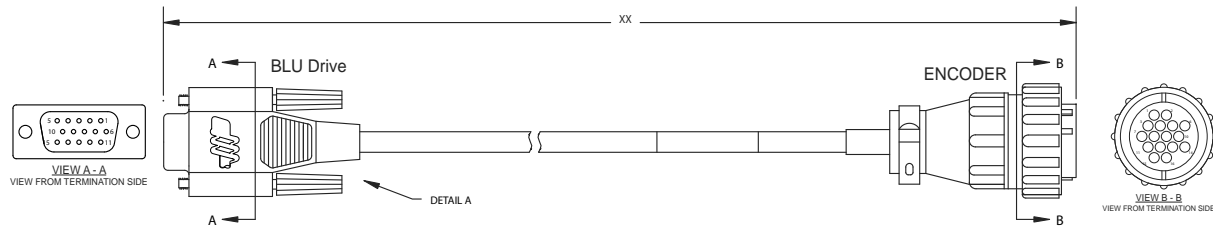

"XX"	PART #
4 feet	BLuENC-CA-04
10 feet	BLuENC-CA-10
20 feet	BLuENC-CA-20

PIN # TO ENCODER	1	2	3	4	5	6	7	8	9	10	11	12	13	14	15
PIN # TO BLU DRIVE	1	2	3	4	5	6	9	10	11	12	13	14	7	8	Housing
SIGNAL	A+	A-	B+	B-	Z+	Z-	HALL 1+	HALL 1-	HALL 2+	HALL 2-	HALL 3+	HALL 3-	+5V	0V	Shield

BLuMTR-FA-xx / 3004-197-xx

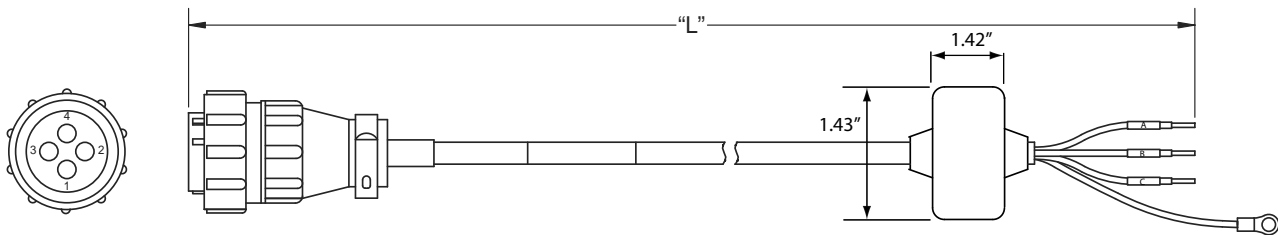

PIN #	LEAD COLOR
1	RED "A"
2	WHITE "B"
3	BLACK "C"
4	GREEN/YELLOW (frame gnd/shield)

DIMENSION "L"	PART #
4 feet	BLuMTR-FA-04
10 feet	BLuMTR-FA-10
20 feet	BLuMTR-FA-20

BLuMTR-BK-FA-xx / 3004-202-xx

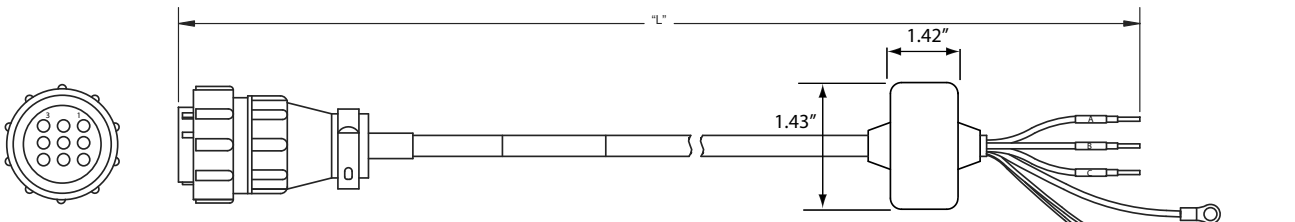

DIMENSION "L"	PART #
4 feet	BLuMTR-BK-FA-04
10 feet	BLuMTR-BK-FA-10
20 feet	BLuMTR-BK-FA-20

LEAD COLOR	RED	WHITE "B"	BLACK "C"	GREEN/YELLOW (frame gnd/shield)	YELLOW "BRK"	BLUE "BRK"	N/C	N/C	N/C
PIN #	1	2	3	4	5	6	7	8	9

Sold & Serviced By:



Toll Free Phone (877) SERV098

Toll Free Fax (877) SERV099

www.electromate.com

sales@electromate.com

This page has been intentionally left blank

Sold & Serviced By:

 **ELECTROMATE**

Toll Free Phone (877) SERV098

Toll Free Fax (877) SERV099

www.electromate.com

sales@electromate.com

Servo Motors



X0000-000-0-000

Series

- N = NEMA flange (IP65)
- M = Metric flange (IP65)
- A = Metric flange

Wattage Rating

- 0030 = 30 watts
- 0050 = 50 watts
- 0100 = 100 watts
- 0200 = 200 watts
- 0400 = 400 watts
- 0600 = 600 watts
- 0750 = 750 watts
- 0800 = 800 watts
- 0950 = 950 watts
- 1000 = 1000 watts
- 1500 = 1500 watts

Feedback Type

- 1 = 2000 line inc. encoder*
- 2 = 2048 line inc. encoder

Call factory for other options

* = Standard Options

Voltage

- 1 = 100
- 2 = 200
- 3 = 24
- 4 = 48
- 5 = 60
- 6 = 80

Shaft Type

- 0 = round*
- 1 = one flat
- 2 = two flats
- 3 = keyway
- 4 = N/A
- 5 = brake option w/round shaft*
- 6 = brake option w/one flat
- 7 = brake option w/two flats
- 8 = brake option w/keyway

Custom Features/Opt. Gearhead

Frame Size

- 2 = 28 mm
- 3 = 40 mm
- 4 = 60 mm
- 5 = 80 mm
- 6 = 86mm
- 7 = 100mm
- A = NEMA 17
- B = NEMA 23
- C = NEMA 34

EXAMPLE:

M0600-102-5-000

2,000 line (8000 count) encoder - 80 mm frame
Round shaft
600 watts
200 volts

Sold & Serviced By:

 **ELECTROMATE**

Toll Free Phone (877) SERV098

Toll Free Fax (877) SERV099

www.electromate.com

sales@electromate.com

N Series NEMA 17

QUICKLINK: n_nema17

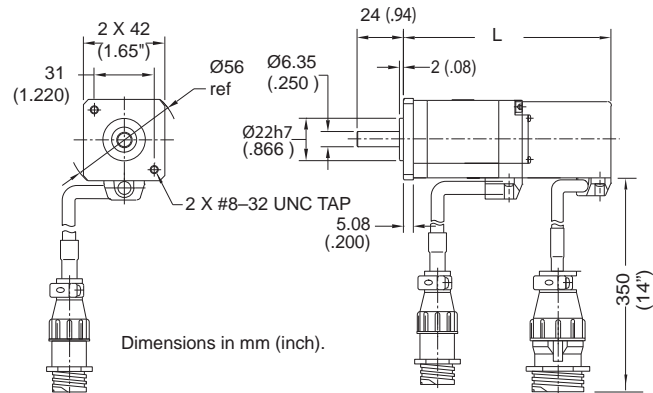

- 1) ratings are at 40°C with aluminum mounting plate 200mm x 200mm x 6mm
- 2) motors offered as standard with 2000 line incremental encoder - call for other options
- 3) refer to page 88 for cables
- 4) see page 102 for explanation of E.D.C.M.
- 5) full CAD drawings and 3D models are available on our website.

	PART NUMBER	L MM (INCH)
WITHOUT BRAKE	N0030-103-A-000	85.1 (3.35)
	N0050-103-A-000	91.1 (3.59)
	N0100-103-A-000	105 (4.13)
	N0100-101-A-000	105 (4.13)
WITH BRAKE	N0030-153-A-000	121 (4.76)
	N0050-153-A-000	128 (5.03)
	N0100-153-A-000	141 (5.55)
	N0100-151-A-000	141 (5.55)

PART NO.		N0030-103-A-000	N0050-103-A-000	N0100-103-A-000	N0100-101-A-000
POWER SUPPLY	V	24	24	24	100
RATED OUTPUT (PR)	W	30	50	100	100
RATED TORQUE (TR)	N.M	0.095	0.159	0.318	0.318
	LB.IN	0.85	1.4	2.81	2.81
PEAK TORQUE (TP)	N.M	0.29	0.48	0.95	0.95
	LB.IN	2.56	4.25	8.4	8.4
RATED SPEED	R/MIN	3000			
MAXIMUM SPEED	R/MIN	5000			
RATED ARMATURE CURRENT OF E.D.C.M.	A RMS	2.8	3.9	7.4	1.8
PEAK ARMATURE CURRENT OF E.D.C.M.	A RMS	6.9	10.4	21.0	5.3
TORQUE CONSTANT OF E.D.C.M.	N.M/A +/-10%	0.041	0.046	0.046	0.18
	LB.IN/A	0.36	0.4	0.4	1.6
VOLTAGE CONSTANT OF E.D.C.M.	V/(R/MIN)+/-10%	4.3x10 ⁻³	4.8x10 ⁻³	4.8x10 ⁻³	19.3x10 ⁻³
RESISTANCE OF E.D.C.M.	OHM	1.8	1.0	0.46	6.7
INDUCTANCE OF E.D.C.M.	MH	1.6	1.1	0.64	11
ROTOR MOMENT OF INERTIA	KGM ² X10 ⁻⁴	0.01	0.02	0.03	0.03
	G-CM ²	10	20	30	30
	OZ-IN-SEC ²	1.42x10 ⁻⁴	2.8x10 ⁻⁴	4.25x10 ⁻⁴	4.25x10 ⁻⁴
MAXIMUM RADIAL SHAFT LOAD	N	78.4			
	LBF	17			
MAXIMUM SHAFT THRUST LOAD	N	39.2			
	LBF	8.8			
	KG LB	0.2 0.44	0.4 0.88	0.5 1.1	0.5 1.1

Sold & Serviced By:

 **ELECTROMATE**

Toll Free Phone (877) SERV098

Toll Free Fax (877) SERV099

www.electromate.com

sales@electromate.com

N Series NEMA 23

QUICKLINK: n_nema23

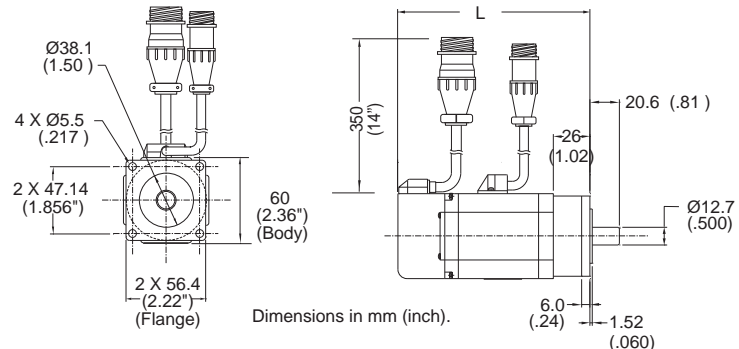
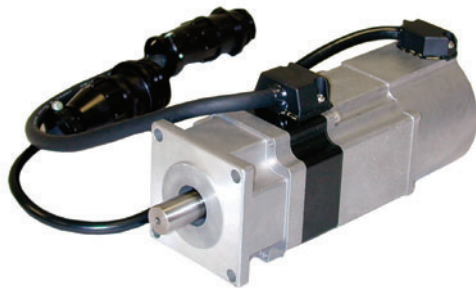

- 1) ratings are at 40°C with aluminum mounting plate 305mm x 305mm x 12mm
- 2) motors offered as standard with 2000 line incremental encoder - call for other options
- 3) refer to page 88 for cables
- 4) see page 102 for explanation of EDCM
- 5) full CAD drawings and 3D models are available on our website.

	PART NUMBER	L MM (INCH)
WITHOUT BRAKE	N0100-103-B-000	116 (4.56)
	N0100-101-B-000	116 (4.96)
	N0200-104-B-000	126 (4.96)
	N0200-101-B-000	126 (4.96)
	N0400-105-B-000	149 (5.86)
	N0400-101-B-000	149 (5.86)
WITH BRAKE	N0100-153-B-000	149 (5.87)
	N0100-151-B-000	149 (5.87)
	N0200-154-B-000	161 (6.33)
	N0200-151-B-000	161 (6.33)
	N0400-155-B-000	183 (7.2)
	N0400-151-B-000	183 (7.2)

PART NO.		N0100-103-B-000	N0100-101-B-000	N0200-104-B-000	N0200-101-B-000	N0400-105-B-000	N0400-101-B-000
POWER SUPPLY	V	24	100	48	100	60	100
RATED OUTPUT (PR)	W	100	100	200	200	400	400
RATED TORQUE (TR)	N.M	0.318	0.318	0.64	0.64	1.27	1.27
	LB.IN	2.81	2.81	5.66	5.66	11.2	11.2
PEAK TORQUE (TP)	N.M	0.95	0.95	1.91	1.91	3.82	3.82
		8.4	8.4	17.25	17.25	33.8	33.8
RATED SPEED	R/MIN	3000					
MAXIMUM SPEED	R/MIN	5000					
RATED ARMATURE CURRENT OF E.D.C.M	A RMS	7.7	1.8	6.4	3.5	8.2	5.6
PEAK ARMATURE CURRENT OF E.D.C.M	A RMS	21.5	5.0	18.0	10.0	23.8	16.3
TORQUE CONSTANT OF E.D.C.M.	N.M/A +/-10%	0.044	0.19	0.106	0.2	0.16	0.24
	LB.IN/A	0.39	1.68	0.93	1.77	1.41	2.12
VOLTAGE CONSTANT OF E.D.C.M.	V/(R/MIN)+/-	4.6x10 ⁻³	19.9x10 ⁻³	11x10 ⁻³	20.5x10 ⁻³	16.8x10 ⁻³	24.8x10 ⁻³
RESISTANCE OF E.D.C.M.	OHM	0.26	5.0	0.6	1.8	0.51	1.2
INDUCTANCE OF E.D.C.M.	MH	0.67	13	1.7	5.9	1.83	4.0
ROTOR MOMENT OF INERTIA	KGM ² X10 ⁻⁴	0.09	0.09	0.18	0.18	0.34	0.34
	G-CM ²	90	90	180	180	340	340
	OZ-IN-SEC ²	1.27x10 ⁻³	1.27x10 ⁻³	2.5x10 ⁻³	2.5x10 ⁻³	4.7x10 ⁻³	4.7x10 ⁻³
MAXIMUM RADIAL SHAFT LOAD	N	78.4		196		196	
	LBF	17		44		44	
MAXIMUM SHAFT THRUST LOAD	N	39.2		68.6		68.6	
	LBF	8.8		15.4		15.4	
MASS	KG LB	0.6 1.32	0.6 1.32	0.9 2.0	0.9 2.0	1.3 2.9	1.3 2.9

Sold & Serviced By:

 **ELECTROMATE**
MAXIMUM SHAFT THRUST LOAD

Toll Free Phone (877) SERV098

Toll Free Fax (877) SERV099

www.electromate.com

sales@electromate.com

N Series NEMA 34

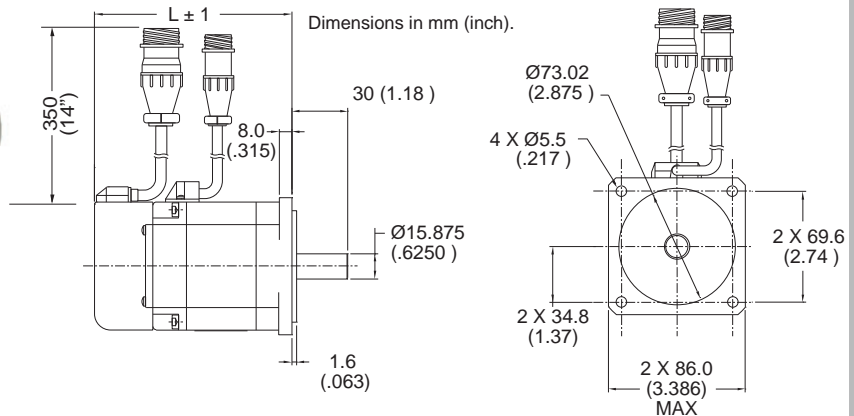
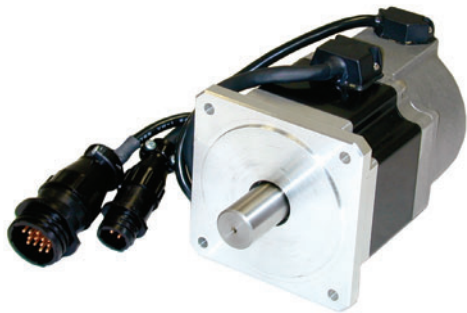
QUICKLINK: n_nema34

- 1) ratings are at 40°C with aluminum mounting plate 305mm x 305mm x 12mm
- 2) motors offered as standard with 2000 line incremental encoder - call for other options
- 3) refer to page 88 for cables
- 4) see page 102 for explanation of E.D.C.M.
- 5) full CAD drawings and 3D models are available on our website.

	PART NUMBER	L MM (INCH)
WITHOUT BRAKE	N0200-101-C-000	107 (4.21)
	N0400-102-C-000	120 (4.72)
	N0600-102-C-000	132 (5.19)
	N0750-102-C-000	140 (5.51)
WITH BRAKE	N0200-151-C-000	143.6 (5.65)
	N0400-152-C-000	155.6 (6.13)
	N0600-152-C-000	167.6 (6.60)
	N0750-152-C-000	176.6 (6.95)

PART NO.		N0200-101-C-000	N0400-102-C-000	N0600-102-C-000	N0750-102-C-000
POWER SUPPLY	V	100	200	200	200
RATED OUTPUT (PR)	W	200	400	600	750
RATED TORQUE (TR)	N.M	0.64	1.27	1.91	2.39
	LB.IN	5.6	11.2	16.9	21
PEAK TORQUE (TP)	N.M	1.91	3.82	5.73	7.16
	LB.IN	17	34	50	64
RATED SPEED	R/MIN	3000			
MAXIMUM SPEED	R/MIN	5000			
RATED ARMATURE CURRENT OF E.D.C.M	A RMS	3.0	2.8	4.4	5.0
PEAK ARMATURE CURRENT OF E.D.C.M	A RMS	8.6	8.0	12.9	14.5
TORQUE CONSTANT OF E.D.C.M	N.M/A +/-10%	0.23	0.49	0.45	0.5
	LB.IN/A	2	4.3	4.0	4.4
VOLTAGE CONSTANT OF E.D.C.M	V/(R/MIN)+/-10%	23.7 x 10 ⁻³	50.8 x 10 ⁻³	47 x 10 ⁻³	52.2 x 10 ⁻³
RESISTANCE OF E.D.C.M	OHM	1.8	2.7	1.3	1.3
INDUCTANCE OF E.D.C.M	MH	5.8	13.0	7.8	6.3
ROTOR MOMENT OF INERTIA	KGM ² X 10 ⁻⁴	0.3	0.56	0.98	1.08
	G-CM ²	300	560	980	1080
	OZ-IN-SEC ²	4.23 x 10 ⁻³	7.9 x 10 ⁻³	13.8 x 10 ⁻³	15.2 x 10 ⁻³
MAXIMUM RADIAL SHAFT LOAD	N	196		343	
	LBF	44		77	
MAXIMUM SHAFT THRUST LOAD	N	68.6		98	
	LBF	15.4		22	
MASS	KG LB	1.1 2.42	1.6 3.52	2.2 4.84	2.5 5.5

Sold & Serviced By:



Toll Free Phone (877) SERV098

Toll Free Fax (877) SERV098

www.electromate.com
sales@electromate.com

M Series 40 mm

QUICKLINK: m_40mm

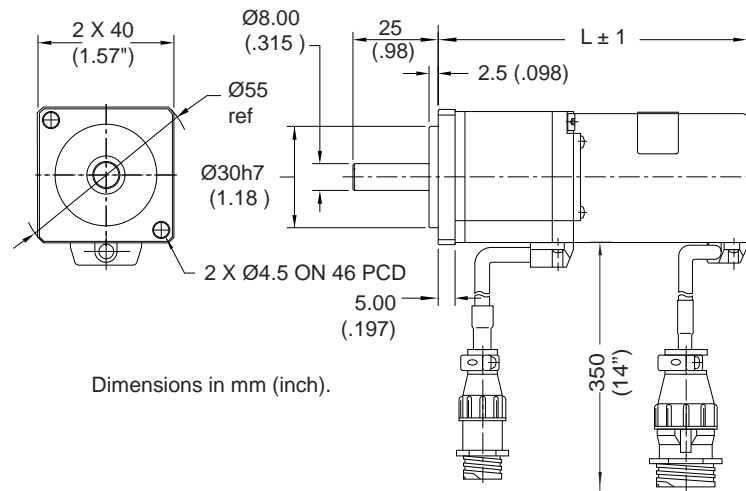

Dimensions in mm (inch).

- 1) ratings are at 40°C with aluminum mounting plate 200mm x 200mm x 6mm
- 2) motors offered as standard with 2000 line incremental encoder - call for other options
- 3) refer to page 88 for cables
- 4) see page 102 for explanation of E.D.C.M.
- 5) full CAD drawings and 3D models are available on our website.

	PART NUMBER	L MM (INCH)
WITHOUT BRAKE	M0030-103-3-000	81 (3.18)
	M0050-103-3-000	86.1 (3.38)
	M0100-103-3-000	101 (3.79)
	M0100-101-3-000	101 (3.97)
WITH BRAKE	M0030-153-3-000	115.7 (4.55)
	M0050-153-3-000	123 (4.84)
	M0100-153-3-000	136 (5.35)
	M0100-151-3-000	136 (5.35)

PART NO.		M0030-103-3-000	M0050-103-3-000	M0100-103-3-000	M0100-101-3-000
POWER SUPPLY	V	24	24	24	100
RATED OUTPUT (PR)	W	30	50	100	100
RATED TORQUE (TR)	N.M	0.095	0.159	0.318	0.318
	LB.IN	0.85	1.4	2.81	2.81
PEAK TORQUE (TP)	N.M	0.29	0.48	0.95	0.95
	LB.IN	2.56	4.25	8.4	8.4
RATED SPEED	R/MIN	3000			
MAXIMUM SPEED	R/MIN	5000			
RATED ARMATURE CURRENT OF E.D.C.M	A RMS	2.8	3.9	7.4	1.8
PEAK ARMATURE CURRENT OF E.D.C.M	A RMS	6.9	10.4	21.0	5.3
TORQUE CONSTANT OF E.D.C.M	N.M/A +/-10%	0.041	0.046	0.046	0.18
	LB.IN/A	0.36	0.4	0.4	1.6
VOLTAGE CONSTANT OF E.D.C.M	V/(R/MIN)+/-10%	4.3×10^{-3}	4.8×10^{-3}	4.8×10^{-3}	19.3×10^{-3}
RESISTANCE OF E.D.C.M	OHM	1.8	1.0	0.46	6.7
INDUCTANCE OF E.D.C.M	MH	1.6	1.1	0.64	11
ROTOR MOMENT OF INERTIA	KGM ² X10 ⁻⁴	0.01	0.02	0.03	0.03
	G-CM ²	10	20	30	30
	OZ-IN-SEC ²	1.42×10^{-4}	2.8×10^{-4}	4.25×10^{-4}	4.25×10^{-4}
MAXIMUM RADIAL SHAFT LOAD	N	78.4			
	LBF	17			
MAXIMUM SHAFT THRUST LOAD	N	39.2			
	LBF	8.8			
	KG LB	0.2 0.44	0.4 0.88	0.5 1.1	0.5 1.1

Sold & Serviced By:

 **ELECTROMATE**

MAXIMUM SHAFT THRUST LOAD

Toll Free Phone (877) SERV098

Toll Free Fax (877) SERV099^{MASS}

www.electromate.com

sales@electromate.com

M Series 60mm Motors

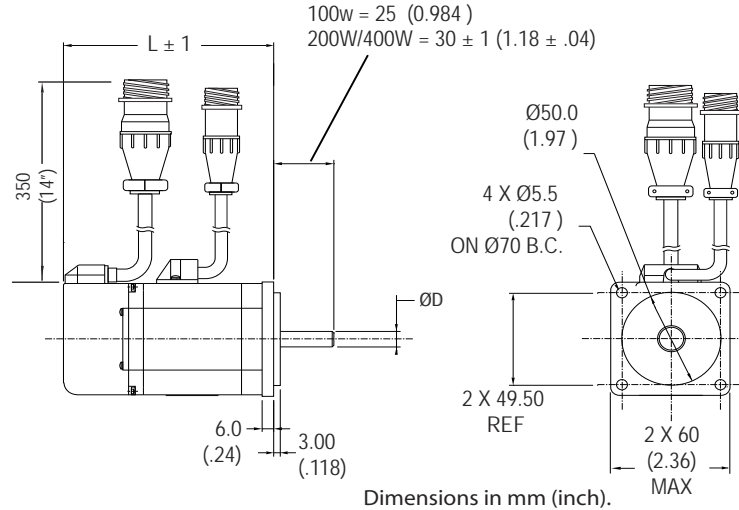
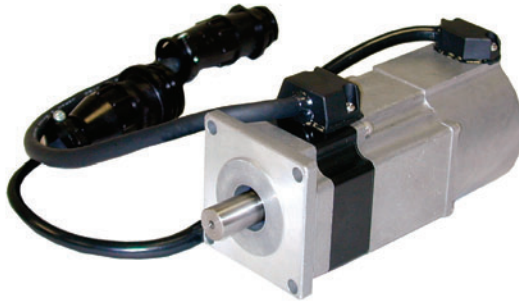
QUICKLINK: m_60mm

- 1) ratings are at 40°C with aluminum mounting plate 305mm x 305mm x 12mm.
- 2) motors offered as standard with 2000 line incremental encoder - call for other options.
- 3) refer to page 88 for cables
- 4) see page 102 for explanation of E.D.C.M.
- 5) full CAD drawings and 3D models are available on our website.

	PART NUMBER	L MM (INCH)	D MM (INCH)
WITHOUT BRAKE	M0100-103-4-000	87 (3.42)	8 (0.314)
	M0100-101-4-000	87 (3.42)	8 (0.314)
	M0200-104-4-000	103 (4.05)	14 (0.551)
	M0200-101-4-000	103 (4.05)	14 (0.551)
	M0400-105-4-000	126 (4.96)	14 (0.551)
	M0400-101-4-000	126 (4.96)	14 (0.551)
WITH BRAKE	M0100-153-4-000	110 (4.33)	8 (0.314)
	M0100-151-4-000	110 (4.33)	8 (0.314)
	M0200-154-4-000	135 (5.31)	14 (0.551)
	M0200-151-4-000	135 (5.31)	14 (0.551)
	M0400-155-4-000	160 (6.3)	14 (0.551)
	M0400-151-4-000	160 (6.3)	14 (0.551)

PART NO.		M0100-103-4-000	M0100-101-4-000	M0200-104-4-000	M0200-101-4-000	M0400-105-4-000	M0400-101-4-000
POWER SUPPLY	V	24	100	48	100	60	100
RATED OUTPUT (PR)	W	100	100	200	200	400	400
RATED TORQUE (TR)	N.M	0.318	0.318	0.64	0.64	1.27	1.27
	LB.IN	2.81	2.81	5.66	5.66	11.2	11.2
PEAK TORQUE (TP)	N.M	0.95	0.95	1.91	1.91	3.82	3.82
	LB.IN	8.4	8.4	17.25	17.25	33.8	33.8
RATED SPEED	R/MIN	3000		3000		3000	
MAXIMUM SPEED	R/MIN	5000		5000		5000	
RATED ARMATURE CURRENT OF E.D.C.M	A RMS	7.7	1.8	6.4	3.5	8.2	5.6
PEAK ARMATURE CURRENT OF E.D.C.M	A RMS	21.5	5.0	18.0	10.0	23.8	16.3
TORQUE CONSTANT OF E.D.C.M	N.M/A +/-10%	0.044	0.19	0.106	0.2	0.16	0.24
	LB.IN/A	0.39	1.68	0.93	1.77	1.41	2.12
VOLTAGE CONSTANT OF E.D.C.M	V/(R/MIN)+/-10%	4.6 x 10 ⁻³	19.9 x 10 ⁻³	11 x 10 ⁻³	20.5 x 10 ⁻³	16.8 x 10 ⁻³	24.8 x 10 ⁻³
RESISTANCE OF E.D.C.M	OHM	0.26	5.0	0.6	1.8	0.51	1.2
INDUCTANCE OF E.D.C.M	MH	0.67	13	1.7	5.9	1.83	4.0
ROTOR MOMENT OF INERTIA	KGM ² X10 ⁻⁴	0.09	0.09	0.18	0.18	0.34	0.34
	G-CM ²	90	90	180	180	340	340
	OZ-IN-SEC ²	1.27 x 10 ⁻³	1.27 x 10 ⁻³	2.5 x 10 ⁻³	2.5 x 10 ⁻³	4.7 x 10 ⁻³	4.7 x 10 ⁻³
MAXIMUM RADIAL SHAFT LOAD	N	78.6		196		196	
	LBF	17		44		44	
MAXIMUM SHAFT THRUST LOAD	N	39.2		68.6		68.6	
	LBF	8.8		15.4		15.4	
MASS	KG LB	0.6 1.32	0.6 1.32	0.9 2.0	0.9 2.0	1.3 2.9	1.3 2.9

Sold & Serviced By:



Toll Free Phone (877) SERV098

Toll Free Fax (877) SERV099

www.electromate.com
sales@electromate.com

M Series 80mm Motors

QUICKLINK: m_80mm

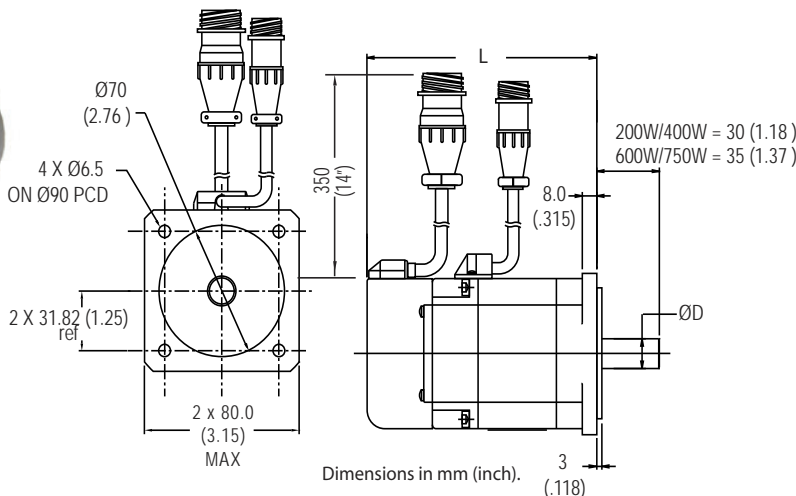

- 1) ratings are at 40°C with aluminum mounting plate 305mm x 305mm x 12mm.
- 2) motors offered as standard with 2000 line incremental encoder - call for other options
- 3) refer to page 88 for cables.
- 4) see page 102 for explanation of E.D.C.M.
- 5) full CAD drawings and 3D models are available on our website.

	PART NUMBER	L MM (INCH)	D MM (INCH)
WITHOUT BRAKE	M0200-101-5-000	90 (3.54)	14 (0.551)
	M0400-102-5-000	103 (4.05)	14 (0.551)
	M0600-102-5-000	127 (5.0)	19 (0.748)
	M0750-102-5-000	135 (5.31)	19 (0.748)
WITH BRAKE	M0200-151-5-000	121.6 (4.78)	14 (0.551)
	M0400-152-5-000	133.6 (5.25)	14 (0.551)
	M0600-152-5-000	164 (6.45)	19 (0.748)
	M0750-152-5-000	176.6 (6.95)	19 (0.748)

PART NO.		M0200-101-5-000	M0400-102-5-000	M0600-102-5-000	M0750-102-5-000
POWER SUPPLY	V	100	200	200	200
RATED OUTPUT (PR)	W	200	400	600	750
RATED TORQUE (TR)	N.M	0.64	1.27	1.91	2.39
	LB.IN	5.6	11	16.9	21
PEAK TORQUE (TP)	N.M	1.91	3.82	5.73	7.16
	LB.IN	17	34	50	64
RATED SPEED	R/MIN	3000			
MAXIMUM SPEED	R/MIN	5000			
RATED ARMATURE CURRENT OF E.D.C.M	A RMS	3.0	2.8	4.4	5.0
PEAK ARMATURE CURRENT OF E.D.C.M	A RMS	8.6	8.0	12.9	14.5
TORQUE CONSTANT OF E.D.C.M	N.M/A +/-10%	0.23	0.49	0.45	0.5
	LB.IN/A	2	4.3	4.0	4.4
VOLTAGE CONSTANT OF E.D.C.M	V/(R/MIN)+/-10%	23.7 x 10 ⁻³	50.8 x 10 ⁻³	47 x 10 ⁻³	52.2 x 10 ⁻³
RESISTANCE OF E.D.C.M	OHM	1.8	2.7	1.3	1.3
INDUCTANCE OF E.D.C.M	MH	5.8	13.0	7.8	6.3
ROTOR MOMENT OF INERTIA	KGM ² X10 ⁻⁴	0.3	0.56	0.98	1.08
	G-CM ²	300	560	980	1080
	OZ-IN-SEC ²	4.23 x 10 ⁻³	7.9 x 10 ⁻³	13.8 x 10 ⁻³	15.2 x 10 ⁻³
MAXIMUM RADIAL SHAFT LOAD	N	196		343	
	LBF	44		77	
MAXIMUM SHAFT THRUST LOAD	N	68.6		98	
	LBF	15.4		22	
MASS	KG LB	1.1 2.42	1.6 3.52	2.2 4.84	2.5 5.5

Sold & Serviced By:



Toll Free Phone (877) SERV098

Toll Free Fax (877) SERV098

www.electromate.com

sales@electromate.com

M Series 100mm Motors

QUICKLINK: m_100mm

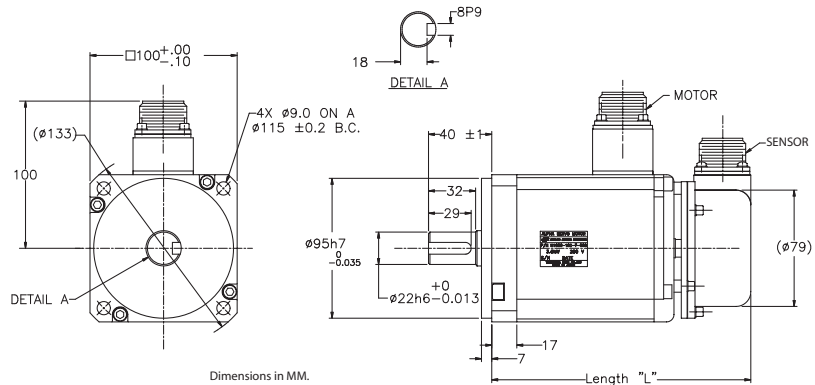
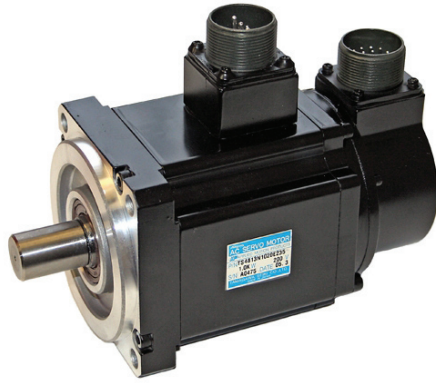

Dimensions in MM.

ENCODER CONNECTION			
PIN	FUNCTION	PIN	FUNCTION
A	DATA A+	K	HALL 2+
B	DATA A-	L	HALL 2-
C	DATA B+	M	HALL 3+
D	DATA B-	N	SHIELD
E	N/C	P	N/C
F	INDEX Z-	R	OV
G	INDEX Z+	S	+5V
H	HALL 1+	T	HALL 3-
J	HALL 1-		

MOTOR CONNECTION			
PIN	FUNCTION	PIN	FUNCTION
A	N/C		
B	C (W)		
C	SENS1		
D	SENS2		
E	CASE G.		
F	A (U)		
G	N/C		
H	N/C		
I	B (V)		

MOTOR MS3102A20-18P



SENSOR 97F3102A20-29P



- 1) ratings are at 40°C with aluminum mounting plate 450mm x 450mm x 25mm.
- 2) motors offered as standard with 2048 line incremental encoder - call for other options.
- 3) See page 102 for explanation of E.D.C.M.

	PART NUMBER	L MM (INCH)
WITHOUT BRAKE	M1000-232-7-000	158mm (6.22")
	M1500-232-7-000	190mm (7.48")
WITH BRAKE	M1000-282-7-000	176mm (6.93")
	M1500-282-7-000	208mm (8.19")

PART NO.		M1000-232-7-000	M1500-232-7-000
POWER SUPPLY	V	200	200
RATED OUTPUT (PR)	W	1000	1500
RATED TORQUE (TR)	N.M	3.3	4.8
	LB.IN	29.2	42
PEAK TORQUE (TP)	N.M	9.9	14.3
	LB.IN	87	126
RATED SPEED	R/MIN	3000	
MAXIMUM SPEED	R/MIN	4500	
RATED ARMATURE CURRENT OF E.D.C.M	A RMS	6.8	9.5
PEAK ARMATURE CURRENT OF E.D.C.M	A RMS	18.7	26.7
TORQUE CONSTANT OF E.D.C.M	N.M/A +/-10%	0.56	0.56
	LB.IN/A	4.9	4.9
VOLTAGE CONSTANT OF E.D.C.M	V/(R/MIN)+/-10%	58.4 x 10 ⁻³	58.5 x 10 ⁻³
RESISTANCE OF E.D.C.M	OHM	2.05	1.02
INDUCTANCE OF E.D.C.M	MH	8.4	4.7
ROTOR MOMENT OF INERTIA	KGM ² X10 ⁻⁴	2.6	3.6
	G-CM ²	2600	3600
	OZ-IN-SEC ²	36 x 10 ⁻³	51 x 10 ⁻³
MAXIMUM RADIAL SHAFT LOAD	N	490	
	LBF	110	
MAXIMUM SHAFT THRUST LOAD	N	98	
	LBF	22	
MASS	KG LB	4.7 10.4	5.7 12.5

Sold & Serviced By:



Toll Free Phone (877) SERV098

Toll Free Fax (877) SERV099

www.electromate.com

sales@electromate.com

A Series 80 mm Motors

QUICKLINK: a_80mm

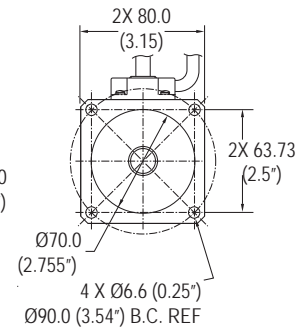
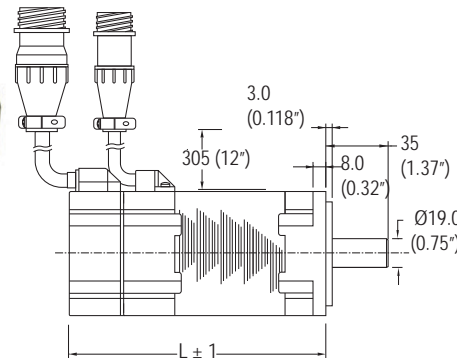
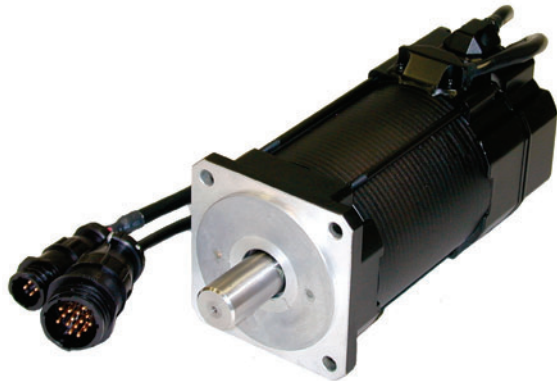

Dimensions in mm (inch) .

- 1) ratings are at 40°C with aluminum mounting plate 305mm x 305mm x 12mm.
- 2) motors offered as standard with 2000 line incremental encoder - call for other options.
- 3) refer to page 88 for cables.
- 4) see page 102 for explanation of E.D.C.M.
- 5) full CAD drawings are available on our website.

PART NUMBER	L MM (INCH)
A0600-102-5-000	128 (5.04)
A0800-102-5-000	145 (5.71)
A0950-102-5-000	160 (6.30)

PART NO.		A0600-102-5-000	A0800-102-5-000	A0950-102-5-000
POWER SUPPLY	V	200	200	200
RATED OUTPUT (PR)	W	600	800	950
RATED TORQUE (TR)	N.M	1.91	2.55	3.02
	LB.IN	16.9	22.57	26.75
PEAK TORQUE (TP)	N.M	5.73	7.64	9.06
	LB.IN	50.71	67.61	80.19
RATED SPEED	R/MIN	3000	3000	2000
MAXIMUM SPEED	R/MIN	5000	5000	2600
RATED ARMATURE CURRENT OF E.D.C.M.	A RMS	4.2	4.6	6.9
PEAK ARMATURE CURRENT OF E.D.C.M.	A RMS	12.6	13.8	19.5
TORQUE CONSTANT OF E.D.C.M.	N.M/A +/-10%	0.47	0.57	0.46
	LB.IN/A	4.16	5.05	4.07
VOLTAGE CONSTANT OF E.D.C.M.	V/(R/MIN)+/-10%	49x10 ⁻³	59.4x10 ⁻³	48.9x10 ⁻³
RESISTANCE OF E.D.C.M.	OHM	1.25	1.2	0.64
INDUCTANCE OF E.D.C.M.	MH	8.0	8.7	4.73
ROTOR MOMENT OF INERTIA	KGM ² X10 ⁻⁴	1.00	1.3	1.62
	G-CM ²	1000	1300	1620
	OZ-IN-SEC ²	1.42x10 ⁻²	1.84x10 ⁻²	2.29x10 ⁻²
MAXIMUM RADIAL SHAFT LOAD	N		343	
	LBF		77	
MAXIMUM SHAFT THRUST LOAD	N		98	
	LBF		22	
	KG LB	2.6 5.73	3.2 7.04	3.79 8.36

Sold & Serviced By:

 **ELECTROMATE**

Toll Free Phone (877) SERV098
Toll Free Fax (877) SERV099 MASS
www.electromate.com
sales@electromate.com

V Series Servo Motor

QUICKLINK: vseries

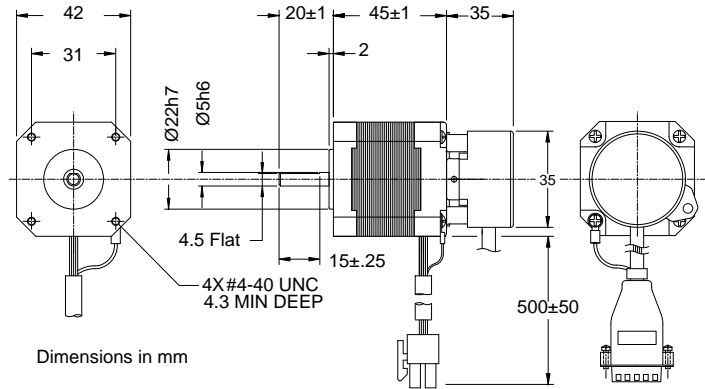
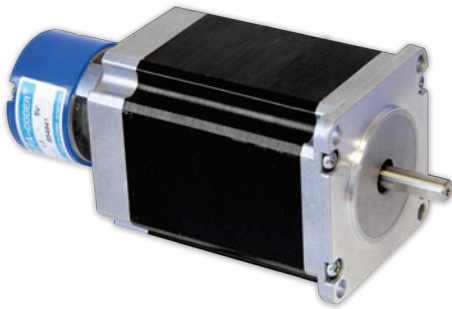

Dimensions in mm

- 1) ratings are at 40°C with aluminum mounting plate 305mm x 305mm x 12mm
- 2) Motors offered as standard with 2048 line incremental encoder - call for other options
- 3) see page 102 for explanation of E.D.C.M.
- 4) Full CAD drawings are available on our website.

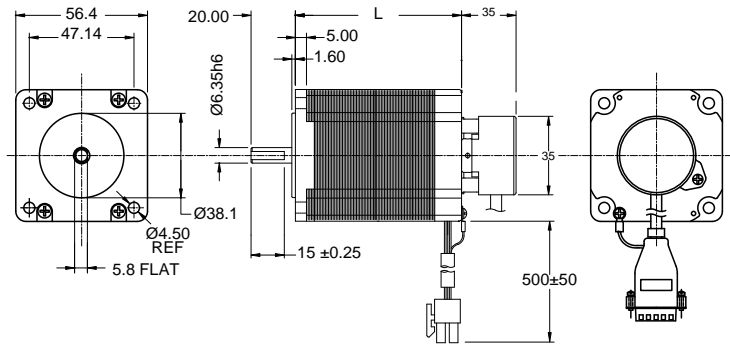

MODEL		NEMA 17		NEMA 23	
		V0050-214-A-000	V0100-214-B-000	V0200-214-B-000	V0250-214-B-000
LENGTH "L"	MM	45	52	78	104
RATED OUTPUT (PR)	W	50	100	200	200
POWER SUPPLY	V	48	48	48	48
RATED TORQUE (TR)	N.M	0.095	0.19	0.38	0.57
	LB.IN	0.84	1.68	3.36	5.0
PEAK TORQUE (TP)	N.M	0.29	0.57	1.15	1.72
	LB.IN	2.56	5.0	10.17	15.22
RATED SPEED	R/MIN	5000	5000	5000	3350
MAXIMUM SPEED	R/MIN	7320	7320	5900	4000
RATED ARMATURE CURRENT	A RMS	5.3	6.3	5.7	5.8
PEAK ARMATURE CURRENT	A RMS	15.2	17.7	16.5	17
TORQUE CONSTANT OF E.D.C.M	N.M/A ^{+/-10%}	0.019	0.03	0.07	0.1
	LB.IN/A	0.168	0.27	0.619	0.88
VOLTAGE CONSTANT OF E.D.C.M	V/(KR/MIN) ^{+/-10%}	2.00	3.5	7.4	10.7
ARMATURE RESISTANCE OF E.D.C.M	OHM ^{+/-10%}	0.45	0.45	0.6	0.89
ARMATURE INDUCTANCE OF E.D.C.M	MH ^{+/-30%}	0.8	1.6	3.0	4.2
ROTOR MOMENT OF INERTIA	KGM ² X10 ⁻⁴	0.039	0.103	0.192	0.27
	GM.CM ²	39	103	192	270
	OZ-IN-SEC ²	0.55x10 ⁻³	1.5x10 ⁻³	2.71x10 ⁻³	3.82x10 ⁻³
MAXIMUM RADIAL SHAFT LOAD	N	39.2		58.8	
	LBF	8.8		13.2	
MAXIMUM AXIAL THRUST LOAD	N	19.6		29.4	
	LBF	0.6		0.8	
MASS	KG LB	0.65 1.43	0.9 2.00	1.35 2.97	1.7 3.74

Sold & Serviced By:



Toll Free Phone (877) SERV098
 Toll Free Fax (877) SERV099
www.electromate.com
sales@electromate.com

Holding Brake Specifications

MOTOR POWER MOTOR FRAME SIZE		30W NEMA 17 40 MM	50W NEMA 17 40 MM	100W NEMA 17 40 MM	100W NEMA 23 60 MM	200W NEMA 23 60 MM	400W NEMA 23 60 MM	200W NEMA 34 80 MM	400W NEMA 34 80 MM	600W NEMA 34 80 MM	750W NEMA 34 80 MM
RATED VOLTAGE	V	24									
STATIC FRICTION TORQUE	Nm	0.32			1.27			2.55			
	lb-in	2.83			11.24			22.5			
INPUT POWER	W	5		9	9		9.5		9.5		
INPUT CURRENT	A	0.2		0.375	0.375		0.39		0.39		
ARMATURE RELEASE TIME	ms Max	20		20	20		50		50		
ARMATURE PULL IN TME	ms Max	40		40	50		80		80		

Motor Phase Excitation Sequence

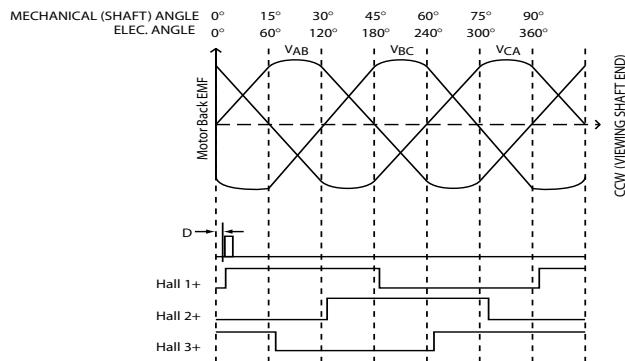

SHAFT LOCK

Motor shaft can be locked at 0° by applying the rated current + to terminal B and - to terminal A.

Encoder resolution 2,000 lines/rev.

Encoder Connections

ENCODER CONNECTION

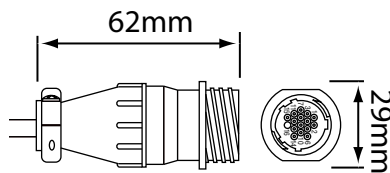

	CONNECTOR	MATING CONNECTOR
HOUSING	AMP# 206036-3	AMP# 206037-1
PINS	AMP# 1-66103-2 (15 pcs)	AMP# 1-66105-3 (15 pcs)
CABLE CLAMP	AMP# 206070-1	AMP# 206070-1

PIN NUMBER	FUNCTION	COLOR
1	A+	Blue
2	A-	Blue/black
3	B+	Green
4	B-	Green/black
5	Index Z+	Yellow
6	Index Z-	Yellow/black
7	Hall 1+	Brown
8	Hall 1-	Brown/black
9	Hall 2+	Grey
10	Hall 2-	Grey/black
11	Hall 3+	White
12	Hall 3-	White/black
13	+5V	Red
14	0V	Black
15	DRAIN	W/shrinktubing
16	N/C	N/c

Sold & Serviced By:

 **ELECTROMATE**

Toll Free Phone (877) SERV098

Toll Free Fax (877) SERV099

www.electromate.com

sales@electromate.com

Motor Connections

MOTOR WITHOUT BRAKE CONNECTION

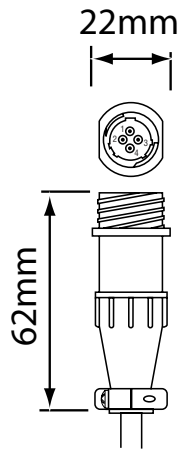

PIN NUMBER	FUNCTION	COLOR
1	A	RED
2	B	WHITE
3	C	BLACK
4	CASE GND	GREEN

	CONNECTOR	MATING CONNECTOR
HOUSING	AMP# 206153-1	AMP# 206060-1
PINS	AMP# 1-66099-4 (4 pcs)	AMP# 1-66101-4 (4 pcs)
CABLE CLAMP	AMP# 206062-3	AMP# 206062-3

MOTOR WITH BRAKE CONNECTION

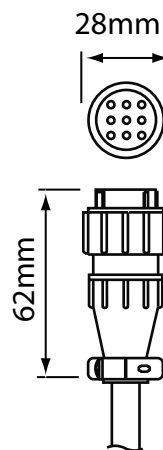

PIN NUMBER	FUNCTION	COLOR
1	A	RED
2	B	WHITE
3	C	BLACK
4	CASE GND	GREEN
5	BRAKE	YELLOW
6	BRAKE	BLUE
7		
8		
9		

	CONNECTOR	MATING CONNECTOR
HOUSING	AMP# 206705-2	AMP# 206708-1
PINS	AMP# 1-66099-4 (4 pcs) AMP# 1-66103-2 (2 pcs)	AMP# 66101-4 (4 pcs) AMP# 66105-3 (2 pcs)
CABLE CLAMP	AMP# 206966-1	AMP# 206963-1

E.D.C.M. Explanation

E.D.C.M.

Some values in this catalog are quoted in E.D.C.M (Equivalent DC Motor). The diagram below shows how these values are derived with respect to line to line values.

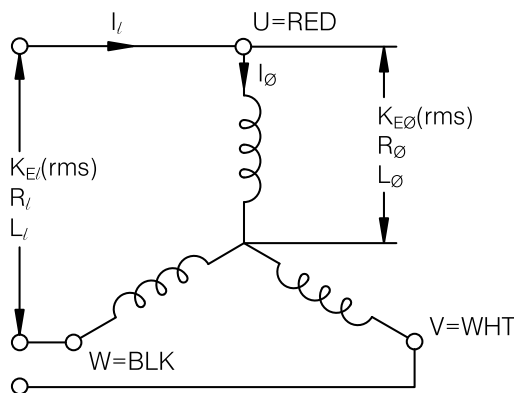

	E.D.C.M.	LINE	PHASE
CURRENT:	$I(rms)$	$= I_l(rms)$	$= I_ø(rms)$
VOLTAGE CONSTANT:	$K_E(rms)$	$= \sqrt{3} \times K_{E_l}(rms)$	$= 3 \times K_{E_ø}(rms)$
ARMATURE RESISTANCE:	R_a	$= 1.5 \times R_l$	$= 3 \times R_ø$
ARMATURE INDUCTANCE:	L_a	$= 1.5 \times L_l$	$= 3 \times L_ø$

Sold & Serviced By:

ELECTROMATE

Toll Free Phone (877) SERV098

Toll Free Fax (877) SERV099

www.electromate.com

sales@electromate.com

Gearheads

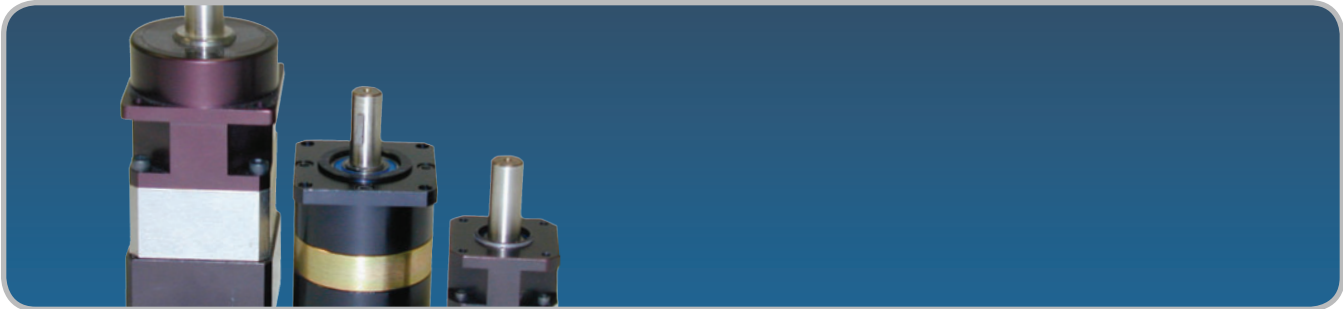

Many Servo and Stepper applications require the use of precision low backlash gearheads for inertia matching, speed matching, increased torque and increasing system resolution. Applied Motion offers a variety of units with different power outputs, backlash and ratios.

Sizes

- 17
- 23
- 34
- 42

Ratios

- 3:1 to 700:1

Custom and Right Angle versions available on request.

For full details on the ranges of gearheads offered by Applied Motion Products, please visit our website.

Sold & Serviced By:

 **ELECTROMATE**

Toll Free Phone (877) SERV098

Toll Free Fax (877) SERV099

www.electromate.com

sales@electromate.com

This page has been intentionally left blank

Sold & Serviced By:

 **ELECTROMATE**

Toll Free Phone (877) SERV098

Toll Free Fax (877) SERV099

www.electromate.com

sales@electromate.com

Glossary

ABSOLUTE POSITION

Position referenced to a fixed zero or datum position.

ABSOLUTE PROGRAMMING

A positioning coordinate reference wherein all positions are specified relative to some reference or "home" position. This is different from Incremental programming where distances are specified relative to the current position.

AMBIENT TEMPERATURE

The temperature of the medium immediately surrounding a device.

AMPLIFIER

Electronic device that converts command signals (analog or digital) to high power voltages and currents for the operation of the motor.

ASCII

American Standard Code for Information Interchange. This code assigns a number to each numeral and letter of the alphabet. In this manner, information can be transmitted between machines as a series of binary numbers.

AXIAL PLAY

The axial shaft displacement due to a reversal of an axial force on the shaft. (End play)

BAUD RATE

The number of binary bits transmitted per second for serial communications such as RS-232.

BI-LEVEL DRIVE (DUAL VOLTAGE DRIVE)

A driver where two levels of voltage are used to drive a step motor. A high (over drive) voltage is applied to the winding each time it is switched on. The high voltage stays on until the current reaches a predetermined level. The high voltage is turned off after a time period determined experimentally or by sensing winding current. The low voltage maintains the desired current.

BIPOLAR DRIVE

A drive which reverses the magnetic polarity of a pole by electronically switching the polarity of the current to the winding (+ or-). Bipolar drives can be used with 4,6, or 8 lead motors. With 4 and 8 lead motors, bipolar drives are usually more efficient than unipolar drives and generally produce more torque.

BRUSHLESS SERVO DRIVE

A servo drive used to control a permanent magnet synchronous AC motor.

CHOPPER DRIVE

A step motor drive that uses switching amplifiers to control motor current.

CLASS B INSULATION

Specifies motor insulation that is rated for operation of 130 degrees centigrade.

CLASS H INSULATION

Specifies motor insulation that is rated for operation of 180 degrees centigrade.

CLOSED LOOP

A system that uses some form of feedback device to monitor the system output. The signal from the device is used to correct any errors between actual and demanded output.

COGGING

Term used to describe uneven velocity in motors, usually at low speeds.

COMMUTATION

A term which refers to the action of steering currents or voltage to the proper motor phases to produce optimum motor torque. In brush type motors, commutation is done electromechanically via the brushes and commutator. In brushless motors, commutation is done by the switching electronics using rotor position information typically obtained from hall sensors, tachometer, resolver or encoder.

CONTROLLER (STEP MOTOR)

A system consisting of a DC power supply and power switches plus associated circuits to control the switches in the proper sequence.

DAMPING

An indication of the rate of decay of a signal to its steady state value. Related to settling time.

DEAD BAND

A range of input signals for which there is no system response.

DETENT TORQUE

The maximum torque required to slowly rotate a step motor shaft with no power applied to the windings. This applies only to permanent magnet or hybrid motors. The leads are separated from each other.

DRIVE (PWM)

A motor drive utilizing Pulse-Width Modulation techniques to control power to the motor. Typically a high efficiency drive that can be used for high response applications.

DRIVE (SERVO)

A motor drive which utilizes internal feedback loops for accurate control of motor and current and/or velocity.

DRIVE (STEPPER)

An electronic package to convert digital step and direction inputs to currents to drive a step motor.

DUTY CYCLE

The percentage of ON time vs. OFF time. A device that is always on has a 100% duty cycle. Half on and half off is a 50% duty cycle.

Sold & Serviced By:



Toll Free Phone (877) SERV098

Toll Free Fax (877) SERV099

www.electromate.com

sales@electromate.com



Glossary

DYNAMIC BRAKING

A passive technique for stopping a permanent magnet brush or brushless motor. The motor windings are shorted together through a resistor, which results in a motor braking with an exponential decrease in speed.

ENCODER

A device used to translate motion into electrical signals used to close the loop. Often used as a position/motion feedback device in closed loop systems.

ENCODER MARKER PULSE

A once-per-revolution signal that provided by some incremental encoders to specify a reference point within that revolution.

END PLAY

The axial shaft motion due to the reversal of an axial force acting on a shaft with axial clearance or low axial pre-load.

FOLLOWING ERROR

The positional error during motion between the loads actual position and the commanded position.

FRICITION COULOMB

A resistance to motion between non-lubricated surfaces. This force remains constant with velocity.

FRICITION VISCOUS

A resistance to motion between lubricated surfaces. This force is proportional to the relative velocity between the surfaces.

HALL SENSORS

A feedback device used by a servo amplifier to electronically commutate the motor.

HOLDING TORQUE (STATIC TORQUE)

The maximum restoring torque that is developed by the energized motor when the shaft is slowly rotated by external means. The windings are on but not being switched.

HYBRID STEP MOTOR

A type of step motor comprising a permanent magnet and variable reluctance stator and rotor structures. It uses a double salient pole construction.

HYSTERESIS (POSITIONAL)

The difference between the step positions when moving CW and the step position when moving CCW. A step motor may stop slightly short of the true position thus producing a slight difference in position CW to CCW.

I/O-INPUTS/OUTPUTS

The reception and transmission of information between control devices. I/O has two distinct forms: Digital like switches, relays etc. which are either in an On or Off state and Analog which is a continuous signal in nature such as speed, temperature, flow, etc.

IDLE CURRENT REDUCTION

Reduction of phase current to a step motor when no motion is required.

INDEXER

An electronic control that converts motion commands from a computer terminal into pulse and direction signals for use by a step motor driver.

INDUCTANCE (MUTUAL)

The property that exists between two current carrying conductors or coils when magnetic lines of flux from one link with those of the other.

INDUCTANCE (SELF)

The constant by which the time rate of change of the coil current must be multiplied to give the self-induced counter emf.

INERTIA

Measure of resistance of an object to changes in velocity. The larger the inertia, the more torque required to accelerate and decelerate the load.

INERTIAL MATCH

Ratio of reflected load inertia to motor inertia.

INSTANTANEOUS START/STOP RATE

The maximum switching rate that an unloaded step motor will follow without missing steps when starting from rest.

L/R DRIVE

A drive that uses external resistance to allow a higher voltage than that of a voltage drive. L/R drives have better performance than voltage drives, but have less performance and efficiency than a chopper drive.

LOOP, PID

Proportional, Integral and Derivative Loop-Specialized, high performance control loop.

LOOP, POSITION

A feedback control loop in the which controlled parameter is motor position.

LOOP, VELOCITY

A feedback control loop in which the controlled parameter is velocity.

MAXIMUM REVERSING RATE

The maximum switching rate at which an unloaded motor will reverse direction of rotation without missing steps.

MAXIMUM SLEW RATE

The maximum pulse rate at which a step motor with no load will run and remain in synchronism.

MICROSTEPPING

A technique in which motor steps are electronically divided by the drive into smaller steps. The most common microstep resolutions are 10, 25 and 50 steps per full step, but many resolutions ranging from 2 to 256 microsteps per full step are available.

Glossary

OPEN FRAME DRIVE

Refers to AMP amplifiers where a separate DC power source must be provided to the unit.

OPEN-LOOP

A system with no feedback. Most step motor systems are run in this mode.

OSCILLATOR

A device that is used to produce pulses for driving a step motor at a preset speed. Some of our drives are available with built in oscillators.

OVERSHOOT

The amount a motor shaft rotates beyond the commanded stopping position.

PACKAGED DRIVE

Refers to AMP amplifiers where the power supply is included in the enclosure and 110v/220v is used to power the unit.

PERMANENT MAGNET STEP MOTOR

A step motor having a permanent magnet rotor and wound stator.

PULL-IN RATE (RESPONSE RATE)

The maximum switching rate at which an unloaded motor can start without losing step positions.

PULL-IN TORQUE

The maximum torque load at which a step motor will start and run in synchronism with a fixed frequency pulse train without losing step positions.

PULL-OUT TORQUE

The maximum torque load that can be applied to a motor running at a fixed stepping rate while maintaining synchronism. Any additional load torque will cause the motor to stall or miss steps.

PULSE RATE

The rate at which successive steps are initiated or the windings switched. The pulse rate divided by the resolution of the motor/drive combination (in steps per revolution) equals the rotational speed of the motor in revolutions per second.

PWM

Pulse Width Modulation. A method of controlling motor voltage and current used in servo amplifiers.

RADIAL PLAY

The side to side movement of the shaft due to clearances between the shaft and bearing, bearing to housing, and bearing internal clearance for ball and roller bearings. (Side play)

RATED TORQUE

The torque producing capability of a motor at a given speed. This is the maximum continuous torque the motor can deliver to a load.

REGENERATION

The action during braking, in which the motor acts as a generator and takes kinetic energy from the load, converts it to electrical energy, and returns it to the amplifier.

REPEATABILITY

The degree to which the positioning accuracy for a given move performed repetitively can be duplicated.

RESOLUTION

The smallest positioning increment that can be achieved. Frequently defined as the number of steps or feedback units required for a motor's shaft to rotate one complete revolution.

RESONANCE

The effect of a periodic driving force that causes large amplitude increase at a particular frequency.

RESPONSE RATE (PULL-IN RATE)

The switching rate an unloaded motor can follow from a standing start without missing steps.

RINGING

Oscillation of a system following a sudden change in state.

RS-232, RS422/485

Serial communication protocols

SERIAL PORT

A digital data communications port configured with a minimum number of signal lines.

SERVO AMPLIFIER/SERVO DRIVE

An electronic device which converts a control signal into a high voltage/current which is fed into the motor windings to produce torque in the motor.

SERVO SYSTEM

An automatic feedback control system for mechanical motion in which the controlled or output quantity is position, velocity, or acceleration. Servo systems are closed loop systems.

SETTLING TIME

The elapsed time starting the instant the rotor reaches the commanded step position and the oscillations settle to within a specified displacement band about the final position, usually +/-3 to +/-5 percent.



Glossary

SI

Refers to the AMP Simple Indexer operating environment. Sequences for machine operation are programmed by the use of point and click instructions. Shortens learning curve and allows "non-programmers" to easily sequence machine functions and operations.

SLEW

The portion of a move made at a constant nonzero velocity.

STALL TORQUE (holding or static) The torque available from a motor at stall or zero rpm.

STEP ANGLE

The nominal angle through which the step motor shaft rotates between adjacent step positions.

STEP RATE (SPEED)

The number of steps a shaft rotates during a specified time interval.

STEP-TO-STEP ACCURACY (relative accuracy)

The maximum error that occurs between any adjacent step, expressed as a percentage of one full step.

SWITCHING AMPLIFIER

A device that switches a high voltage on and off to control current. Some amplifiers (PWM types) switch at a constant frequency and adjust duty cycle to control current. Others have a fixed off time and adjust the frequency.

SWITCHING SEQUENCE (ENERGIZING SEQUENCE)

The sequence and polarity of voltages applied to coils of a step motor that result in a specified direction of rotation.

THERMAL TIME CONSTANT

The time required for the motor winding to reach 63.2% of its final temperature.

THERMAL RESISTANCE

The resistance to the flow of energy between two surfaces of the same body or different bodies. Thermal resistance = Winding temperature/Watts in the winding = C/Watt.

TORQUE

The rotary equivalent of force. Equal to the product of the force perpendicular to the radius of motion and distance from the center of rotation to the point where the force is applied.

TORQUE CONSTANT

A number representing the relationship between motor input current and motor output torque. Usually expressed

TORQUE DISPLACEMENT CURVE

The holding (restoring) torque plotted as a function of rotor angular displacement with the motor energized

TORQUE GRADIENT (STIFFNESS)

The ratio of the change in holding torque for a particular change in shaft position when the motor is energized.

TORQUE RIPPLE

The cyclical variation of generated torque given by the product of motor angular velocity and number of commutator segments.

TORQUE-TO-INERTIA RATIO

Ratio of a motor's torque divided by the motor's rotor inertia. The higher the ratio, the higher the acceleration may be.

UNIPOLAR DRIVE

The motor phase winding current is switched in one direction only. The polarity of the applied voltage to each winding is always the same. Unipolar drives require 6 or 8 lead motors. Variable Reluctance Step Motor (V/R) A step motor having a wound stator or stators with salient poles working with a soft iron rotor having salient poles on the periphery.

VELOCITY

The change in position as a function of time. Velocity has both magnitude and direction.

VISCOUS DAMPING

A damper which provides a drag or friction torque proportional to speed. At zero speed, the drag torque is reduced to zero.

VOLTAGE DRIVE

A drive operated at the minimum voltage required to safely limit motor current. Motors used with voltage drives produce less torque at higher speeds than when used with L/R or chopper drives.

WAVE DRIVE

Energizing the phases one at a time. Driving the motor one phase or winding at a time.

INERTIA CONVERSION TABLES

To convert from A to B multiply by entry in table.

A B	lb-ft ²	lb-ft-s ² or slug-ft ²	lb-in ²	lb-in-s ²	oz-in ²	oz-in-s ²	kg-m ²	kg-cm ²	kg-cm-s ²	g-cm ²	g-cm-s ²
lb-ft ²	1	3.108 x 10 ⁻²	144	.373	2.304 x 10 ³	5.968	4.214022 x	421.40	0.4297	4.214 x 10 ⁵	429.71
lb-ft-s ²	32.174	1	4.633 x 10 ⁻³	12	7.413 x 10 ⁴	192	1.35582	1.356 x 10 ⁴	13.825	1.356 x 10 ⁷	1.383 x 10 ⁴
lb-in ²	6.944 x 10 ⁻⁴	2.158 x 10 ⁻⁴	1	2.590 x 10 ⁻³	16	4.144 x 10 ⁻²	2.926404 x	2.926	2.984 x 10 ⁻³	2.926 x 10 ³	2.984
lb-in-s ²	2.681	8.333 x 10 ⁻²	3.861	1	6.177 x 10 ³	16	1.12985 x	1.130 x 10 ³	1.152	1.130 x 10 ⁶	1.152 x 10 ³
oz-in ²	4.34 x 10 ⁻⁴	1.349 x 10 ⁻⁵	6.25 x 10 ⁻²	1.619 x 10 ⁻²	1	2.59 x 10 ⁻³	1.829006 x	0.183	1.865 x 10 ⁻⁴	182.901	0.186
oz-in-s ²	0.168	5.208 x 10 ⁻³	24.13	6.25 x 10 ⁻²	386.088	1	7.06155 x	70.616	7.201 x 10 ⁻²	7.0616 x 10 ⁴	72.008
kg-m ²	34176.16	0.727561	3,417.16	8.85073	54,674.5	141.162	1	10,000	10.1972	1 x 10 ⁷	10,197.2
kg-cm ²	2.373 x 10 ⁻³	7.376 x 10 ⁻⁵	0.3417	8.851 x 10 ⁻⁴	5.467	1.416 x 10 ⁻²	1 x 10 ⁻⁴	1	1.0197 x	1,000	1.0197
kg-cm-s ²	2.327	7.233 x 10 ⁻²	335.109	0.8679	5.362 x 10 ³	13.887	9.806614 x	980.665	1	9.807 x 10 ⁵	1,000
g-cm ²	2.373 x 10 ⁻⁴	7.376 x 10 ⁻⁸	3.417 x 10 ⁻⁴	8.851 x 10 ⁻⁷	5.467 x 10 ⁻³	1.416 x 10 ⁻⁵	1 x 10 ⁻⁷	10 ⁻³	1.0197 x 10 ⁻⁶	1	1.0197 x 10 ⁻³
g-cm-s ²	2.327 x 10 ⁻³	7.233 x 10 ⁻⁵	0.3351	8.680 x 10 ⁻⁴	5.362	1.389 x 10 ⁻²	9.806614 x	.9807	10 ⁻³	980.667	1

Example: Convert a rotor inertia of 90 g-cm² to oz-in-s²
 The multiplier from the table above is 1.416E-05 x 10⁻⁰³ oz-in-s²
 The new inertia = 90 x 1.416 x 10⁻⁵ = 1.27 x 10⁻³ oz-in-sec²

TORQUE CONVERSION TABLES

To convert from A to B multiply by entry in table.

AB	lb-ft	lb-in	oz-in	dyne-cm	N-m	mN-m	kg-cm	g-cm
lb-ft	1	12	192	1.356 x 10 ⁷	1.356	1.356 x 10 ³	13.825	1.3825 x 10 ⁵
lb-in	8.333 x 10 ⁻²	1	16	1.130 x 10 ⁶	0.113	1.13 x 10 ²	1.152	1.152 x 10 ³
oz-in	5.208 x 10 ⁻³	6.250 x 10 ⁻²	1	7.062 x 10 ⁴	7.062 x 10 ⁻³	7.062	7.201 x 10 ⁻²	72.01
dyne-cm	7.376 x 10 ⁻⁸	8.851 x 10 ⁻⁷	1.416 x 10 ⁻⁵	1	10 ⁻⁷	10 ⁻⁴	1.0197 x 10 ⁻⁴	1.0197 x 10 ⁻³
N-m	0.7376	8.851	141.62	10 ⁷	1	1,000	10.197	1.0197 x 10 ⁴
mN-m	7.376 x 10 ⁻⁴	8.851 x 10 ⁻³	0.1416	10 ⁴	10 ⁻³	1	1.0197 x 10 ⁻²	10.197
kg-cm	7.233 x 10 ⁻²	0.8679	13.877	9.8266 x 10 ⁵	9.8066 x 10 ⁻²	98.066	1	1,000
g-cm	7.233 x 10 ⁻⁴	8.6801 x 10 ⁻⁴	1.389 x 10 ⁻²	980.67	9.8066 x 10 ⁻⁵	9.8066 x 10 ⁻²	10 ⁻³	1

Example: Convert a torque of 53 oz-in to kg-cm.
 The multiplier from the table above is 7.201 x 10⁻²
 The new value of torque is 53 x 7.201x10⁻² = 3.816 kg-cm

Sold & Serviced By:



Toll Free Phone (877) SERV098

Toll Free Fax (877) SERV099

www.electromate.com

sales@electromate.com