

Servo Products



- **Three drive series to cover a wide range of motors**
- **Common features and control options**
- **Common software tools for configuration and programming**
- **Multiple communication options, including: Ethernet, EtherNet/IP, RS-232/485 and CANopen**
- **Easy system commissioning and tuning using preconfigured setup files**
- **Point-and-click programming with Si Programmer™**
- **Complex motion, multi-tasking, and third-party HMI support with Q Programmer™**
- **Motors with NEMA and Metric frame sizes**
- **Torques from 0.84 to 64 in-lb**

Servo Drives

- SV7
- SVAC3
- BLuAC5

Servo Motors

- M Series
- V Series

Sold & Serviced By:

 **ELECTROMATE**

Toll Free Phone (877) SERV098

Toll Free Fax (877) SERV099

www.electromate.com

sales@electromate.com



**Applied
Motion
Products**

SVAC3

400W AC Powered Servo Drive

- Operates from 120 or 220 VAC
- Digital PID servo control
- Velocity and acceleration feedforward minimize position error throughout every move
- Digital DQ current loop provides wide bandwidth, precise current control
- Sine commutation for smooth, quiet motion
- PID output filter + derivative filter eliminate system resonances
- Jerk filter provides jerk free "S curve" motion
- Built-in regeneration (power dump) circuit
- 100 Mbit Ethernet
- Flexible control options
- Q Programmable™ version



Control Options*

S

- Pulse & direction
- CW/CCW pulse
- A/B quadrature
- Velocity (oscillator) mode
- Analog +/-10V torque, velocity, position
- Host commands (SCL)
- Quick Tuner™ software for setup

Q

- Stand-alone operation
- Q Programmer™ for complex motion
- Quick Tuner™ software for setup
- Conditional processing
- Math functions
- Multi-tasking
- Register manipulation
- Encoder following
- Third-party HMI compatibility

IP

- EtherNet/IP
- Connects to industry's most popular PLC's
- Same functions as Q model

*See back page for complete list of available model numbers.

For more information, visit:
www.applied-motion.com/SVAC3

Communications

Ethernet Port

- The Ethernet port on all SVAC3 drives is used for configuration, programming, and streaming SCL and Q commands to one or more drives across 100 Mbit Ethernet networks (TCP and UDP).

EtherNet/IP option: SV7-IP-EE

- Allows drives to be commanded and queried over EtherNet/IP industrial networks.

Sold & Serviced By:

 **ELECTROMATE**

Toll Free Phone (877) SERV098

Toll Free Fax (877) SERV099

www.electromate.com

sales@electromate.com

SVAC3 Dimensions

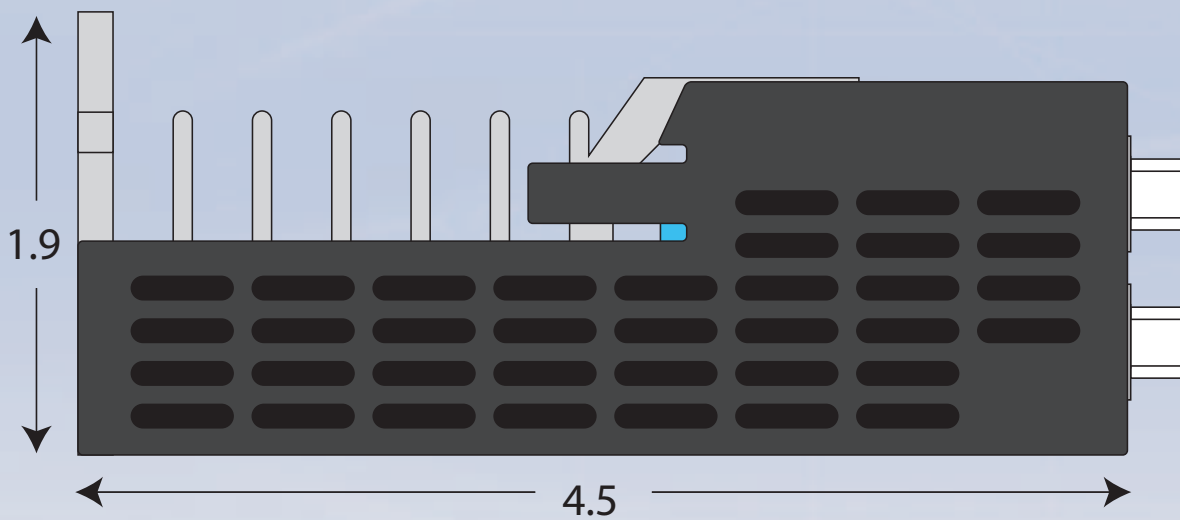
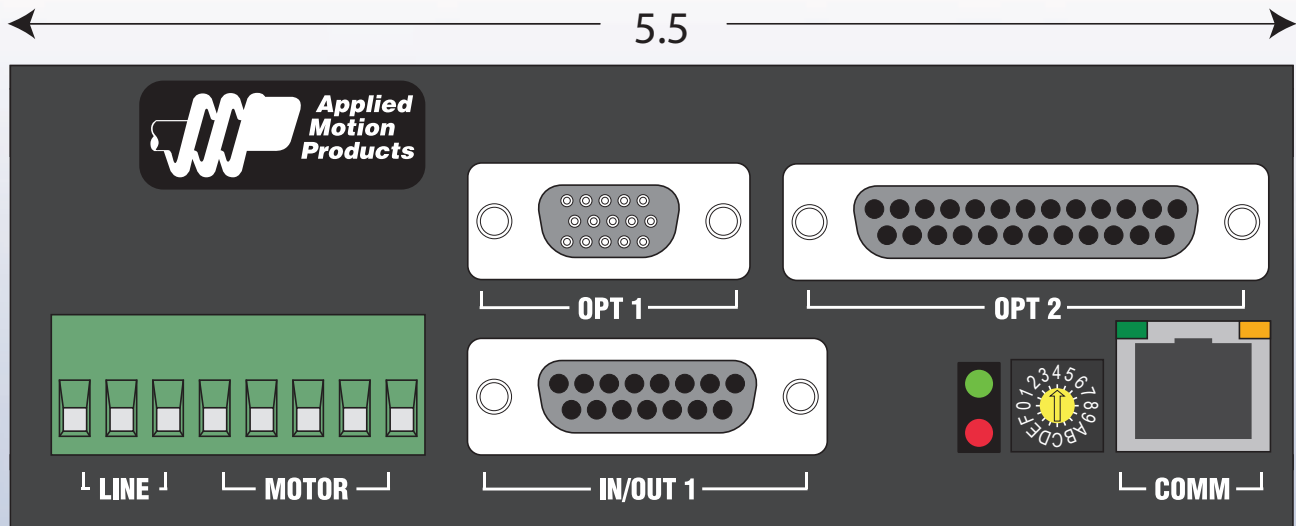

Dimensions in inches
Not to scale

Inputs and Outputs



4 digital inputs
2 digital outputs
1 analog input



12 digital inputs
6 digital outputs
1 analog input



12 digital inputs
6 digital outputs
1 analog input

Sold & Serviced By:



Toll Free Phone (877) SERV098

Toll Free Fax (877) SERV999

www.electromate.com

sales@electromate.com

Torque Curves for 120 Volt SVAC3



Torque Curves for 220 Volt SVAC3

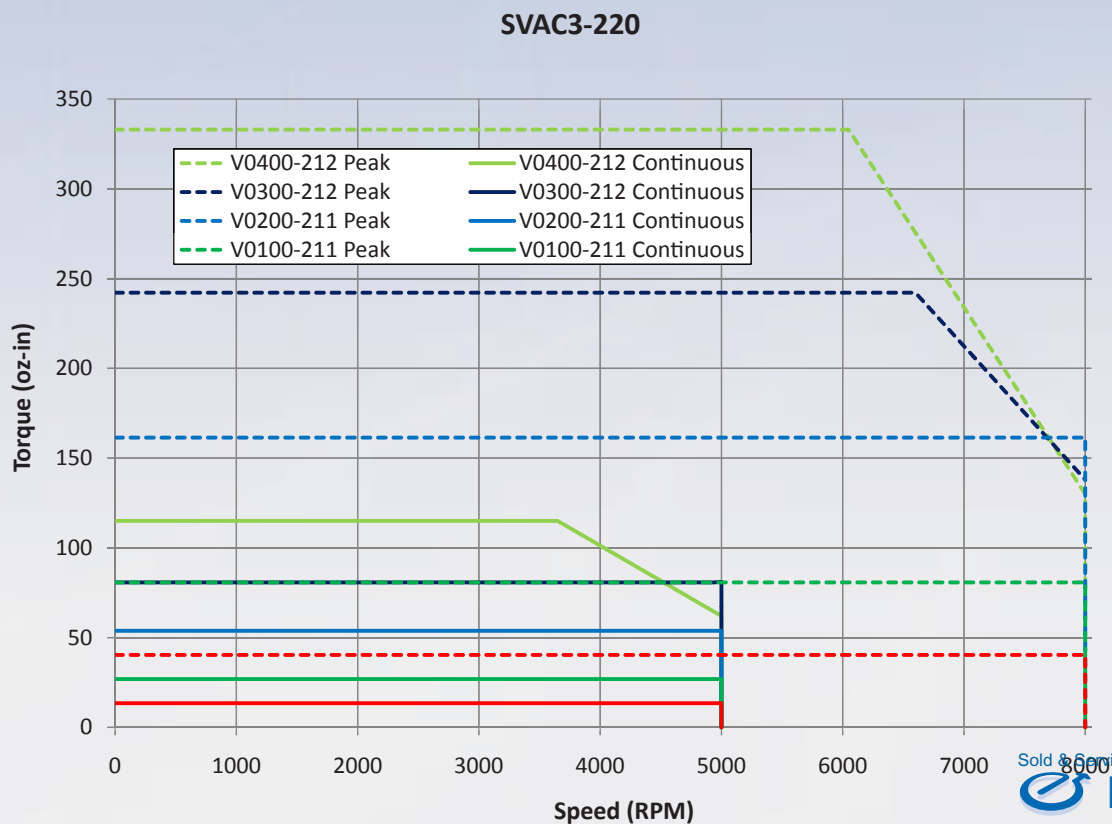

Sold & Shipped By:



Toll Free Phone (877) SERV098

Toll Free Fax (877) SERV099

www.electromate.com

sales@electromate.com

SVAC3 Technical Specifications

POWER AMPLIFIER:

AMPLIFIER TYPE	Digital MOSFET 16 kHz PWM
CURRENT CONTROL	4 quadrant d-q method
OUTPUT CURRENT	SVAC3-120: 0.5 to 3.5 A rms continuous, 0.5 to 7.4 A rms peak (2 seconds max, I2t limiting) SVAC3-220: 0.5 to 1.8 A rms continuous, 0.5 to 5.4 A rms peak (2 seconds max, I2t limiting)
INPUT POWER	SVAC3-120: 108-132 VAC, 50-60 Hz SVAC3-220: 108-242 VAC, 50-60 Hz"
PROTECTION	Over-voltage, under-voltage, over-temp, motor/wiring shorts (phase-to-phase, phase-to-ground)
REGENERATION	Built-in regeneration circuit, 10 watts max
AMBIENT TEMPERATURE	0 to 40 °C (32 to 104 °F), must be mounted to suitable heatsink with adequate ventilation
HUMIDITY	90% max, non-condensing
WEIGHT	22.4 oz

CONTROLLER:

NON-VOLATILE STORAGE	Drive configuration and Q program stored in non-volatile memory
INPUTS/OUTPUTS: S models	X1, X2 inputs: Optically isolated, differential, 5-24 VDC, minimum pulse width = 250 ns, maximum pulse frequency = 2 MHz. Function: step & direction, CW/CCW step, A/B quadrature encoder X3 input: Optically isolated, differential, 5-24 VDC. Function: motor enable X4 input: Optically isolated, differential, 5-24 VDC. Function: alarm reset <i>Note: any input that is not assigned to a dedicated function can be used for a home or registration sensor or for program branching</i> Y1 output: Optical Darlington, sinking or sourcing, 30 VDC max, 100 mA max. Function: brake relay Y2 output: Optical Darlington, sinking or sourcing, 30 VDC max, 100 mA max. Function: fault, motion or tach <i>Note: any output that is not assigned to a dedicated function is general purpose programmable</i> <i>Analog input: Single-ended. Range (resolution) is software selectable 0-5 VDC (10 bits), +/-5 or 0-10 VDC (11 bits), or +/-10 VDC (12 bits). Software configurable offset, deadband and filtering.</i>
INPUTS/OUTPUTS: Q and IP models	X1, X2 inputs: Optically isolated, differential, 5-24 VDC, minimum pulse width = 250 ns, maximum pulse frequency = 2 MHz. Function: step & direction, CW/CCW step, A/B quadrature encoder X3 input: Optically isolated, differential, 5-24 VDC. Function: motor enable X4 input: Optically isolated, differential, 5-24 VDC. Function: alarm reset IN1, IN2 inputs: Optically isolated, differential, 5-24 VDC. Function: jogging IN3-IN6 inputs: Optically isolated, sinking w/ shared common, 12-24 VDC IN7, IN8 inputs: Optically isolated, differential, 5-24 VDC. Function: CW and CCW limits <i>Note: any input that is not assigned to a dedicated function can be used for a home or registration sensor or for program branching.</i> Y1 output: Optical Darlington, sinking or sourcing, 30 VDC max, 100 mA max. Function: brake relay Y2 output: Optical Darlington, sinking or sourcing, 30 VDC max, 100 mA max. Function: fault OUT1 output: Optical Darlington, sinking, 30 VDC max, 100 mA max. Function: motion or tach OUT2, OUT3 outputs: Optical Darlington, sinking, 30 VDC max, 100 mA max OUT4 output: Optical Darlington, sinking or sourcing, 30 VDC max, 100 mA max <i>Note: any output that is not assigned to a dedicated function is general purpose programmable</i> <i>Analog input: Single-ended. Range (resolution) is software selectable 0-5 VDC (10 bits), +/-5 or 0-10 VDC (11 bits), or +/-10 VDC (12 bits). Software configurable offset, deadband and filtering.</i>
COMMUNICATION INTERFACE	All models: Ethernet 100BASE-T, supports TCP and UDP IP models only: EtherNet/IP industrial networking
ENCODER INTERFACE	Differential line receivers for incremental encoder (A/B quadrature) feedback, up to 2 MHz. 400 cpr min to 32,768 cpr max (1600 quadrature counts min to 131,072 quadrature counts max)
AGENCY APPROVALS	RoHS CE EN61800-3:2004, EN61800-5-1:2003 UL 508C

Sold & Serviced By:



Toll Free Phone (877) SERV098
Toll Free Fax (877) SERV099
www.electromate.com
sales@electromate.com

BLuAC5

1000W AC Powered Servo Drive

- Operates from 100 to 240 VAC, 1 or 3 phase
- Digital PID servo control
- Velocity and acceleration feedforward minimize position error throughout every move
- Digital DQ current loop provides wide bandwidth, precise current control
- Sine commutation for smooth, quiet motion
- PID output filter + derivative filter eliminate system resonances
- Built-in regeneration (power dump) circuit
- Dynamic braking
- RS-232, RS-485
- Flexible control options
- Si and Q Programmable™ versions



For more information, visit:
www.applied-motion.com

Control Options*

S

- Pulse & direction
- CW/CCW pulse
- A/B quadrature
- Velocity (oscillator) mode
- Analog +/-10V torque, velocity, position
- Host commands (SCL)
- SiNet hub compatible
- Quick Tuner™ software for setup

Q

- Stand-alone operation
- Q Programmer™ for complex motion
- Quick Tuner™ software for setup
- Conditional processing
- Math functions
- Multi-tasking
- Register manipulation
- Encoder following
- Third-party HMI compatibility
- QE adds additional I/O

Si

- Si Programmer™ point-and-click indexer software with built-in Quick Tuner™
- User-friendly GUI
- I/O and motion programming
- Operator interface available (MMI-01 or MMI-02)

*See back page for complete list of available model numbers.

Communications

RS-232 port

Standard on all drives

- The RS-232 port is used for configuration, programming, and sending SCL and Q commands to a single drive.

RS-485 port

Standard on all drives

- The RS-485 port can be used to stream SCL and Q commands to one or more drives across a serial network.

Sold & Serviced By:

 **ELECTROMATE**

Toll Free Phone (877) SERV098

Toll Free Fax (877) SERV099

www.electromate.com

sales@electromate.com

BLuAC5 Dimensions

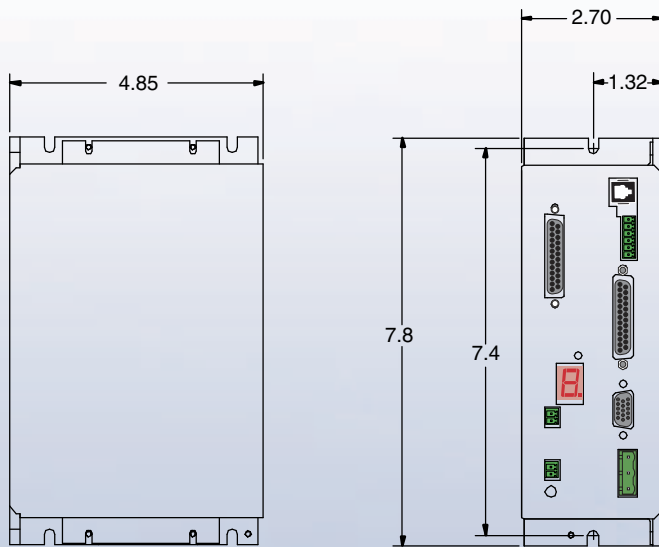

Dimensions in Inches
Not to scale

Inputs and Outputs



7 digital inputs
3 digital outputs
2 analog inputs



7 digital inputs
3 digital outputs
2 analog inputs



15 digital inputs
7 digital outputs
3 analog inputs



15 digital inputs
7 digital outputs

Torque Curves for BLuAC5

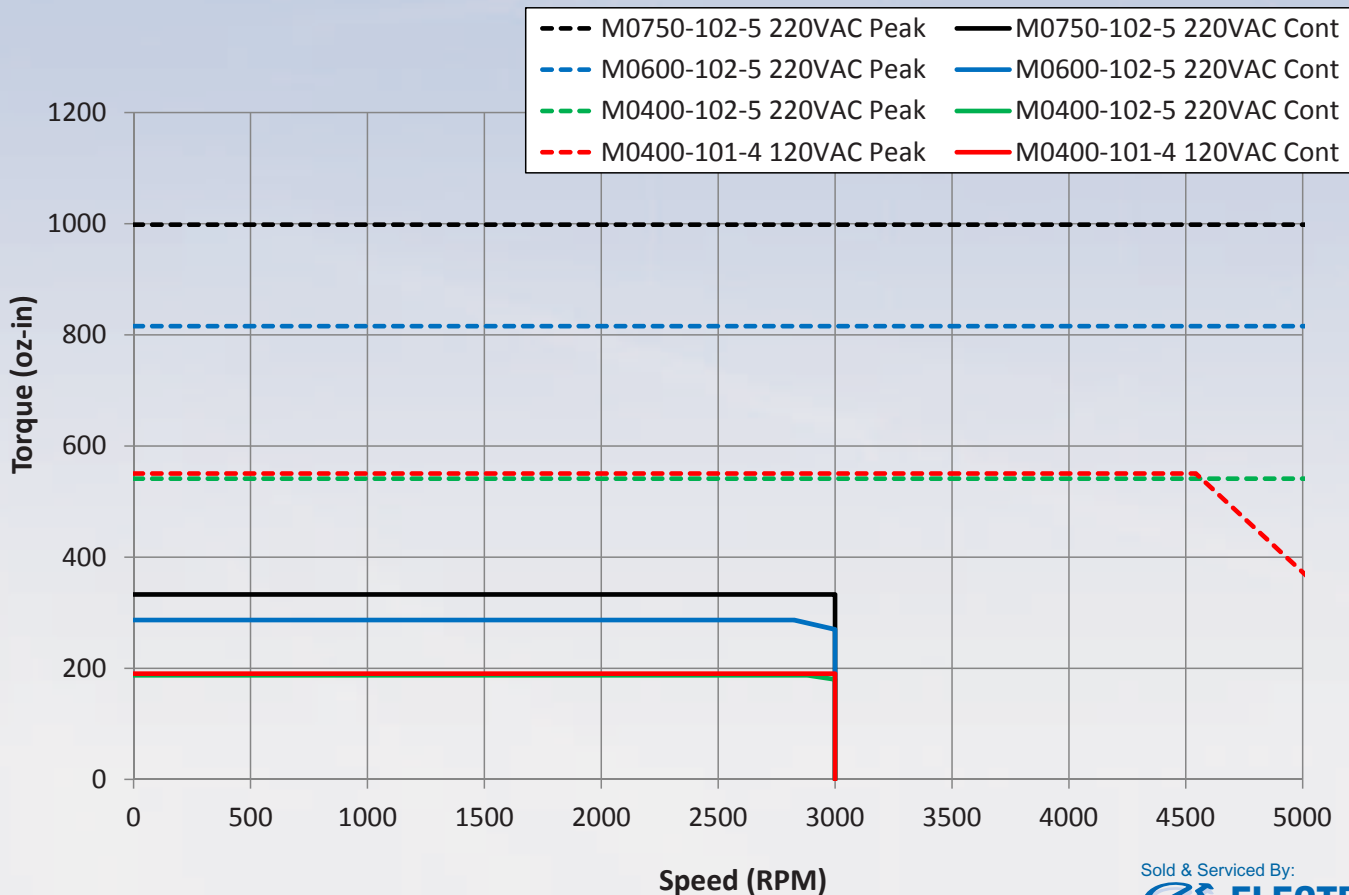

Sold & Serviced By:



Toll Free Phone (877) SERV098

Toll Free Fax (877) SERV099

www.electromate.com

sales@electromate.com

BLuAC5 Technical Specifications

POWER AMPLIFIER:

AMPLIFIER TYPE	3-phase sinusoidal PWM switching at 16 kHz
CURRENT CONTROL	4 quadrant d-q method
OUTPUT CURRENT	Up to 5 A rms continuous, up to 15 A rms peak (2 seconds max, I _{2t} limiting)
INPUT POWER	90-260 VAC, 50/60 Hz, 1-phase or 3-phase
PROTECTION	Over-voltage (400 VDC on DC bus), under-voltage (100 VDC on DC bus), over-temp (75 °C), motor/wiring shorts (phase-to-phase, phase-to-ground), regeneration error (based on regeneration values input by user), encoder failure (differential encoders only), Hall sensor failure
REGENERATION	50 Watt internal shunt resistor, connector for external high-power shunt resistor
AMBIENT TEMPERATURE	0 to 40 °C (32 to 104 °F), must be mounted to suitable heatsink with adequate ventilation
HUMIDITY	90% max, non-condensing
WEIGHT	S and Q models: 35.1 oz QE and Si models: 44 oz

CONTROLLER:

NON-VOLATILE STORAGE	Drive configuration and programs stored in non-volatile memory
INPUTS/OUTPUTS: S and Q models	X1, X2 inputs: Optically isolated, differential, 5 VDC X3-X7 inputs: Optically isolated, single-ended w/ shared common, 12-24 VDC Y1-Y3 outputs: Optical Darlington, sinking w/ shared common, 30 VDC max, 100 mA max Analog inputs: Two single-ended inputs can be wired together as one differential input. Range is software selectable 0-5 VDC, +/-5, 0-10 VDC, or +/-10 VDC. Software configurable offset, deadband and filtering on differential input only
INPUTS/OUTPUTS: QE and Si models	X1, X2 inputs: Optically isolated, differential, 5 VDC X3-X7 inputs: Optically isolated, single-ended w/ shared common, 12-24 VDC IN1-IN6 inputs: Optically isolated, single-ended w/ shared common, 12-24 VDC IN7, IN8 inputs: Optically isolated, differential, 12-24 VDC Y1-Y3 outputs: Optical Darlington, sinking w/ shared common, 30 VDC max, 100 mA max OUT1-OUT4 outputs: Optical Darlington, sinking or sourcing, 30 VDC max, 100 mA max Analog inputs: Two single-ended inputs can be wired together as one differential input. Range is software selectable 0-5 VDC, +/-5, 0-10 VDC, or +/-10 VDC. Software configurable offset, deadband and filtering on differential input only. <i>Note: Si Programming does not support the analog input(s).</i>
COMMUNICATION INTERFACE	RS-232 for configuration, programming and serial communications to a single drive RS-485 for serial communications to one or more drives on a serial network
ENCODER INTERFACE	Differential line receivers for incremental encoder (A/B quadrature) feedback, up to 2 MHz. 50 cpr min to 8192 cpr max (200 quadrature counts min to 32,768 quadrature counts max)
AGENCY APPROVALS	RoHS CE

Sold & Serviced By:



Toll Free Phone (877) SERV098
Toll Free Fax (877) SERV099
www.electromate.com
sales@electromate.com

SV7

300W DC Powered Servo Drive

- Operates from 24 to 80 VDC
- Digital PID servo control
- Velocity and acceleration feedforward minimize position error throughout every move
- Digital DQ current loop provides wide bandwidth, precise current control
- Sine commutation for smooth, quiet motion
- PID output filter + derivative filter eliminate system resonances
- Jerk filter provides jerk free "S curve" motion
- RS-232, RS-485, CANopen, Ethernet
- Flexible control options
- Si and Q Programmable™ versions



Control Options*

S

- Pulse & direction
- CW/CCW pulse
- A/B quadrature
- Velocity (oscillator) mode
- Analog +/-10V torque, velocity, position
- Host commands (SCL)
- SiNet Hub compatible
- Quick Tuner™ software for setup

Q

- Stand-alone operation
- Q Programmer™ for complex motion
- Quick Tuner™ software for setup
- Conditional processing
- Math functions
- Multi-tasking
- Register manipulation
- Encoder following
- Third-party HMI compatibility

Si

- Si Programmer™ with built-in Quick Tuner™
- Point-and-click indexing software
- User-friendly GUI
- I/O and motion programming
- Operator interface available (MMI-01 or MMI-02)

C

- CANopen protocols DS301 and DSP402
- Profile Position, Profile Velocity, and Homing modes
- Up to 127 axes per channel
- Execute stored Q programs

IP

- EtherNet/IP
- Connects to industry's most popular PLC's
- Same functions as Q model

*See back page for complete list of available model numbers.

For more information go to
www.applied-motion.com/SV

Communications

Ethernet option: SV7-Q-EE

- The Ethernet option board allows the SV7-Q-EE to be commanded and queried over standard 100Mbit Ethernet using the SCL and Q languages.

CANopen option: SV7-C-CE

- The CANopen option board used with the SV7-C-CE allows the drive to be connected to a CANopen network along with other CANopen drives. Drives can be controlled and interrogated over the network.

RS-485 option: SV7-Q-RE, SV7-S-RE

- The RS-485 option board adds the ability to stream SCL and Q commands to one or more drives on a serial network.

RS-232 port: standard on all but Ethernet drives

Example: SV7-S-AF

- The RS-232 port is used for configuration, programming, and serial communications with a single drive.

EtherNet/IP option: SV7-IP-EE

- Allows drives to be commanded and queried over Ethernet industrial networks.

Sold & Serviced By:

ELECTROMATE

Toll Free Phone (877) SERV098

Toll Free Fax (877) SERV099

www.electromate.com

sales@electromate.com

SV7 Dimensions

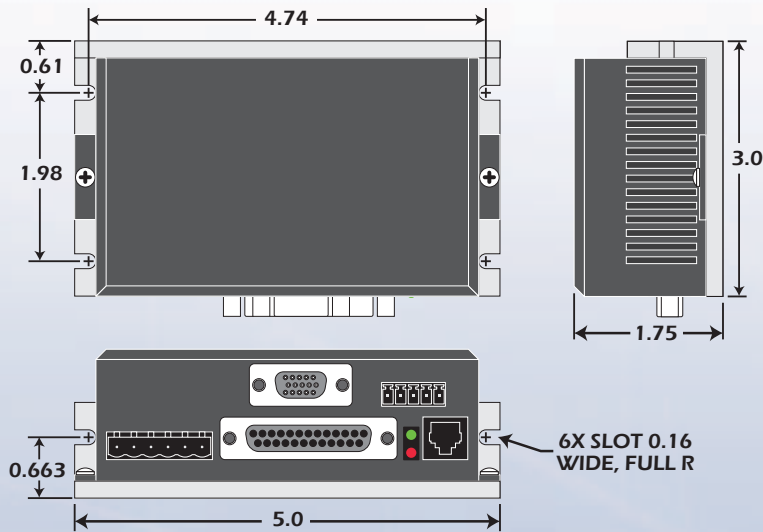

Dimensions in Inches
Not to scale

Inputs and Outputs



8 digital inputs
4 digital outputs
2 analog inputs



8 digital inputs
4 digital outputs
2 analog inputs



8 digital inputs
4 digital outputs



8 digital inputs
4 digital outputs
2 analog inputs



8 digital inputs
4 digital outputs
2 analog inputs

Torque Curves for SV7 at 24 VDC

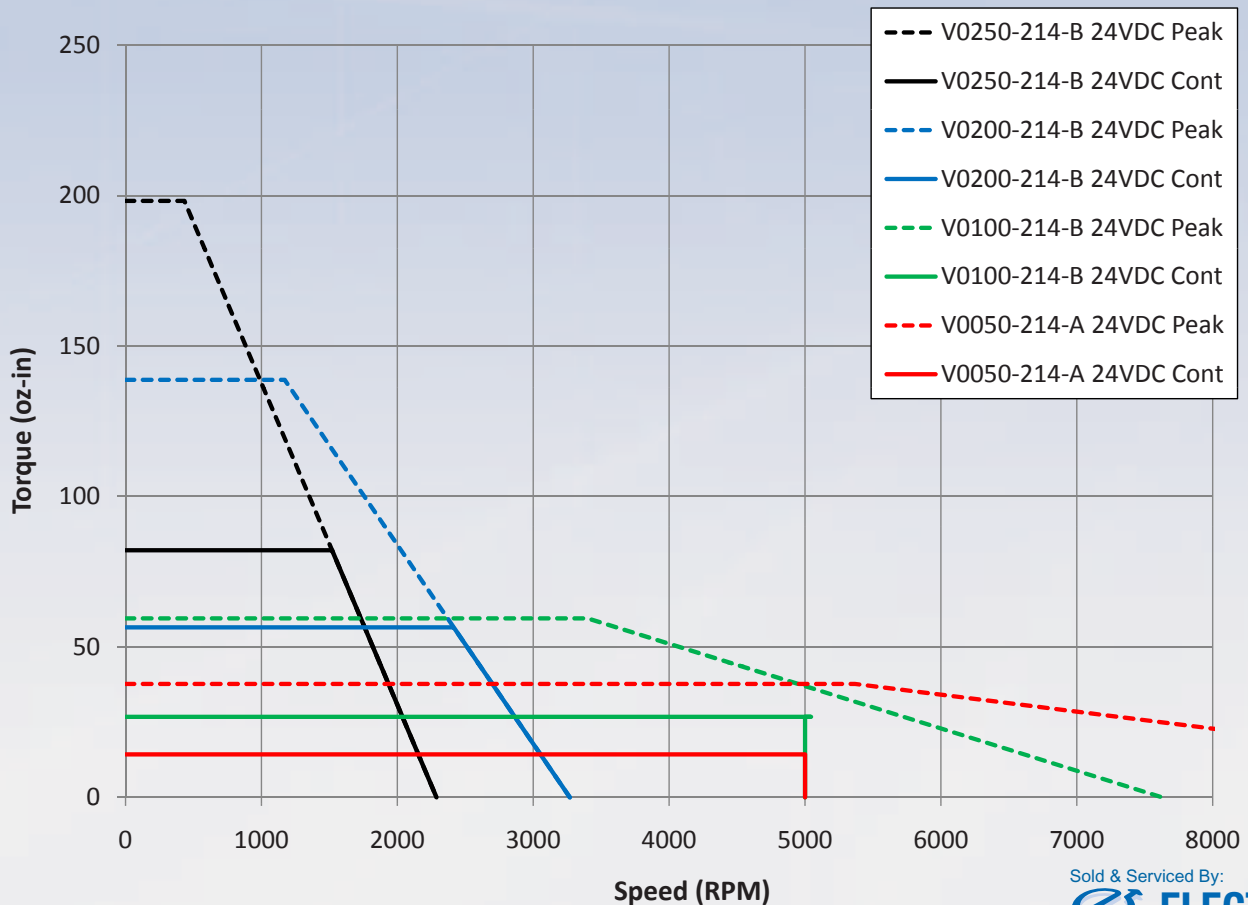

More curves available at www.applied-motion.com

Sold & Serviced By:



Toll Free Phone (877) SERV098

Toll Free Fax (877) SERV099

www.electromate.com

sales@electromate.com

Torque Curves for SV7 at 48 VDC

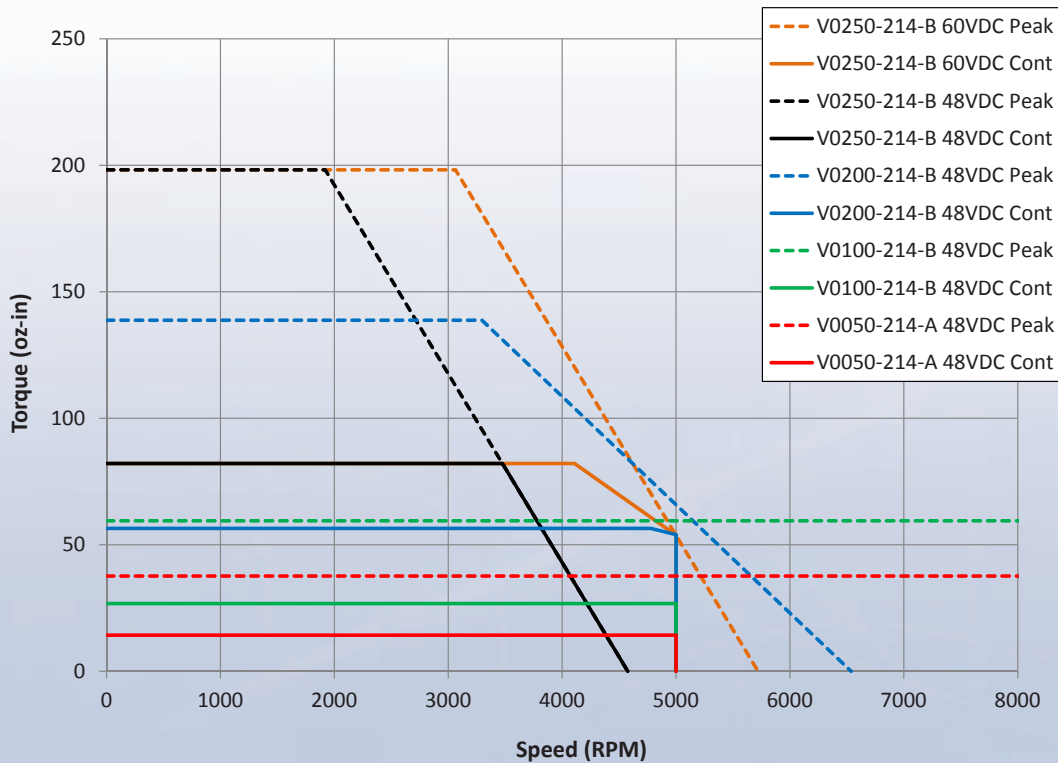

SV7 Technical Specifications

POWER AMPLIFIER: All Models

AMPLIFIER TYPE	Digital MOSFET 16 kHz PWM
CURRENT CONTROL	4 quadrant d-q method
OUTPUT CURRENT	0.5 to 7.0 A rms continuous, 0.5 to 14 A rms peak (2 seconds max, I _{2t} limiting)
INPUT POWER	24-80 VDC (external power supply required)
PROTECTION	Over-voltage, under-voltage, over-temp, motor/wiring shorts (phase-to-phase, phase-to-ground)
REGENERATION	No internal regeneration circuit. RC-050 external regeneration clamp may be required for applications with high load inertia and/or rapid deceleration
AMBIENT TEMPERATURE	0 to 40 °C (32 to 104 °F), must be mounted to suitable heatsink with adequate ventilation
HUMIDITY	90% max, non-condensing
WEIGHT	10 oz

CONTROLLER: All Models

NON-VOLATILE STORAGE	Drive configuration and Q program stored in non-volatile memory
INPUTS/OUTPUTS	<p>X1, X2 inputs: Optically isolated, differential, 5 VDC, minimum pulse width = 250 ns, maximum pulse frequency = 2 MHz. Function: step & direction, CW/CCW step, A/B quadrature encoder</p> <p>X3 input: Optically isolated, sinking or sourcing, 12-24 VDC. Function: motor enable</p> <p>X4 input: Optically isolated, sinking or sourcing, 12-24 VDC. Function: alarm reset</p> <p>X5, X6 inputs: Optically isolated, sinking or sourcing, 12-24 VDC. Function: CW and CCW jog inputs <i>Note: inputs X3-X6 have a shared common.</i></p> <p>X7, X8 inputs: Optically isolated, differential, 12-24 VDC. Function: CW and CCW limits <i>Note: any input that is not assigned to a dedicated function can be used for a home or registration sensor or for program branching.</i></p>

Sold & Serviced By:

 **ELECTROMATE**

Continued on page 12
Toll Free Phone (877) SERV098

Toll Free Fax (877) SERV099

www.electromate.com 11

sales@electromate.com

SV7 Technical Specifications (Continued)

CONTROLLER (CONT): All Models

INPUTS/OUTPUTS (CONT)	<p>Y1 output: Optical Darlington, NPN/sinking, 30 VDC max, 100 mA max. Function: brake relay</p> <p>Y2 output: Optical Darlington, NPN/sinking, 30 VDC max, 100 mA max. Function: motion or tach</p> <p>Y3 output: Optical Darlington, NPN/sinking, 30 VDC max, 100 mA max. Function: fault</p> <p><i>Note: outputs Y1-Y3 have a shared common.</i></p> <p>Y4 output: Optical Darlington, sinking or sourcing, 30 VDC max, 100 mA max</p> <p><i>Note: any output that is not assigned to a dedicated function is general purpose programmable.</i></p> <p>Analog input: Single-ended. Range (resolution) is software selectable 0-5 VDC (10 bits), +/-5 or 0-10 VDC (11 bits), or +/-10 VDC (12 bits). Software configurable offset, deadband and filtering.</p>
COMMUNICATION INTERFACE	<p>SV7-x-Ax: RS-232 for programming and serial communications</p> <p>SV7-x-RE: RS-232 for programming and serial communications, RS-485 for serial communications</p> <p>SV7-Q-EE: Ethernet for programming and serial communications</p> <p>SV7-C-CE: RS-232 for programming, CANopen for communications</p> <p>SV7-IP-EE: Ethernet for programming, EtherNet/IP for network communications"</p>
ENCODER INTERFACE	Differential line receivers for incremental encoder (A/B quadrature) feedback, up to 2 MHz. 400 cp min to 32,768 cpr max (1600 quadrature counts min to 131,072 quadrature counts max)
AGENCY APPROVALS	RoHS CE EN61800-3:2004, EN61800-5-1:2003"

Software for All Drives

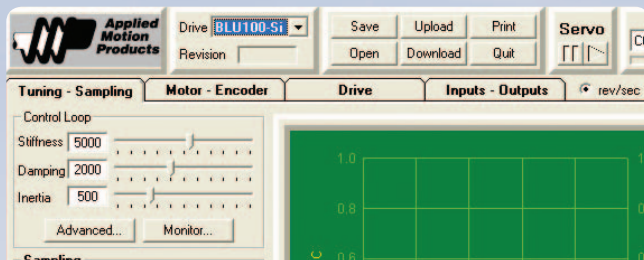

Quick Tuner™

Used for setup and configuration of the drive. For more information about *Quick Tuner™*, visit the Applied Motion Products website.

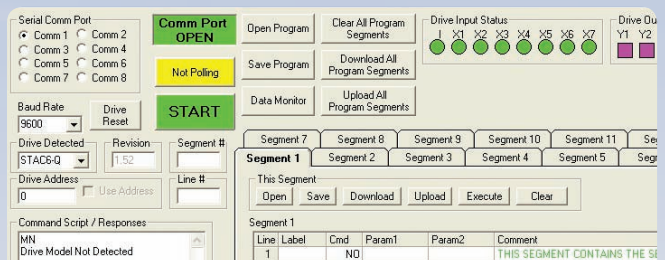

Q Programmer™

Q Programmer™ is used to create and edit stand-alone programs for Q version drives. These programs can include multi-tasking, math, register manipulation, encoder following, and more.

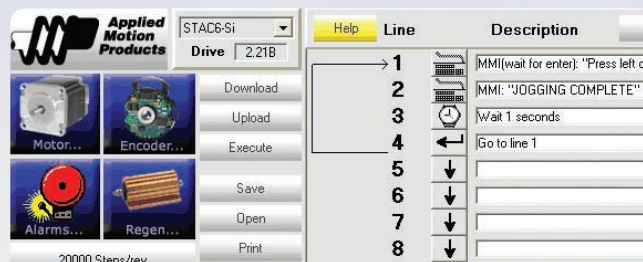

Si Programmer™

Intended for use in stand-alone applications, *Si Programmer™* provides a user friendly, point-and-click, graphical interface that doesn't require any previous programming experience. Currently available on SV7 and BLuAC5 servo drives only.

All software applications run on Windows 7, Windows Vista, XP, 2000, NT, ME, 98.

Sold & Serviced By:

ELECTROMATE

Toll Free Phone (877) SERV098

Toll Free Fax (877) SERV099

www.electromate.com

sales@electromate.com

Servo Motor Data



- M Series Motors:**
- High torque density
 - Metric frame sizes
 - 2000 line (8000 count) incremental encoder



- V Series Motors:**
- Economical package
 - NEMA frame sizes
 - 2048 line (8192 count) incremental encoder

Part #	Supply Voltage	Frame Size	Rated Power (Watts)	Cont. Peak Torque (in-lb)	Rated Peak Speed (rpm)	Torque Constant (in-lb/A)	Voltage Constant (V/krpm)	Rotor Inertia (oz-in-sec ²)
M0100-103-3-000	24 VDC	40 mm	100	2.8 8.4	3000 5000	0.4	4.8	4.25E-04
M0100-103-4-000	24 VDC	60 mm	100	2.8 8.4	3000 5000	0.39	4.6	1.27E-03
V0050-214-A-000	48 VDC	NEMA 17	50	0.84 2.6	5000 8000	0.168	2.0	4.11E-04
V0100-214-B-000	48 VDC	NEMA 23	100	1.68 5.0	5000 8000	0.266	3.5	1.32E-03
V0200-214-B-000	48 VDC	NEMA 23	200	3.36 10	5000 5900	0.62	7.4	2.58E-03
V0250-214-B-000	48 VDC	NEMA 23	200	5.0 15	3350 4000	0.885	10.7	3.82E-03
M0200-104-4-000	48 VDC	60 mm	200	5.7 17	3000 5000	0.93	11	2.55E-03
M0400-105-4-000	60 VDC	60 mm	400	11 34	3000 5000	1.41	16.8	4.81E-03
V0050-211-A-000	120 VAC	NEMA 17	50	0.84 2.6	5000 8000	0.053	5.54	4.11E-04
V0100-211-B-000	120 VAC	NEMA 23	100	1.68 5.0	5000 8000	1.04	12.2	1.32E-03
M0100-101-3-000	120 VAC	40 mm	100	2.8 8.4	3000 5000	2.8	19.3	4.25E-04
M0100-101-4-000	120 VAC	60 mm	100	2.8 8.4	3000 5000	1.68	19.9	1.27E-03
V0200-211-B-000	120 VAC	NEMA 23	200	3.36 10	5000 8000	1.93	22.8	2.58E-03
V0300-211-B-000	120 VAC	NEMA 23	300	5.0 15	4860 6800	1.86	22.4	3.82E-03
M0200-101-4-000	120 VAC	60 mm	200	5.7 17	3000 5000	1.77	20.5	2.55E-03
V0400-211-C-000	120 VAC	NEMA 34	400	6.7 20	5000 8000	2.5	29	1.44E-02
M0400-101-4-000	120 VAC	60 mm	400	11 34	3000 5000	2.12	24.8	4.81E-03
V0300-212-B-000	220 VAC	NEMA 23	300	5.0 15	5000 8000	2.83	33.7	3.82E-03
M0200-102-4-000	220 VAC	60 mm	200	5.7 17	3000 5000	3.45	41	2.55E-03
V0400-212-C-000	220 VAC	NEMA 34	400	6.7 20	5000 8000	4.04	45.6	1.44E-02
M0400-102-5-000	220 VAC	80 mm	400	11 34	3000 5000	4.3	50.8	7.93E-03
M0750-102-5-000	220 VAC	80 mm	750	21 64	3000 5000	4.4	52.2	1.53E-02

Servo Motor Extension Cables

ENCODER EXTENSION CABLE FOR V SERIES MOTORS

- VA-ENC-CA-06 - 6 ft
- VA-ENC-CA-10 - 10 ft

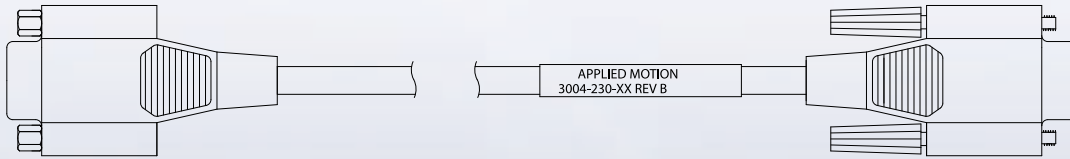

MOTOR EXTENSION CABLE FOR V SERIES MOTORS

- VA-MTR-CA-06 - 6 ft
- VA-MTR-CA-10 - 10 ft

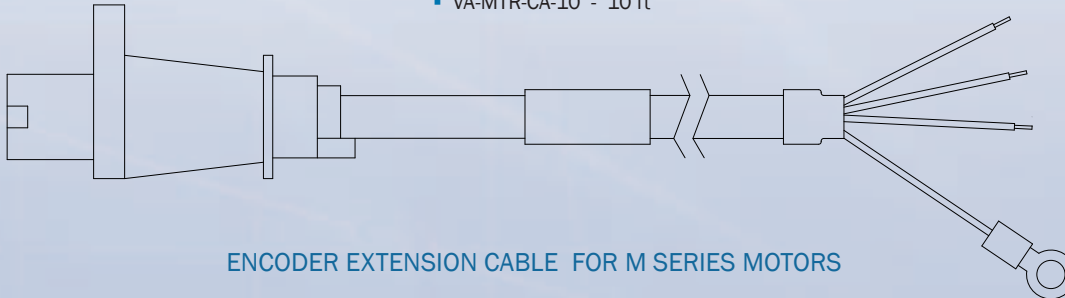

ENCODER EXTENSION CABLE FOR M SERIES MOTORS

- BLUENC-CA-04 - 4 ft
- BLUENC-CA-10 - 10 ft
- BLUENC-CA-20 - 20 ft

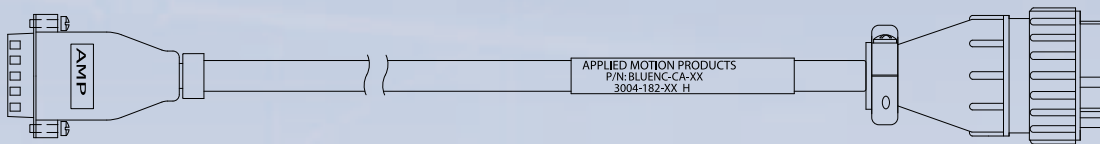

MOTOR EXTENSION CABLE FOR M SERIES MOTORS

for use with BLuAC5 Drives

- BLUMTR-FA-04 - 4 ft
- BLUMTR-FA-10 - 10 ft
- BLUMTR-FA-20 - 20 ft



MOTOR EXTENSION CABLE FOR M SERIES MOTORS

for use with SV7 and SVAC3 Drives

- BLUMTR-CA-04 - 4 ft
- BLUMTR-CA-10 - 10 ft
- BLUMTR-CA-20 - 20 ft

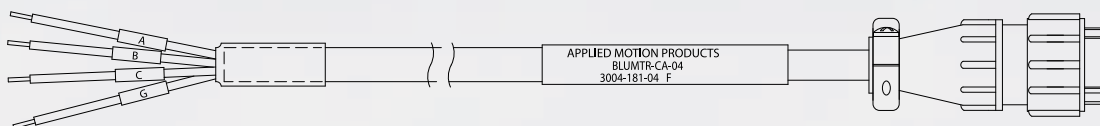

Sold & Serviced By:



Toll Free Phone (877) SERV098

Toll Free Fax (877) SERV099

www.electromate.com

sales@electromate.com

Accessories

Power Supplies

Applied Motion offers two matched power supplies for use with the SV7 drives. A 24VDC 150W (part number: PS150A24) and a 48VDC 320W version (part number: PS320A48). These power supplies have current over load capability making them ideal for use with servo drives.



Break Out Boards: BOB-1 and BOB-2

BOB-1 is for use with all drives and expands the DB25F connector to screw terminals. BOB-2 is for use with the DB25M connector on the BLuAC5-Si and -QE. A 3 foot cable included with both models.



RC-050 Regeneration Clamp (for SV7)

The RC-050 regeneration clamp is for use where regeneration from the motor may be excessive for the power supply. In these cases, the RC-050 is connected between the drive and power supply and absorbs regenerated energy.

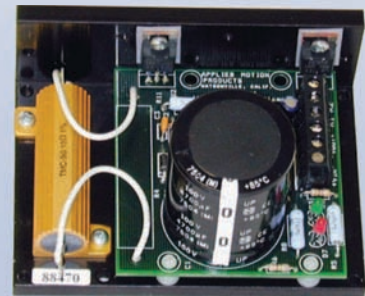

Braking resistor assembly - RA-100

For use with BLuAC5 dynamic braking and regeneration circuits.

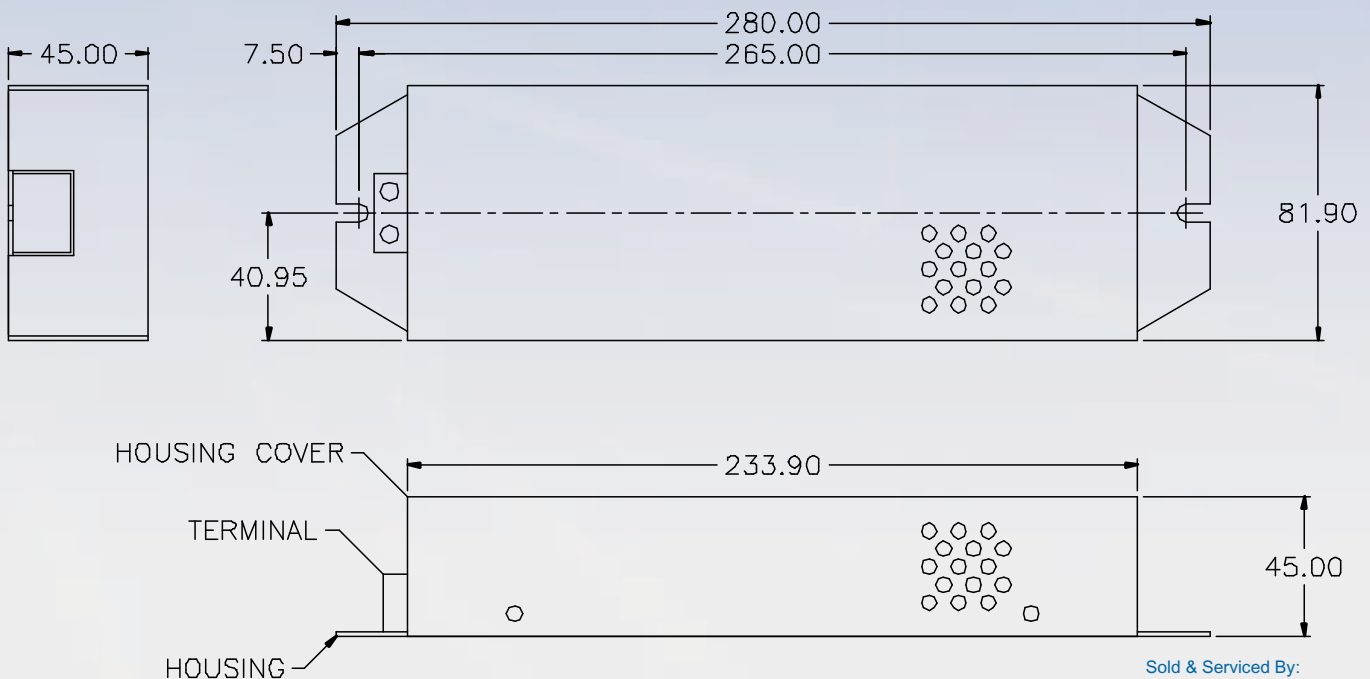

Sold & Serviced By:

ELECTROMATE

Toll Free Phone (877) SERV098

Toll Free Fax (877) SERV099

www.electromate.com

sales@electromate.com

Servo Drive Model Numbers

SVAC3-S-E120

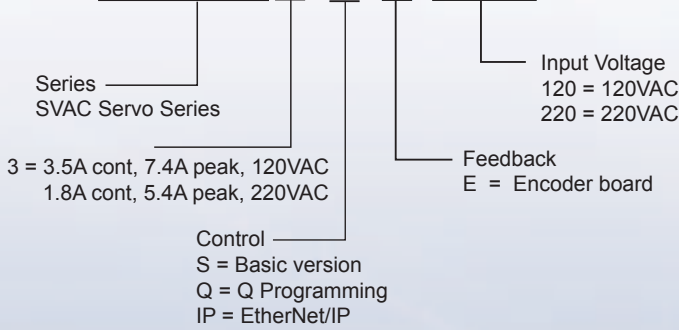

BLuAC5-Si

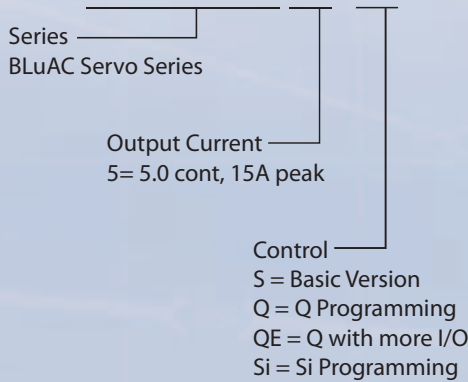

SV7-S-RE

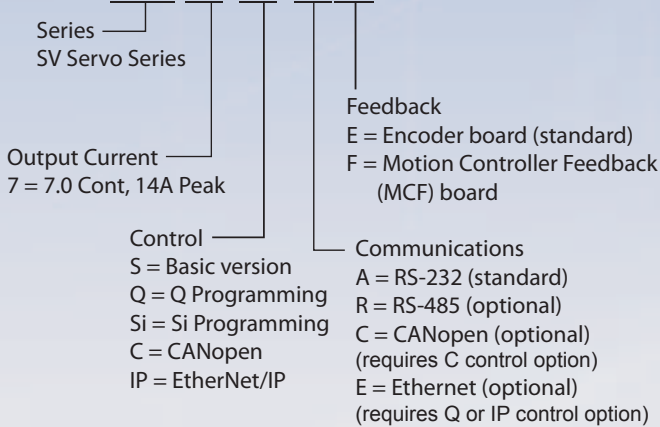

Model Numbers	Q Programming	Si Programming	RS-232	RS-422/485	Ethernet	EtherNet/IP	CANopen	Encoder Output
SVAC3-S-E120					X			
SVAC3-S-E220					X			
SVAC3-Q-E120	X				X			
SVAC3-Q-E220	X				X			
SVAC3-IP-E120	X				X	X		
SVAC3-IP-E220	X				X	X		
BLuAC5-S			X	X				X
BLuAC5-Q	X		X	X				X
BLuAC5-QE	X		X	X				X
BLuAC5-Si		X	X	X				X
SV7-S-AE			X					
SV7-S-AF			X					X
SV7-S-RE			X	X				
SV7-Q-AE	X		X					
SV7-Q-AF	X		X					X
SV7-Q-RE	X		X	X				
SV7-Q-EE	X				X			
SV7-Si-AE		X	X					
SV7-Si-AF		X	X					X
SV7-C-CE			X				X	
SV7-IP-EE	X				X	X		



Sold & Serviced By:



Toll Free Phone (877) SERV098

Toll Free Fax (877) SERV099

925-0008-59-2011

www.electromate.com

sales@electromate.com