

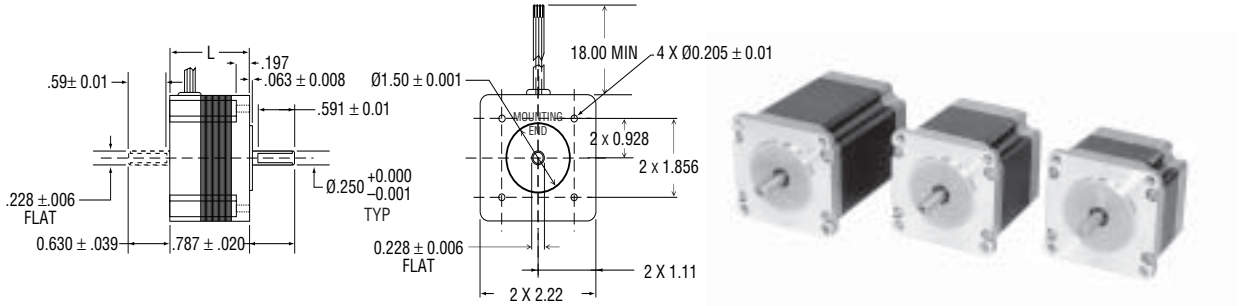

STEP MOTORS

Hybrid Step Motors

SIZE
HT
23



Part #	MOTOR CONNECTION 1 = series 2 = parallel 3 = unipolar	Motor Length (inches)	Minimum Holding Torque (oz-in)	Leads	Step Angle	Electrical				Rotor Inertia (oz-in ² /G-CM ²)	Motor Weight (Lbs.)
						Volts	Amps	Ohms	mH		
HT23-393	1	1.54	76.6	8	1.8	7.4	0.71	10.4	21.6	0.66/120	1.0
	2	↓	76.6	↓	↓	3.7	1.41	2.6	5.4	↓	↓
	3	↓	54.2	↓	↓	5.2	1.00	5.2	5.4	↓	↓
HT23-394	1	↓	76.6	↓	↓	4.0	1.41	2.8	5.6	↓	↓
	2	↓	76.6	↓	↓	2.0	2.83	0.7	1.4	↓	↓
	3	↓	54.2	↓	↓	2.8	2.00	1.4	1.4	↓	↓
HT23-395	1	↓	76.6	↓	↓	2.7	2.12	1.3	2.4	↓	↓
	2	↓	76.6	↓	↓	1.3	4.24	0.3	0.6	↓	↓
	3	↓	54.2	↓	↓	1.9	3.00	0.6	0.6	↓	↓
HT23-396	1	2.13	177.0	↓	↓	10.2	0.71	14.4	44.0	1.64/300	1.54
	2	↓	177.0	↓	↓	5.1	1.41	3.6	11.0	↓	↓
	3	↓	125.0	↓	↓	7.2	1.00	7.2	11.0	↓	↓
HT23-397	1	↓	177.0	↓	↓	5.1	1.41	3.6	10.0	↓	↓
	2	↓	177.0	↓	↓	2.5	2.83	0.9	2.5	↓	↓
	3	↓	125.0	↓	↓	3.6	2.00	1.8	2.5	↓	↓

OTHER LENGTHS AND WINDINGS AVAILABLE UPON REQUEST

- Part numbers listed are for single shaft. To order double shaft add 'D' to the end.
- All HT23 motors are optimized for microstepping.



STEP MOTORS

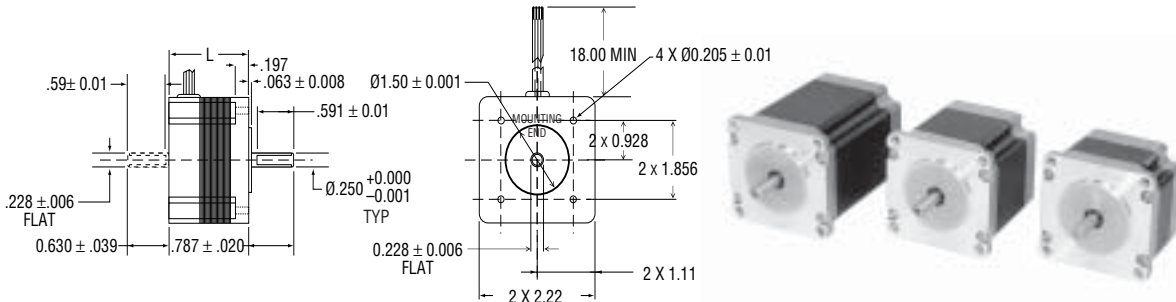

Part #	MOTOR CONNECTION 1 = series 2 = parallel 3 = unipolar	Motor Length (inches)	Minimum Holding Torque (oz-in)	Leads	Step Angle	Volts	Amps	Ohms	mH	Rotor Inertia (oz-in ² /G-CM ²)	Motor Weight (Lbs.)
HT23-398	1	2.13	177.0	8	1.8	3.3	2.12	1.5	4.8	1.64/300	1.54
	2	↓	177.0	↓	↓	1.6	4.24	0.4	1.2	↓	↓
	3	▽	125.0	↓	↓	2.3	3.00	0.8	1.2	▽	▽
HT23-399	1	2.99	264.0	↓	↓	11.6	0.71	16.4	56.0	2.62/480	2.20
	2	↓	264.0	↓	↓	5.8	1.41	4.1	14.0	↓	↓
	3	↓	187.0	↓	↓	8.2	1.00	8.2	14.0	↓	↓
HT23-400	1	↓	264.0	↓	↓	6.4	1.41	4.5	14.4	↓	↓
	2	↓	264.0	↓	↓	3.2	2.83	1.1	3.6	↓	↓
	3	↓	187.0	↓	↓	4.5	2.00	2.3	3.6	↓	↓
HT23-401	1	↓	264.0	↓	↓	4.2	2.12	2.0	6.4	↓	↓
	2	↓	264.0	↓	↓	2.1	4.24	0.5	1.6	↓	↓
	3	▽	187.0	▽	▽	3.0	3.00	1.0	1.6	▽	▽

OTHER LENGTHS AND WINDINGS AVAILABLE UPON REQUEST

- Part numbers listed are for single shaft. To order double shaft add 'D' to the end.
- All HT23 motors are optimized for microstepping.

Hybrid Step Motors
 SIZE HT23



Size HT23 Motor

Typical Speed/Torque Performance*

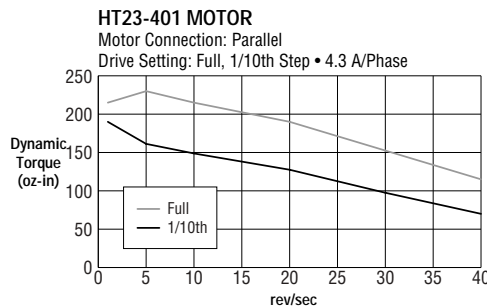
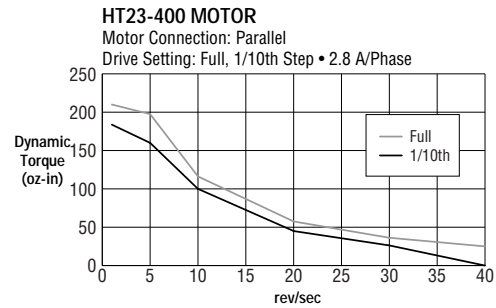
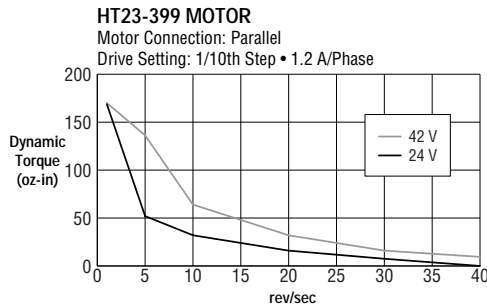
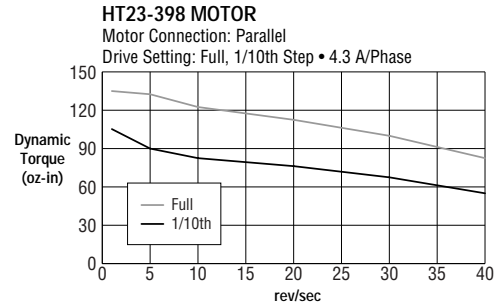
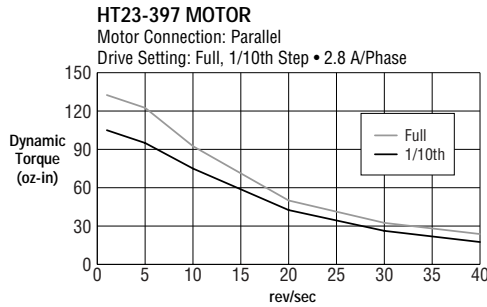
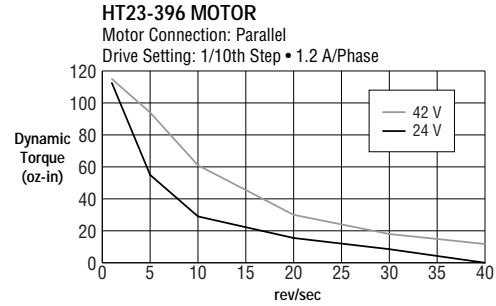
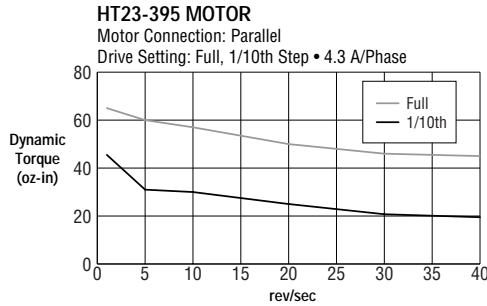
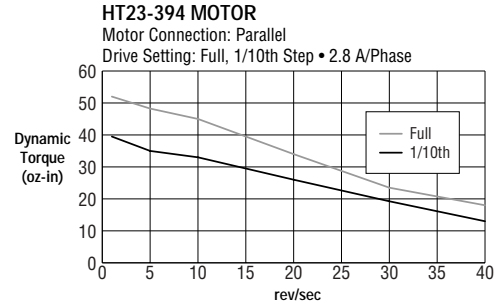
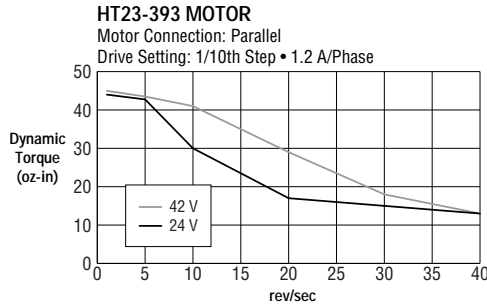

*Full steps/sec = Rev/sec x 200. Half steps/sec = Rev/sec x 400.